

BEACON/MORRIS GAS FIRED BLOWER UNIT HEATER



BGBS-7

DESCRIPTION

The Beacon/Morris Blower type unit heaters are ideal for commercial and institutional applications where a lower noise level is desired. Sterling's blower type unit heaters which operate at static pressures up to .2" W.C are extremely quiet.

Blower type unit heaters should be selected for applications where ductwork or discharge nozzles are to be used.

80% THERMAL EFFICIENCY

The designs are certified by CSA International as providing a minimum of 80% thermal efficiency. Approved for use in California, when equipped with Indirect Spark Ignition.

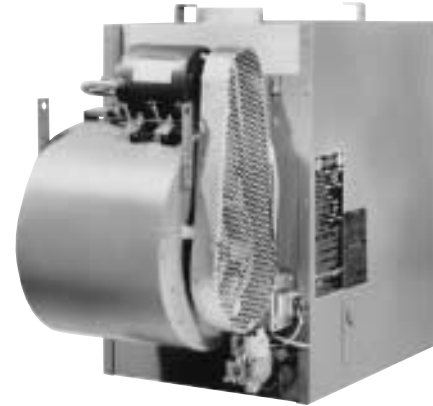

STANDARD FEATURES

- Fan Time Delay Switch - Under direct control of thermostat.
- 20 ga. Aluminized Steel Heat Exchanger.
- Supplied with 115/1/60 motor with overload protection.
- High Limit Switch.
- 24 Volt Combination Valve with Manual Shutoff.
- Transformer, 115/24.
- Horizontal individually adjustable louvers.
- Certified for Natural and Propane Gases.
- Burners - aluminized steel with stainless "Burner Shade Port Protector"
- 100% shut off Main and Pilot Gas.
- Units are factory tested for operation of motor, control, and flame.
- 20 ga. Steel Cabinet with Gray Enamel Finish.
- Belt Guard.
- Blocked Vent Safety Switch.

OPTIONAL EXTRAS

OPT. NO.	DESCRIPTION
—	Stainless Steel Heat Exchanger (409 or 321 S.S.)
—	Totally Enclosed Motors
S2	409 Stainless Steel Draft Diverters
S1	409 Stainless Steel Burners
Q6	Vertical Louvers
P6	Summer - Winter Toggle Switch
—	Mech. Mod. Gas Valve 60°-100° F.
—	Mech. Mod. Gas Valve 75°-200° F.
—	2-stage Valve 24 Volt.
G5	Room 2-Stage Honeywell Thermostat T874F-1007 with Q674C-1009 Sub Base
—	Indirect Spark Ignition System - NAT GAS- Installed At Factory,24 Volt.
—	Indirect Spark Ignition System - LP GAS 100% SHUT-OFF - Installed At Factory
A7	Pressure Regulator to Reduce Line Pressure to 14 inches W.C. Consult Customer Service for field requirements.
G3	Low voltage room thermostat with integral Switch for summer fan operation with the Sterling logo.
Q1	Y-Splitter Discharge Nozzle
Q2, Q3, Q4	30°, 60°, & 90° Downward Discharge Nozzle



260 North Elm Street • Westfield, MA 01085
Tel: (413) 562-5423 Fax: (413) 572-3764
www.beacon-morris.com

PROJECT: _____

UNIT TAG: _____



BMB – PERFORMANCE AND DIMENSIONAL DATA

Model BMB Unit Size	100	125	150	175	200	225	250	300	350	400
PERFORMANCE DATA †										
Input BTU/Hr	100,000	125,000	150,000	175,000	200,000	225,000	250,000	300,000	350,000	400,000
(kW)	(29.3)	(36.6)	(43.9)	(51.2)	(58.6)	(65.9)	(73.2)	(87.8)	(102.5)	(117.1)
Output BTU/Hr	80,000	100,000	120,000	140,000	160,000	180,000	200,000	240,000	280,000	320,000
(kW)	(23.4)	(29.3)	(35.1)	(41.0)	(46.9)	(52.7)	(58.6)	(70.3)	(82.0)	(93.7)
Thermal Efficiency (%)	80	80	80	80	80	80	80	80	80	80
Free Air Delivery CFM	1,200	1,575	1,975	2,300	2,400	2,600	2,850	3,950	4,600	4,800
(cu. m/s)	(0.566)	(0.743)	(0.932)	(1.086)	(1.133)	(1.227)	(1.345)	(1.864)	(2.171)	(2.266)
Air Temperature Rise Deg. F	62	59	56	56	62	64	65	56	56	62
(Deg. C)	(34)	(33)	(31)	(31)	(34)	(36)	(36)	(31)	(31)	(34)
Outlet Velocity FPM	880	950	1030	1045	965	935	930	1080	1090	1000
(m/s)	(4.47)	(4.83)	(5.23)	(5.31)	(4.90)	(4.75)	(4.72)	(5.49)	(5.54)	(5.08)
Full Load Amps at 115V ***	5.9	7.4	8.2	8.2	12.8	12.8	12.8	12.8	16.2	16.2
MOTOR DATA : Motor HP										
	1/4	1/3	1/2	1/2	3/4	3/4	3/4	3/4	1	1
Motor (kW)	(0.19)	(0.25)	(0.37)	(0.37)	(0.56)	(0.56)	(0.56)	(0.56)	(0.75)	(0.75)
Motor Type	SPH	SPH	SPH	SPH	SPH	SPH	SPH	SPH	cap.start	cap.start
R.P.M.	1725	1725	1725	1725	1725	1725	1725	1725	1725	1725
Amps @ 115V	5.1	6.6	7.4	7.4	12.0	12.0	12.0	12.0	15.4	15.4
DIMENSIONAL DATA in. (mm)										
"A" Height to Top of Unit	31-1/4 (794)	31-1/4 (794)	36-1/4 (921)	36-1/4 (921)	36-1/4 (921)	36-1/4 (921)	36-1/4 (921)	36-1/4 (921)	36-1/4 (921)	36-1/4 (921)
"B" Width of Unit	17-7/8 (454)	20-5/8 (524)	20-5/8 (524)	23-3/8 (594)	26-1/8 (664)	28-7/8 (733)	31-5/8 (803)	37-1/8 (943)	42-5/8 (1083)	48-1/8 (1222)
"C" Height to Top of Hanger	33-1/4 (845)	33-1/4 (845)	38-1/4 (972)	38-1/4 (972)	38-1/4 (972)	38-1/4 (972)	38-1/4 (972)	38-1/4 (972)	38-1/4 (972)	38-1/4 (972)
"D" Depth to Rear of Housing	42-5/8 (1083)	44-1/4 (1124)	44-1/4 (1124)	47 (1194)	47 (1194)	51 (1295)	51 (1295)	48-1/4 (1226)	51 (1295)	51 (1295)
"E" Hanging Distance Width	14-3/4 (375)	17-1/2 (444)	17-1/2 (444)	20-1/4 (514)	23- (584)	25-1/2 (648)	28-1/4 (718)	33-3/4 (857)	39-1/4 (997)	44-3/4 (1137)
"F" Discharge Opening Width	15-3/8 (391)	18-1/8 (460)	18-1/8 (460)	20-7/8 (530)	23-5/8 (600)	26-3/8 (670)	29-1/8 (740)	34-5/8 (879)	40-1/8 (1019)	45-5/8 (1159)
"L" Hanger Location	15-1/8 (384)	15-1/8 (384)	15-1/8 (384)	15-1/8 (384)	15-1/8 (384)	16-1/4 (413)	16-1/4 (413)	16-1/4 (413)	16-1/4 (413)	16-1/4 (413)
M" Hanging Distance Depth	24-5/8 (625)	25-7/8 (657)	17-1/2 (444)	19 (483)	19 (483)	21-7/8 (556)	21-7/8 (556)	27-7/8 (708)	28-7/8 (733)	28-7/8 (733)
"S" Flue Size Dia.-in.** (Dia-mm)	6 (152)	6 (152)	7 (178)	7 (178)	8 (203)	8 (203)	8 (203)	10 (254)	10 (254)	12 (305)
Flue Type **	R,V	R,V	R,H	R,H	R,H	R,H	R,H	OV,H	OV,H	OV▲
Blower Size-in.	9	10	10	12	12	12	12	10	12	12
Gas Inlet-Natural Gas-in.	1/2	1/2	1/2	1/2	1/2	3/4	3/4	3/4	3/4	3/4
Gas Inlet-LP Gas -in.	1/2	1/2	1/2	1/2	1/2	← 1/2 OR 3/4 →				
Approx. Shipping Wt. lb. (kg)	253 (115)	270 (122)	315 (143)	335 (152)	351 (159)	396 (180)	415 (188)	459 (208)	550 (249)	582 (264)

▲ See Special Details for BMB-400 Venting. **R = Round; OV = Oval; H = Horizontal; V = Vertical ***These amps are based on standing pilot units.
† Ratings shown are for unit installations at elevations between 0 and 2000 ft. (610m). For unit installations in USA above 2000 ft. (610m), the unit input must be derated 4% for each 1000 ft. (305m) above sea level; refer to local codes, or in absence of local codes, refer to the National Fuel Gas Code, ANSI Standard Z223.1-1999 (N.F.P.A. No. 54), or the latest edition of.
For installations in Canada, any references to deration at altitudes in excess of 2000 ft. (610m) are to be ignored. At altitudes of 2000 to 4500 ft. (610 to 1372m), the unit must be derated to 90% of the normal altitude rating, and be so marked in accordance with the CSA certification.

LEGEND: SPH = Split Phase CAP. START = Capacitor Start

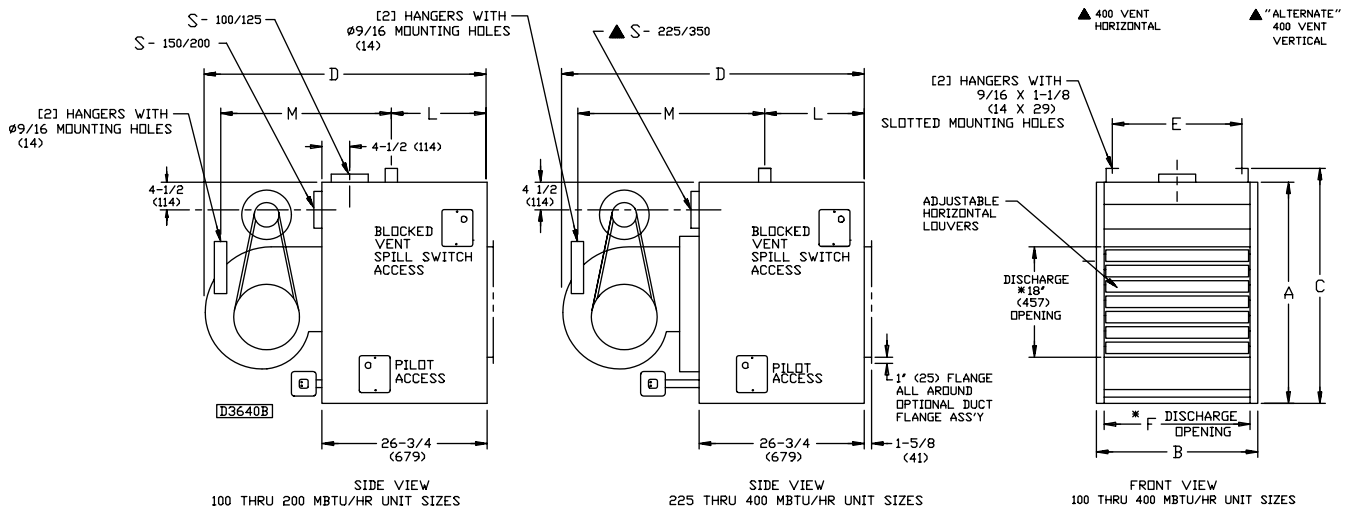
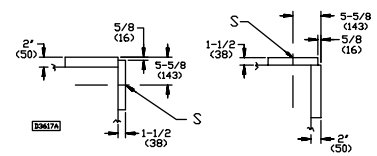

DIMENSIONS .XXX STANDARD UNITS
DIMENSIONS IN PARENTHESIS (XXX) MILLIMETERS

*DISCHARGE OPENING FOR OPTIONAL "DUCT FLANGE ASSY"