

CABINET UNIT HEATER SUBMITTAL DATA

CBS-FS-15RM

Slope Top Floor Mounted Units - Models FS and FSI - Metric

PIPING AND MOUNTING CONNECTIONS SHOWN ARE TYPICAL FOR ALL AIR FLOW ARRANGEMENTS SEE OTHER SIDE.

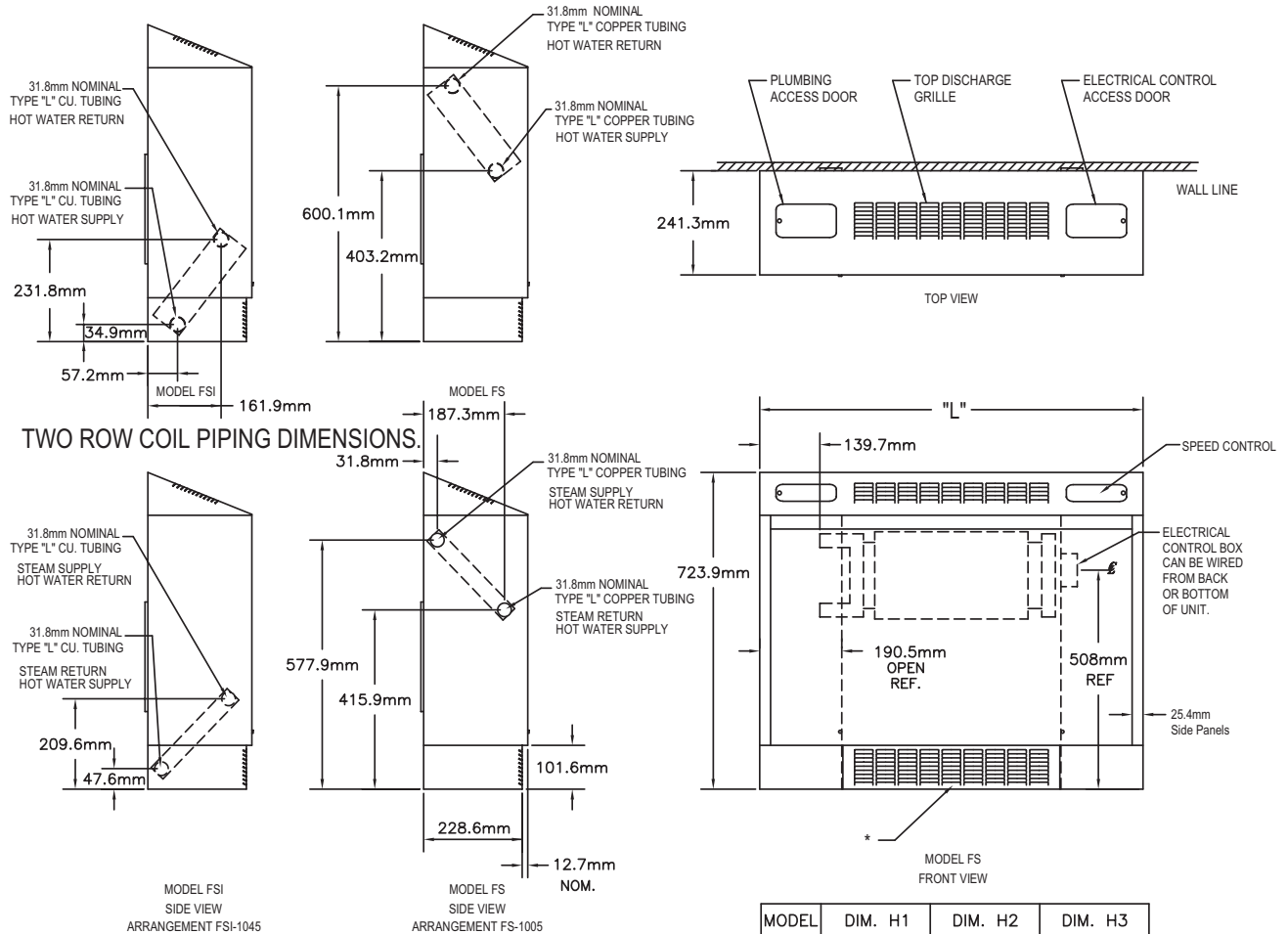

STANDARD ONE ROW COIL PIPING DIMENSIONS.

MODEL	DIM. H1	DIM. H2	DIM. H3
FS	231.8mm	308.0mm	384.2mm
FSI	241.3mm	317.5mm	393.7mm

SIZE	DIM "A"	DIM "L"
02	155.6mm	889.0mm
03	155.6mm	1092.2mm
04	155.6mm	1193.8mm
06	269.9mm	1498.6mm
08	269.9mm	1549.4mm
10	269.9mm	1676.4mm
12	422.3mm	1854.2mm
14	422.3mm	2159.0mm

* LOUVERED INLET GRILLE IS STANDARD ON "FSI" MODELS
 OPTIONAL ON "FS" MODELS
 SEE OPTION 17

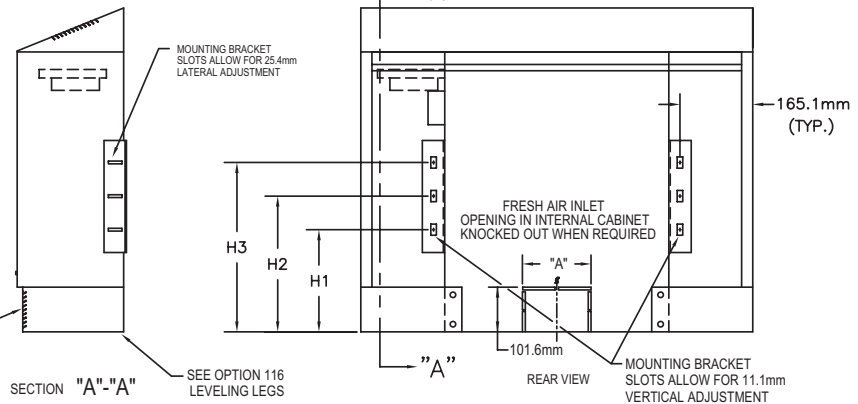

PROJECT: _____
LOCATION: _____
ARCHITECT: _____
ENGINEER: _____
CONTRACTOR: _____
PO NUMBER: _____
DATE: _____

CAT00211B



260 North Elm St. • Westfield, MA 01085
 Tel: (413) 568-9571 • Fax (413) 564-5661
 www.vulcanrad.com



CABINET UNIT HEATERS RATINGS AND SPECIFICATIONS

ENTERING WATER - 93.3°C
ENTERING AIR - 15.5°C

TABLE I - METRIC







UNIT SIZE		02	03	04	06	08	10	12	14
HEATING CAP. - HOT WATER	WATTS	4806.4	6682.0	8733.5	14067.4	15972.4	18170.4	22156.2	23006.1
	LITER/SECOND	0.10	0.14	0.19	0.30	0.34	0.39	0.48	0.50
HIGH CAP. - COIL 2 ROW									
HEATING CAP HOT WATER	WATTS	7561.2	10374.7	13569.2	20456.4	25673.0	29834.6	35109.9	37688.9
	LITER/SECOND	0.16	0.22	0.29	0.44	0.55	0.64	0.76	0.81
SEE TABLE III FOR WTD									
HIGH CAP. - STEAM									
2 PSIG STANDARD	WATTS	6623.4	9202.4	12015.9	19372.0	22009.6	25028.3	30508.7	31710.3
	EDR	94	131	171	275	313	356	434	451
COIL:	COND. KG/HR	10.6	14.7	19.3	31.0	35.3	40.1	48.9	50.8
	NUMBER FINS PER CM	31	31	31	31	31	31	31	31
	FACE AREA-M ²	0.09	0.14	0.17	0.24	0.26	0.29	0.33	0.41
	COIL CONNECTIONS	31.75mm	31.75mm	31.75mm	31.75mm	31.75mm	31.75mm	31.75mm	31.75mm
BLOWERS:									
	NUMBER	1	1	2	2	3	3	4	4
STANDARD PSC MOTOR:	HP	1/15	1/15	1/10	1/10	1 @ 1/10 1 @ 1/15	1 @ 1/10 1 @ 1/15	1/10	1/10
	RPM:	HIGH	1050	1050	1050	1050	1050	1050	1050
	LOW	875	875	875	875	875	875	875	
	NUMBER	1	1	1	1	2	2	2	
	VOLTS/PHASE/HERTZ	115/1/60	115/1/60	115/1/60	115/1/60	115/1/60	115/1/60	115/1/60	
	AMPERES	0.8	0.8	1.4	1.4	2.2	2.2	2.8	
FAN SPEED CONTROL	STANDARD MTR	VAR.	VAR.	VAR.	VAR.	VAR.	VAR.	VAR.	
CFM:	HIGH	230	335	430	630	860	1060	1230	
	LOW	185	270	345	505	685	845	985	
OPTIONAL ECM MOTOR:	HP	1/15	1/15	1/15	1/15	1/10	1/10	1/4	
	NUMBER	1	1	1	1	2	2	2	
	VOLTS/PHASE/HERTZ	120/1/60	120/1/60	120/1/60	120/1/60	120/1/60	120/1/60	120/1/60	
	AMPERES	0.45	0.45	0.65	0.85	1.5	1.95	2.8	
FAN SPEED CONTROL	ECM MTR	3 - SPEED	3 - SPEED	3 - SPEED	3 - SPEED	3 - SPEED	3 - SPEED	3 - SPEED	
CFM:	HIGH	230	335	430	630	860	1060	1230	
	MED	160	240	375	440	590	740	850	
	LOW	120	150	280	320	450	560	640	
FILTERS:	NO.	1	1	1	1	1	1	1	
	TYPE	PERM.	PERM.	PERM.	PERM.	PERM.	PERM.	PERM.	
	LENGTH (mm)	501.65	704.85	806.45	1111.25	1162.05	1289.05	1466.85	
	WIDTH (mm)	220.66	220.66	220.66	220.66	220.66	220.66	220.66	
	THICKNESS (mm)	12.70	12.70	12.70	12.70	12.70	12.70	12.70	
dB LEVEL 457 (mm) FROM UNIT		50	52	53	54	55	55	56	
	LENGTH (mm)	889	1092.2	1193.8	1498.6	1549.4	1676.4	1854.2	
	HEIGHT (mm)	635	635	635	635	635	635	635	
	DEPTH (mm)	241.3	241.3	241.3	241.3	241.3	241.3	241.3	

Note: On FS and FSI units use 724 mm on all heights

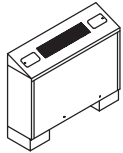
FILTER IDENTIFICATION AND DATA		
SIZE	PART NO.	FILTER SIZE
02	PC1297-2	11.9mm x 220.7mm x 507.7mm
03	PC1297-3	11.9mm x 220.7mm x 704.9mm
04	PC1297-4	11.9mm x 220.7mm x 806.5mm
06	PC1297-6	11.9mm x 220.7mm x 1111.3mm
08	PC1297-8	11.9mm x 220.7mm x 1162.1mm
10	PC1297-10	11.9mm x 220.7mm x 1289.1mm
12	PC1297-12	11.9mm x 220.7mm x 1466.9mm
14	PC1297-14	11.9mm x 220.7mm x 1771.7mm

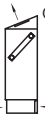
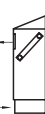
CABINET UNIT HEATERS SHIPPING WEIGHT (KG)

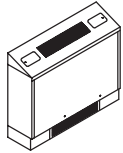
STYLE	SIZE							
	02	03	04	06	08	10	12	14
FS-FSI	42.64	50.35	56.25	68.04	76.20	80.74	89.81	101.15

SLOPE TOP FLOOR	FS		 FS-1005	 FS-1015 25% F.A.	 FS-1025 ← See options 18 & 19 →	 FS-1035 25% F.A.	OPTION <input type="checkbox"/> 18 <input type="checkbox"/> 19	
SLOPE TOP FLOOR INVERTED FLOW	FSI		 FSI-1045	 FSI-1055				

SPECIFICATIONS & WARRANTY*

*STANDARD CABINET UNIT ONLY

The contractor shall furnish and install Vulcan Cabinet Unit Heaters as selected to meet or exceed job requirements. The Cabinet Unit Heaters will conform to the items listed below and be certified under CSA guidelines.

CABINETS

All cabinets will be constructed with 18-gauge cold rolled steel, side panels and top. The front panel shall be furnished in 16-gauge cold rolled steel. It will have 1/2", 1-1/2 pound insulation with one side neoprene coated in front of coil. The internal cabinet shall be furnished in 18-gauge galvanized steel. Adequate work area for installation of control valves or electrical equipment shall be provided on both sides of the internal cabinet.

The cabinet shall be provided with a neutral eggshell baked enamel prime coat as standard. (Available if specified) Powder coated baked enamel, color selected from standard.

All cabinets shall be supplied with adjustable rear mounting brackets which will provide adjustment to correct alignment of the unit at installation to non square or out of true walls, joists, studs or surfaces. Adjustable leveling legs (two each base leg) are available when specified.

RECESSED UNITS

All recessed units shall be supplied with a "Wall Seal" assembly. This assembly shall provide protection to the wall or ceiling construction material. The "Wall Seal" shall be supplied in an eggshell baked enamel prime coat as standard. (When specified) Baked enamel colors may be selected from standard.

CEILING MOUNT OR RECESSED UNITS

All "C" and "RC" units shall be supplied with a hinged front panel. The multiple hinges shall provide full swing through 90°. A safety chain shall be provided as standard to prevent the face panel from swinging fully open accidentally. This chain must be easily detached to allow full access for servicing. Speed control switch will be shipped with wiring diagram for installation where desired.

FILTERS

All filters supplied as standard shall be reusable aluminum media with a 69% arrestance level. Filters shall be slide in type which are locked into position with a cotter pin.

FANS

Fan wheels shall be centrifugal, forward curved, double width. Fan housings shall be of formed galvanized sheet metal.

COILS

STANDARD ONE ROW - The durable mechanically bonded copper/aluminum coil presents the best of today's hydronic heating technology. All element assemblies are submersion tested at factory at 250 PSI and are rated at a working pressure of 300 PSI. All units are designed so that field modifications can be made to reverse the coil position if required.

HIGH CAPACITY COIL - This is a hot water coil designed to provide increased capacity when the required load exceeds that of the standard coil for a given size. Its construction is similar to the standard coil however, there are two rows of tubes. Element assemblies are submersion tested at 250 PSI and are rated at a working pressure of 300 PSI.

MOTORS

Standard PSC motors shall have integral thermal protection and start at 78% of rated voltage. Optional PSC High Static motors will be capable of operating in high static conditions up to .4 inches of water column. All motors shall be factory run-tested and assembled in unit prior to shipping. Optional ECM and high static motors will have a solid state control board and a 3 speed switch. All motors shall be factory run-tested and assembled in unit prior to shipping.

ELECTRICAL

All primary internal wiring shall be done at the factory and every unit shall be factory tested for reliability.

FRESH AIR DAMPERS ON DESIGANTED UNITS ONLY

When desired specify either of the following:

1. Where noted 25% Manual Outside Air Dampers shall be provided. A manually operated damper quadrant shall provide from 0% to 25% outside air through the use of a single blade damper.

2. Where noted 25% Motorized Outside Air Dampers shall be provided. A synchronous motor (115/60/1) interlocked with the blower shall automatically open the outside air damper when blower starts. The single blade damper shall be adjustable from 0% to 25% outside air. When the blower stops or there is a loss of power, the damper shall return to the closed position. A damper override switch shall be provided to prevent damper operation when desired.

WARRANTY

The products in this catalog are warranted by Vulcan, to be free from defects in material and workmanship for a period of one (1) year from the date of shipment from Vulcan's plant. Vulcan's liability under this warranty is limited to replacing or repairing at our option, F.O.B. our plant any defective component or assembly returned to our factory prepaid and with proper return authorization document. All repairs or replacements are made subject to factory inspection. In the interest of product improvement, Vulcan reserves the right to make changes without notification.



260 North Elm St. • Westfield, MA 01085
Tel: (413) 568-9571 • Fax (413) 564-5661
www.vulcanrad.com

