

TURBO-PAK

Submittal

Style "TP"
Slope Top Enclosures
Copper/Aluminum &
Steel Element Ratings

Specification

ENCLOSURE:

STYLE : "TP"
OUTLET: Slope Louvered
Two-Piece
LENGTHS: 3' thru 8' in 1' Increments
MATERIAL 18 Ga. C.R.S. Std.
FINISH: Baked Powder

BACKPLATE:

TYPE: Partial Backplate
MATERIAL: 20 Ga. Painted Std.

Note: Assembly includes all necessary components for complete installation less accessories.
Element is shipped in separate carton.

ELEMENT:

TYPE: Cu/Al (Mechanically Expanded)
LENGTHS: 2' thru 8' in 1' Increments.
One End Flared, Std.
See Catalog for Working Pressures.

ELEMENT:

TYPE: Steel (Mechanically Expanded)
LENGTHS: 2' thru 8' in 1' Increments.
 NPT Threads Both Ends (standard)
 Beveled Ends for Field Weld

ACCESSORIES:

All overlapping, engage between backplate and wall at top. Bottom returns to wall, holes provided for fasteners.

BRACKETS: Bracket w/Brkt Mtd B.B. Hanger

STEEL

ELEMENT DESIGNATION	NOMINAL PIPE SIZE	CRADLE	A MINIMUM	A MAXIMUM
S143-032	1-1/4" (32)	2	7-7/8" (200)	8-15/16" (227)
S243-032	2" (50)	1	7-5/8" (194)	8-3/4" (222)

COPPER

ELEMENT DESIGNATION	NOMINAL PIPE SIZE	CRADLE	A MINIMUM	A MAXIMUM
C3/4-435	3/4" (20)	2	7-3/8" (187)	8-1/2" (216)
C435	1" (25)	2	7-1/2" (191)	8-5/8" (219)
C1435	1-1/4" (32)	2	7-5/8" (194)	8-13/16" (224)

TP-14

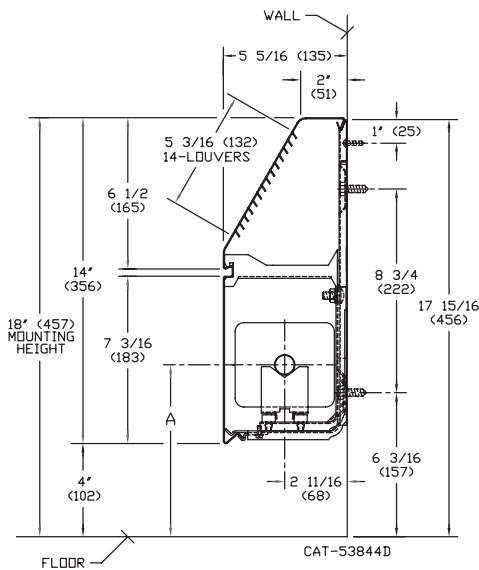

Note: Dimensions in "()" are shown in millimeters.

TP-20

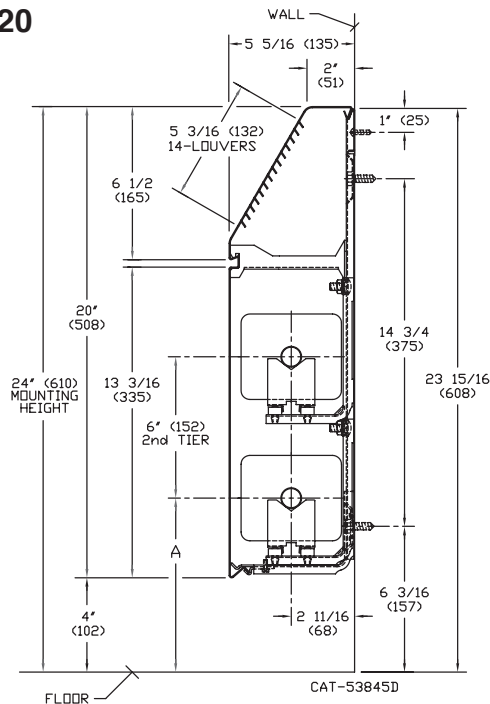

260 North Elm Street • Westfield, MA 01085
Tel: (800) 762-5005 • Fax: (413) 572-3764
www.turbonicsinc.com

A MESTEK COMPANY



PROJECT: _____ DATE: _____

LOCATION: _____

ARCHITECT: _____

ENGINEER: _____

CONTRACTOR: _____

PO NUMBER: _____

STYLE "TP"

COPPER/ALUMINUM ELEMENT RATINGS

ALL RATINGS ARE BASED ON 3 FPS VELOCITY, 65° EAT

TUBE SIZE	CATALOG DESIGNATION	FIN SIZE HEIGHT X WIDTH	FINS PER FT.	FIN THICKNESS IN INCHES	ENCL DEPTH AND HEIGHT IN INCHES	TIERS AND CENTERS IN INCHES	MOUNTING HEIGHT IN INCHES	STEAM 215° FACTOR	HOT WATER (AVG.)					
									200°	190°	180°	170°	160°	150°
									CORRECTION FACTORS					
								1.00	0.86	0.78	0.69	0.61	0.53	0.45
3/4"	C3/4-435	3-5/8" x 4-1/4"	50	.020	14B	1	18	1840	1580	1440	1270	1120	980	830
					20B	1	24	2090	1800	1630	1440	1270	1110	940
					20B	2-6 CL	24	2820	2430	2200	1950	1720	1490	1270
1"	C435	3-5/8" x 4-1/4"	50	.020	14B	1	18	1930	1660	1510	1330	1180	1020	870
					20B	1	24	2180	1870	1700	1500	1330	1160	980
					20B	2-6 CL	24	2640	2270	2060	1820	1610	1400	1190
1-1/4"	C1435	3-5/8" x 4-1/4"	50	.020	14B	1	18	1860	1600	1450	1280	1130	990	840
					20B	1	24	2130	1830	1660	1470	1300	1130	960
					20B	2-6 CL	24	2510	2160	1960	1730	1530	1330	1130

STEEL ELEMENT RATINGS

ALL RATINGS ARE BASED ON 3 FPS VELOCITY, 65° EAT

TUBE SIZE	CATALOG DESIGNATION	FIN SIZE HEIGHT X WIDTH	FINS PER FT.	FIN THICKNESS IN INCHES	ENCL DEPTH AND HEIGHT IN INCHES	TIERS AND CENTERS IN INCHES	MOUNTING HEIGHT IN INCHES	STEAM 215° FACTOR	HOT WATER (AVG.)					
									200°	190°	180°	170°	160°	150°
									CORRECTION FACTORS					
								1.00	0.86	0.78	0.69	0.61	0.53	0.45
1-1/4"	S144-032	4-1/4" SQ.	40	.032	14B	1	18	1570	1350	1220	1080	960	830	710
					20B	1	24	1670	1440	1300	1150	1020	890	750
					20B	2-6 CL	24	2370	2040	1850	1640	1450	1260	1070
2"	S243-032	4-1/4" SQ.	32	.032	14B	1	18	1400	1200	1090	970	850	740	630
					20B	1	24	1450	1250	1130	1000	880	770	650
					20B	2-6 CL	24	2110	1810	1650	1460	1290	1120	950

Guaranteed Working Pressures (PSI)

1-1/4" IPS: 660 @ temps. up to 650°F

2" IPS: 405 @ temps. up to 650°F

1-1/4" CU: 194 @ temps. up to 300°F

1" CU: 204 @ temps. up to 300°F

3/4" CU: 218 @ temps. up to 300°F

Maximum pressures at other temperatures are available upon request.

Installation Details

- Standard length: Available from 3' to 8' in 12" increments.
- When two or more enclosures occur in a run, a 4" wall sleeve is to be used at joints.

