

JVB Slip Jointed Enclosure

Specification

ENCLOSURE:

- STYLE: Slope Top, Slope Outlet
 OUTLET: Extruded Aluminum Grille
 Pencil Proof
 LENGTHS: 2'0" thru 8'0" in 6" Increments
 MAT'L: 16 Ga. CRS (Std)
 14 Ga. CRS (Opt'l)
 16 Ga. Stainless Steel (Opt'l)
 14 Ga. Stainless Steel (Opt'l)
 14 Ga. Aluminum (Opt'l)
 12 Ga. Aluminum (Opt'l)
 HEIGHT: 14"
 20"
 24"
 30"
 36"
 FINISH: Baked Powder (Std)
 Baked Metallic (Opt'l)

ACCESSORIES:

JV Overlapping Type
 All accessories return to the wall at the bottom and have pre-punched holes for fastening to the wall.

ELEMENT:

- TYPE: Cu/Al (Mechanically Expanded)
 LENGTHS: 2'0" thru 8'0" in 1" Increments for 1" & 1-1/4" Cu.
 2'0" thru 8'0" in 1" Increments for 3/4" Cu.
 One End Flared (Std)
 See Catalog for Working Pressures

DAMPER:

Not Available

BACKPLATE:

- TYPE: Partial B/P
 LENGTHS: 8'0" Only
 MAT'L: 20 Ga. Prepainted (Std)
 18 Ga. Galvannealed (Opt'l)
 TYPE: Full Ht. B/P (Opt'l)
 LENGTHS: 2'0" thru 8'0" in 6" Increments
 MAT'L: 20 Ga. Galvannealed (Opt'l)
 20 Ga. Painted (Opt'l)
 18 Ga. Painted (Opt'l)

AIRSEAL:

- 1/8" x 3/8" Closed Cell (Opt'l)

BRACKETS:

- Water Brkt (with Stand-Off)
 Stand-Off not required with 14", 20", & 24"
 B.B. Hanger, Bracket Mtd
 B. B. Hanger, Wall Mtd
 Wall Mtd B.B. Hanger required for 3rd Tier Element

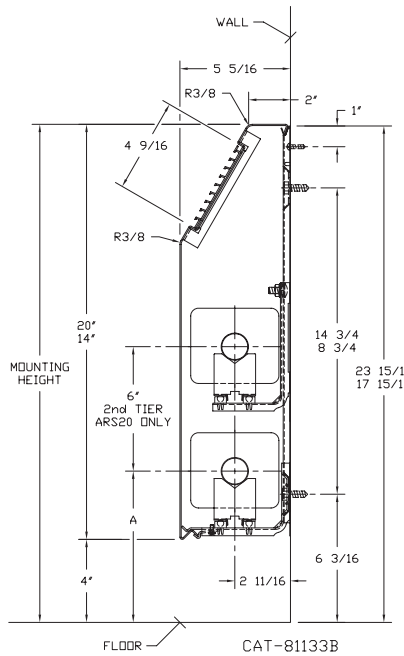

ELEMENT TUBE SIZE	ELEMENT FIN SIZE HEIGHT x WIDTH	CRADLE	A
3/4" COPPER	3 5/8 x 4 1/4	2	7"
3/4" COPPER	4 1/4 x 4 1/4	3A	7 3/8

- JVB-ARS 14**
 JVB-ARS 20

- JVB-ARS 24**
 JVB-ARS 30
 JVB-ARS 36

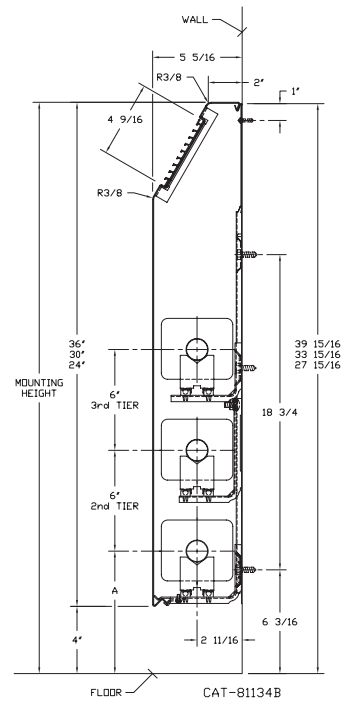

260 North Elm St., Westfield, MA 01085
 (413) 564-5535 Fax: (413) 562-8437
 www.sterlingheat.com

PROJECT: _____ DATE: _____
 LOCATION: _____
 ARCHITECT: _____
 ENGINEER: _____
 CONTRACTOR: _____
 PO NUMBER: _____



JVB-ARS

Copper/Aluminum Elements

ALL RATINGS ARE BASED ON 3 FPS WATER VELOCITY, 65°EAT

TUBE SIZE	CATALOG DESIGNATION	FIN SIZE HEIGHT X WIDTH	FIN PER FT.	FIN THICKNESS IN INCHES	ENCL DEPTH AND HEIGHT IN INCHES	TIERS AND CENTERS IN INCHES	MTG. HEIGHT IN INCHES	STEAM 215°F FACTOR	HOT WATER (AVG.)																	
									200°F	190°F	180°F	170°F	160°F	150°F	140°F	130°F	120°F	110°F	100°F							
									CORRECTION FACTORS FOR AVERAGE WATER TEMPERATURES																	
								1.00	0.86	0.78	0.69	0.61	0.53	0.45	.40	.33	.26	.20	.15							
3/4"	C3/4-433	3-5/8" x 4-1/4"	32	.020	14B	1	18	1520	1310	1190	1050	930	810	680	610	500	400	300	230							
					20B	1	24	1600	1380	1250	1100	980	850	720	640	530	420	320	240							
					20B	2-6 CL	24	2480	2130	1930	1710	1510	1310	1120	990	820	640	500	370							
					24B	1	28	1670	1440	1300	1150	1020	890	750	670	550	430	330	250							
					24B	2-6 CL	28	2570	2210	2000	1770	1570	1360	1160	1030	850	670	510	390							
					24B	3-6 CL	28	2960	2550	2310	2040	1810	1570	1330	1180	980	770	590	440							
					30B	1	34	1750	1510	1370	1210	1070	930	790	700	580	460	350	260							
					30B	2-6 CL	34	2680	2300	2090	1850	1630	1420	1210	1070	880	700	540	400							
					30B	3-6 CL	34	3080	2650	2400	2130	1880	1630	1390	1230	1020	800	620	460							
					36B	1	40	1830	1570	1430	1260	1120	970	820	730	600	480	370	270							
					36B	2-6 CL	40	2790	2400	2180	1930	1700	1480	1260	1120	920	730	560	420							
					36B	3-6 CL	40	3210	2760	2500	2210	1960	1700	1440	1280	1060	830	640	480							
3/4"	C3/4-434	3-5/8" x 4-1/4"	40	.020	14B	1	18	1700	1460	1330	1170	1040	900	770	680	560	440	340	260							
					20B	1	24	1820	1570	1420	1260	1110	960	820	730	600	470	360	270							
					20B	2-6 CL	24	2580	2220	2010	1780	1570	1370	1160	1030	850	670	520	390							
					24B	1	28	1910	1640	1490	1320	1170	1010	860	760	630	500	380	290							
					24B	2-6 CL	28	2700	2320	2110	1860	1650	1430	1220	1080	890	700	540	410							
					24B	3-6 CL	28	3080	2650	2400	2130	1880	1630	1390	1230	1020	800	620	460							
					30B	1	34	2000	1720	1560	1380	1220	1060	900	800	660	520	400	300							
					30B	2-6 CL	34	2830	2430	2210	1950	1730	1500	1270	1130	930	740	570	420							
					30B	3-6 CL	34	3230	2780	2520	2230	1970	1710	1450	1290	1070	840	650	480							
					36B	1	40	2090	1800	1630	1440	1270	1110	940	840	690	540	420	310							
					36B	2-6 CL	40	2890	2490	2250	1990	1760	1530	1300	1160	950	750	580	430							
					36B	3-6 CL	40	3290	2830	2570	2270	2010	1740	1480	1320	1090	860	660	490							
3/4"	C3/4-435	3-5/8" x 4-1/4"	50	.020	14B	1	18	1840	1580	1440	1270	1120	980	830	740	610	480	370	280							
					20B	1	24	2090	1800	1630	1440	1270	1110	940	840	690	540	420	310							
					20B	2-6 CL	24	2820	2430	2200	1950	1720	1490	1270	1130	930	730	560	420							
					24B	1	28	2260	1940	1760	1560	1380	1200	1020	900	750	590	450	340							
					24B	2-6 CL	28	3110	2670	2430	2150	1900	1650	1400	1240	1030	810	620	470							
					24B	3-6 CL	28	3510	3020	2740	2420	2140	1860	1580	1400	1160	910	700	530							
					30B	1	34	2510	2160	1960	1730	1530	1330	1130	1000	830	650	500	380							
					30B	2-6 CL	34	3330	2860	2600	2300	2030	1760	1500	1330	1100	870	670	500							
					30B	3-6 CL	34	3760	3230	2930	2590	2290	1990	1690	1500	1240	980	750	560							
					36B	1	40	2760	2370	2150	1900	1680	1460	1240	1100	910	720	550	410							
					36B	2-6 CL	40	3580	3080	2790	2470	2180	1900	1610	1430	1180	930	720	540							
					36B	3-6 CL	40	4050	3480	3160	2790	2470	2150	1820	1620	1340	1050	810	610							
3/4"	C3/4-43	4-1/4" SQ.	32	.020	14B	1	18	1630	1400	1270	1120	990	860	730	650	540	420	330	240							
					20B	1	24	1720	1480	1340	1190	1050	910	770	690	570	450	340	260							
					20B	2-6 CL	24	2630	2260	2050	1810	1600	1390	1180	1050	870	680	530	390							
					24B	1	28	1790	1540	1400	1240	1090	950	810	720	590	470	360	270							
					24B	2-6 CL	28	2810	2420	2190	1940	1710	1490	1260	1120	930	730	560	420							
					24B	3-6 CL	28	3230	2780	2520	2230	1970	1710	1450	1290	1070	840	650	480							
					30B	1	34	1860	1600	1450	1280	1130	990	840	740	610	480	370	280							
					30B	2-6 CL	34	2920	2510	2280	2010	1780	1550	1310	1170	960	760	580	440							
					30B	3-6 CL	34	3360	2890	2620	2320	2050	1780	1510	1340	1110	870	670	500							
					36B	1	40	1930	1660	1510	1330	1180	1020	870	770	640	500	390	290							
					36B	2-6 CL	40	3030	2610	2360	2090	1850	1610	1360	1210	1000	790	610	450							
					36B	3-6 CL	40	3480	2990	2710	2400	2120	1840	1570	1390	1150	900	700	520							
3/4"	C3/4-44	4-1/4" SQ.	40	.020	14B	1	18	2030	1750	1580	1400	1240	1080	910	810	670	530	410	300							
					20B	1	24	2210	1900	1720	1520	1350	1170	990	880	730	570	440	330							
					20B	2-6 CL	24	2930	2520	2290	2020	1790	1550	1320	1170	970	760	590	440							
					24B	1	28	2350	2020	1830	1620	1430	1250	1060	940	780	610	470	350							
					24B	2-6 CL	28	3210	2760	2500	2210	1960	1700	1440	1280	1060	830	640	480							
					24B	3-6 CL	28	3660	3150	2850	2530	2230	1940	1650	1460	1210	950	730	550							
					30B	1	34	2520	2170	1970	1740	1540	1340	1130	1010	830	660	500	380							
					30B	2-6 CL	34	3450	2970	2690	2380	2100	1830	1550	1380	1140	900	690	520							
					30B	3-6 CL	34	3930	3380	3070	2710	2400	2080	1770	1570	1300	1020	790	590							
					36B	1	40	2700	2320	2110	1860	1650	1430	1220	1080	890	700	540	410							
					36B	2-6 CL	40	3610	3100	2820	2490	2200	1910	1620	1440	1190	940	720	540							
					36B	3-6 CL	40	4120	3540	3210	2840	2510	2180	1850	1650	1360	1070	820	620							
3/4"	C3/4-45	4-1/4" SQ.	50	.020	14B	1	18	2040	1750	1590	1410	1240	1080	920	820	670	530	410	310							
					20B	1	24	2320	2000	1810	1600	1420	1230	1040	930	770	600	460	350							
					20B	2-6 CL	24	3070	2640	2390	2120	1870	1630	1380	1230	1010	800	610	460							
					24B	1																				

Design Data

Correction Factor Chart for Non-Standard Mounting Heights

MOUNTING HEIGHT (Inches)	ENCLOSURE STYLE						
	BARE FIN ALL SIZES	FRONT OUTLET	FT (FRONT & TOP)		SLOPE		
			3 ¹ / ₄ " FINS	4 ¹ / ₄ " FINS	2 ³ / ₄ " FINS	3 ¹ / ₄ " FINS	4 ¹ / ₄ " FINS
40 or more	1.000	1.000	1.000	1.000	1.000	1.000	1.000
38	1.000	1.000	1.000	1.000	1.000	1.000	1.003
36	1.000	1.004	1.005	1.005	1.006	1.007	1.009
34	1.010	1.014	1.011	1.010	1.012	1.013	1.016
32	1.020	1.024	1.017	1.015	1.019	1.020	1.025
30	1.030	1.039	1.029	1.024	1.031	1.033	1.039
29	1.040	1.049	1.035	1.029	1.038	1.040	1.045
28	1.050	1.059	1.041	1.034	1.045	1.047	1.052
27	1.060	1.069	1.046	1.039	1.051	1.053	1.059
26	1.070	1.079	1.052	1.044	1.058	1.060	1.065
25	1.080	1.089	1.058	1.049	1.065	1.067	1.072
24	1.090	1.099	1.064	1.054	1.071	1.073	1.079
23	1.100	1.109	1.070	1.059	1.078	1.080	1.085
22	1.110	1.119	1.076	1.064	1.085	1.087	1.092
21	1.120	1.129	1.082	1.069	1.091	1.093	1.099
20	1.130	1.139	1.088	1.074	1.098	1.100	1.100
19	1.140	1.149	1.089	1.075	1.100	1.100	1.100
18 or less	1.150	1.150	1.089	1.075	1.100	1.100	1.100

TOP OUTLET "T" IS NOT AFFECTED.

The AHRI Ratings cataloged include the factor shown for the recommended mounting height.

If the unit is to be installed at a different height than that recommended, the AHRI Rating (except for Top Outlet) must be adjusted as follows: AHRI Rating multiplied by

Factor from Table Above
for actual mounting height

Factor from Table Above
for recommended mounting height

EXAMPLE: Corrected steam rating for
1 row C145 element in JVBF14 (14"
high enclosures) mounted 30" above
floor in lieu of the 18" recommended.

FORMULA:

Catalog Rating x $\frac{\text{Factor at 30" Height}}{\text{Factor at 18" Height}}$

SOLUTION: 1950 x $\frac{1.039}{1.150}$ = 1760 BTU/Hr.

DYNAMIC FORMULAS

BTU = GPM x 500 x TD

$$\text{GPM} = \left(\frac{\text{BTU}}{500} \right) \div \text{TD}$$

$$\text{TD} = \left(\frac{\text{BTU}}{500} \right) \div \text{GPM}$$

Design Data

COMMERCIAL FINNED TUBE RATING CORRECTION CHARTS

CATALOG FINNED TUBE RATINGS ARE BASED UPON THE FOLLOWING CONDITIONS:

- 215°F AVERAGE WATER OR STEAM TEMPERATURE
- 65°F ENTERING AIR TEMPERATURE
- 3 FEET PER SECOND WATER FLOW RATE
- CATALOG MOUNTING HEIGHT

USE THE FOLLOWING CALCULATION WITH CORRECTION FACTORS FOR JOB CONDITIONS TO DETERMINE CORRECTED RATING:

$$\text{CORRECTED RATING} = (\text{215°F CATALOG RATING}) \times \left(\frac{\text{CORRECTION FACTOR FOR STEAM OR WATER AND AVERAGE AIR TEMP.}}{\text{CORRECTION FACTOR FOR MOUNTING HTG. - SEE CATALOG RATING}} \right) \times \left(\frac{\text{CORRECTION FACTOR FOR FLOW RATE}}{\text{CORRECTION FACTOR FOR MOUNTING HTG. - SEE CATALOG RATING}} \right)$$

USE THE FOLLOWING CHARTS TO SELECT CORRECTION FACTORS

CHART/WATER VEL./CORR. FACTOR / PRESS. DROP/TOTAL BTU.

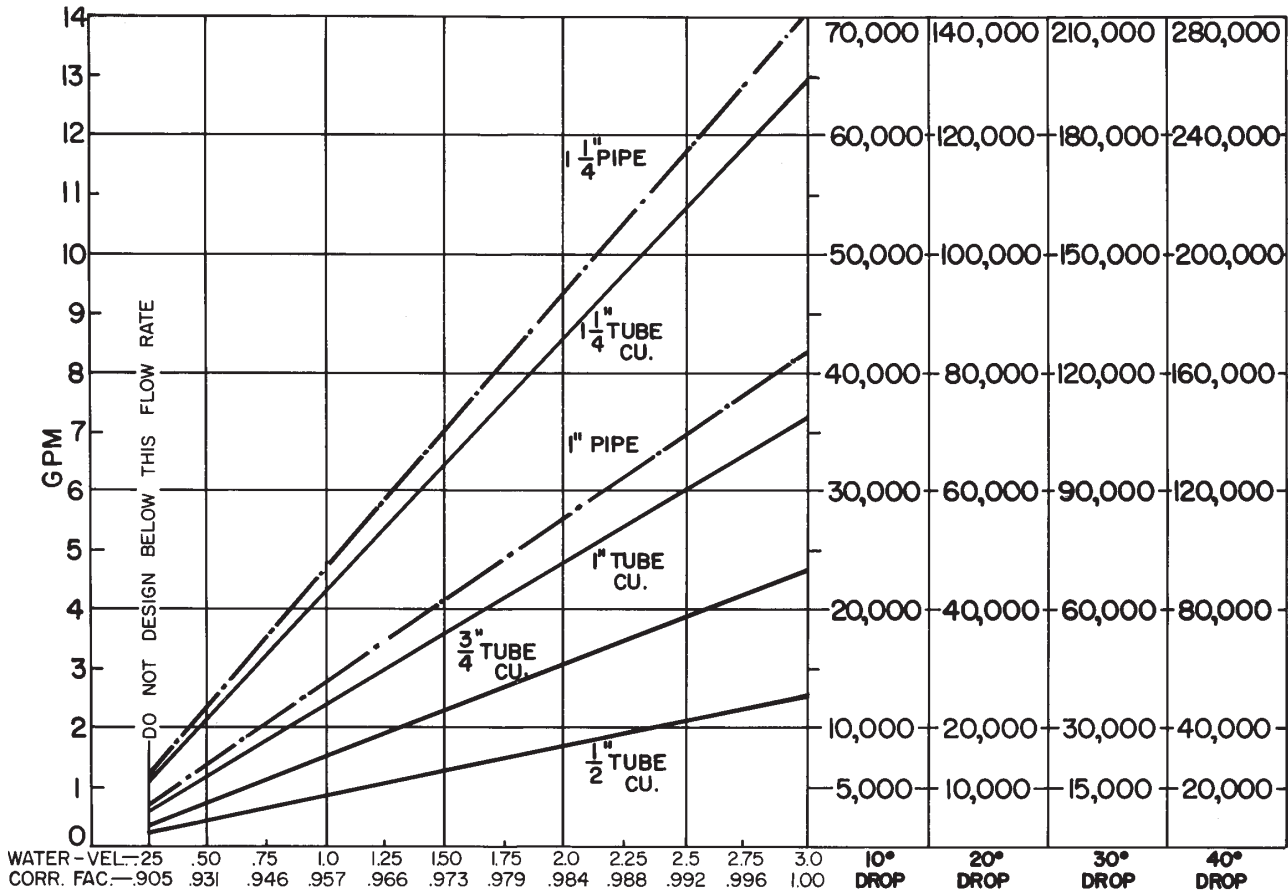

1/2" COP. ALUM.	.180	.233	.333	.533	.916											
3/4" COP. ALUM.	.5	.75	1.125	1.5	2.25	3.16	4.5	6.25								
1" COP. ALUM.	.233	.41	.583	.83	1.166	1.666	2.333	3.166	4.166	5.166	6.166	7.166				
1" PIPE	.37	.79	1.18	1.57	2.00	2.70	3.70	4.80								
1 1/4" COP. ALUM.	.16	.33	.55	.79	1.08	1.33	1.8	2.25	2.26	2.91	3.3					
1 1/4" PIPE	.09	.18	.31	.5	.70	1.0	1.1	1.3	1.6	1.8	2.58	2.3	3.3			

PRESSURE DROP PER 100 LINEAR FT., IN FEET OF HEAD

Design Data

INLET AIR CORRECTION FACTOR

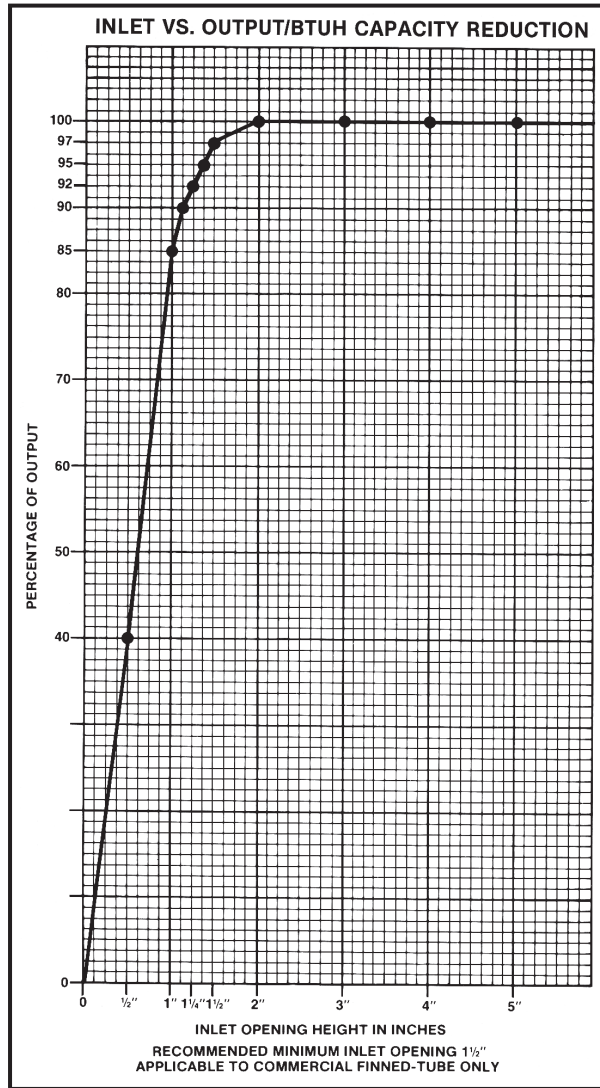

GUARANTEED WORKING PRESSURES

1" IPS — 780 AT TEMPERATURES UP TO 650°F.
 1 1/4" IPS — 660 AT TEMPERATURES UP TO 650°F.
 2" IPS — 405 AT TEMPERATURES UP TO 650°F.
 1 1/4" CU — 194 AT TEMPERATURES UP TO 300°F.
 1" CU — 204 AT TEMPERATURES UP TO 300°F.
 3/4" CU — 218 PSI AT TEMPERATURES UP TO 300°F.
 MAXIMUM PRESSURES AT OTHER TEMPERATURES ARE AVAILABLE UPON REQUEST.

RATE OF PITCH FOR STEAM 1/2" DROP OVER 20 FT. RUN.

PIPE WATER CAPACITIES AND QUANTITIES CIRCULATED AT VELOCITY OF 3* FEET PER SECOND			
Pipe Size	Gals. Per Linear Ft.	Gals./Min. @ 3' Sec. Vel.*	Lbs./Hr. @ 3' Sec. Vel.*
1/2"	.016	2.88	1440
3/4"	.023	4.14	2070
1"	.040	7.20	3600
1 1/4"	.063	11.34	5660
1 1/2"	.102	18.36	9160
2"	.170	30.60	15300
2 1/2"	.275	49.50	24850
3"	.390	70.20	35000

*3 Ft./Sec. Velocity is Basic for Hot Water Rating Factors Shown on this Page.

$$\text{VELOCITY FT./SEC.} = \frac{\text{LBS. PER HOUR}}{(\text{GALS. PER FT.}) (3600) (8.3)}$$

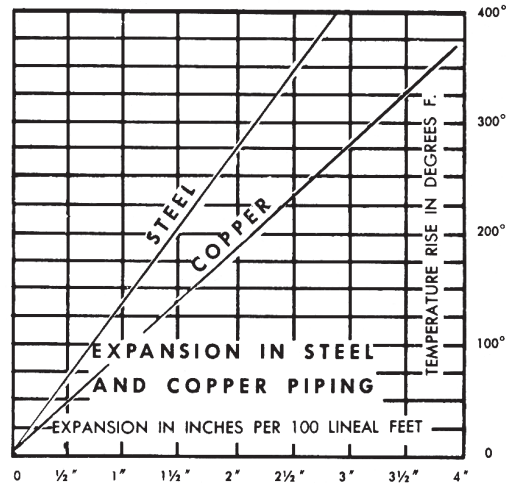

GLYCOL CORRECTION FACTORS

Fluid Temperature 200°F

% Solution	Ethylene Glycol	Propylene Glycol
20	.952	.988
30	.921	.968
40	.888	.943
50	.852	.912

Fluid Temperature 180°F

% Solution	Ethylene Glycol	Propylene Glycol
20	.946	.982
30	.913	.961
40	.879	.934
50	.842	.902

Fluid Temperature 140°F

% Solution	Ethylene Glycol	Propylene Glycol
20	.934	.97
30	.898	.946
40	.861	.916
50	.821	.881

ALTITUDE FACTORS

Approximate factors for convective heat value at varying altitudes

Altitude	Ferrous Units	Copper Alum. Units
Sea Level	1.000	1.000
1,000 ft.	.984	.969
2,000 ft.	.968	.938
3,000 ft.	.952	.908
4,000 ft.	.936	.878
5,000 ft.	.920	.850
6,000 ft.	.904	.822
7,000 ft.	.889	.795
8,000 ft.	.874	.768
9,000 ft.	.859	.743
10,000 ft.	.844	.718
15,000 ft.	.771	.603
20,000 ft.	.703	.502

Design Data

CORRECTION FACTORS FOR STEAM PRESSURES AND AIR TEMPERATURES OTHER THAN STANDARD

STEAM		ENTERING AIR TEMPERATURE, °F														
Pressure		Temp.			STD											
Gauge	Abs. Psi	°F	45	55	65	70	75	80	85	90	100	110	120	130	140	150
(Vac) 15" Hg	7.32	178.9	0.90	0.80	0.70	0.65	0.60	0.56	0.51	0.45	0.39	0.32	0.25	0.18	0.13	0.08
(Vac) 10"	9.78	192.2	1.02	0.91	0.81	0.76	0.71	0.66	0.62	0.55	0.48	0.40	0.33	0.26	0.20	0.14
(Vac) 5"	12.25	202.9	1.11	1.00	0.90	0.85	0.79	0.75	0.70	0.63	0.56	0.48	0.40	0.33	0.27	0.20
(Vac) 0 Psi	14.696	212.0	1.19	1.09	0.97	0.92	0.87	0.82	0.77	0.70	0.63	0.54	0.46	0.38	0.31	0.25
▶ .899	15.595	215.0	1.22	1.11	1.00	0.95	0.90	0.84	0.80	0.75	0.65	0.57	0.48	0.40	0.33	0.26
5	19.70	227.1	1.34	1.22	1.11	1.05	1.00	0.95	0.90	0.81	0.75	0.66	0.57	0.49	0.41	0.34
10	24.70	239.4	1.45	1.33	1.22	1.17	1.11	1.05	1.00	0.91	0.85	0.75	0.66	0.58	0.50	0.42
15	29.70	249.8	1.55	1.43	1.31	1.26	1.20	1.14	1.09	1.00	0.94	0.84	0.75	0.66	0.57	0.49
20	34.70	258.8	1.63	1.52	1.40	1.33	1.28	1.23	1.17	1.07	1.02	0.92	0.82	0.73	0.64	0.55
25	39.70	266.8	1.71	1.59	1.47	1.41	1.36	1.30	1.25	1.15	1.09	0.98	0.89	0.80	0.71	0.62
30	44.70	274.0	1.78	1.66	1.54	1.48	1.42	1.37	1.31	1.21	1.15	1.05	0.95	0.85	0.76	0.68
40	54.70	286.7	1.91	1.79	1.66	1.61	1.54	1.49	1.43	1.32	1.27	1.16	1.06	0.97	0.87	0.78
50	64.70	297.7	2.02	1.90	1.77	1.71	1.65	1.60	1.54	1.42	1.37	1.26	1.16	1.06	0.96	0.87
60	74.70	307.3	2.10	2.00	1.87	1.81	1.75	1.69	1.63	1.51	1.47	1.35	1.25	1.15	1.05	0.95
70	84.70	316.0	2.20	2.09	1.95	1.89	1.83	1.77	1.71	1.59	1.55	1.44	1.33	1.23	1.12	1.03
80	94.70	323.9	2.27	2.17	2.03	1.97	1.91	1.85	1.80	1.69	1.63	1.52	1.41	1.31	1.20	1.10
90	104.70	331.2	2.36	2.24	2.11	2.05	1.98	1.93	1.87	1.74	1.70	1.59	1.48	1.38	1.28	1.17
100	114.70	337.9	2.43	2.31	2.18	2.11	2.05	2.00	1.94	1.81	1.77	1.65	1.54	1.44	1.33	1.23
125	139.70	352.9	2.59	2.47	2.33	2.27	2.21	2.16	2.10	1.96	1.92	1.80	1.69	1.59	1.48	1.38
150	164.70	365.9	2.73	2.62	2.47	2.43	2.35	2.29	2.23	2.08	2.05	1.94	1.82	1.72	1.61	1.51
175	189.70	377.4	2.86	2.74	2.60	2.54	2.47	2.41	2.35	2.21	2.17	2.05	1.95	1.85	1.73	1.63
200	214.70	387.8	2.95	2.85	2.71	2.63	2.58	2.52	2.47	2.31	2.29	2.17	2.06	1.96	1.84	1.75

From Keenan and Keyes — Linear Interpolation.

Note: Gauge pressure should be corrected for altitude.

CORRECTION FACTORS FOR WATER TEMPERATURES AND AIR TEMPERATURES OTHER THAN STANDARD

AVERAGE WATER TEMP. °F	ENTERING AIR TEMPERATURE, °F														
	45	55	STD	70	75	80	85	90	95	100	110	120	130	140	150
90	.19	.13	.11	.06											
100	.25	.19	.15	.11	.08	.06									
110	.31	.25	.20	.16	.13	.11	.08	.06							
120	.38	.31	.26	.21	.19	.16	.13	.11	.08	.06					
130	.45	.38	.33	.28	.25	.21	.19	.16	.13	.11	.06				
140	.53	.45	.40	.34	.31	.28	.25	.21	.19	.16	.11	.06			
150	.61	.53	.45	.41	.38	.34	.31	.28	.25	.21	.16	.11	.06		
160	.69	.61	.53	.49	.45	.41	.38	.34	.31	.28	.21	.16	.11	.06	
170	.77	.69	.61	.57	.53	.49	.45	.41	.38	.34	.28	.21	.16	.11	.06
180	.86	.77	.69	.65	.61	.57	.53	.49	.45	.41	.34	.28	.21	.16	.11
190	.95	.86	.78	.73	.69	.65	.61	.57	.53	.49	.41	.34	.28	.21	.16
200	1.05	.95	.86	.82	.77	.73	.69	.65	.61	.57	.49	.41	.34	.28	.21
210	1.14	1.05	.95	.91	.86	.82	.77	.73	.69	.65	.57	.49	.41	.34	.28
▶ 215 (STD.)	1.19	1.09	1.00	.95	.91	.86	.82	.77	.73	.69	.61	.53	.45	.38	.31
220	1.24	1.14	1.05	1.00	.95	.91	.86	.82	.77	.73	.65	.57	.49	.41	.34
230	1.34	1.24	1.14	1.09	1.05	1.00	.95	.91	.86	.82	.73	.65	.57	.49	.41
240	1.44	1.34	1.25	1.19	1.14	1.09	1.05	1.00	.95	.91	.82	.73	.65	.57	.49
250	1.55	1.44	1.34	1.29	1.24	1.19	1.14	1.09	1.05	1.00	.91	.82	.73	.65	.57
260	1.66	1.55	1.44	1.39	1.34	1.29	1.24	1.19	1.14	1.09	1.00	.91	.82	.73	.65
270	1.76	1.66	1.55	1.50	1.44	1.39	1.34	1.29	1.24	1.19	1.09	1.00	.91	.82	.73
280	1.87	1.76	1.66	1.60	1.55	1.50	1.44	1.39	1.34	1.29	1.19	1.09	1.00	.91	.82
290	1.99	1.87	1.76	1.71	1.66	1.60	1.55	1.50	1.44	1.39	1.29	1.19	1.09	1.00	.91
300	2.10	1.99	1.87	1.82	1.76	1.71	1.66	1.60	1.55	1.50	1.39	1.29	1.19	1.09	1.00

In the interest of product improvement, Sterling reserves the right to make changes without notice.