

# SPACE PAK®

## MODEL WCSP-J & WCSP-JV INSTALLATION, OPERATION & MAINTENANCE MANUAL

Central Hydronic Coil Series  
2 to 5 Tons  
Fan Coil Unit/Air Supply  
Components



### SECTION 1: INTRODUCTION

SpacePak System Design.....	2
Code Compliance.....	2
Air Distribution Requirements.....	2
Model Number Description.....	2
Air Distribution Components.....	3-4
High Altitude Guidelines.....	6
Shipment of Unit.....	6

### SECTION 2: SYSTEM INSTALLATION

Step 1: Locating The Unit.....	7
Step 2: Cutting Return Air Opening.....	12
Step 3: Attaching Supply Air Plenum Adapter.....	12
Step 4: Setting The Unit.....	13
Step 5: Connecting Refrigerant Lines.....	14
Step 6: Installing The Condensate Trap & Line.....	15
Step 7: Installing Air Distribution Components.....	15
Step 8: Retrofit to B & C Series Units.....	19, 20
Step 9: Wiring The Unit.....	21

### SECTION 3: START-UP & COMMISSIONING

Controls Overview.....	25
System Commissioning.....	31
Charging Cooling Only Systems.....	34
Factors Affecting the Balance of the System.....	37

### SECTION 4: MAINTENANCE & TROUBLESHOOTING

Before Each Cooling Season.....	38
If System Fails To Operate.....	38
Troubleshooting Guide.....	39, 40
Troubleshooting Flow Charts.....	41-43
Service/Troubleshooting Form.....	45
Parts List.....	46, 47
<b>PRODUCT REGISTRATION</b> .....	48
<b>WARRANTY INFORMATION</b> .....	49



IN UNITED STATES: 260 NORTH ELM ST. WESTFIELD, MA 01085 (413) 564-5530  
 IN CANADA: 7555 TRANMERE DRIVE, MISSISSAUGA, ONTARIO, L5S 1L4 (905) 670-5888



## SECTION 1: INTRODUCTION

The following terms are used throughout this manual to bring attention to the presence of potential hazards or to important information concerning the product:

**⚠ DANGER** Indicates an imminently hazardous situation which, if not avoided, will result in death, serious injury or substantial property damage.

**⚠ WARNING** Indicates an imminently hazardous situation which, if not avoided, could result in death, serious injury or substantial property damage.

**⚠ CAUTION** Indicates an imminently hazardous situation which, if not avoided, may result in minor injury or property damage.

**NOTICE:** Used to notify of special instructions on installation, operation or maintenance which are important to equipment but not related to personal injury hazards.

All electrical wiring must be in accordance with the National Electrical Code ANSI/NFPA No. 70-latest edition and any additional state or local code requirements. If an external electrical source is utilized, the fan coil unit, when installed, must be electrically grounded.

**NOTICE:** It is a requirement of the International Mechanical Code (307.2.3) to install a secondary drain or an auxiliary drain pan where damage to any building components will occur as a result of overflow from the equipment drain pan or stoppage in the condensate drain piping from a cooling or an evaporator coil. Follow local code requirements.

**⚠ WARNING** The appliance is not to be used by persons (including children) with reduced physical, sensory or mental capabilities, or lack of experience and knowledge, unless they have been given supervision or instruction.

**⚠ WARNING** Children being supervised are not to play with the appliance.

**⚠ WARNING** The unit is not to be installed above 15,000 ft.

### SPACEPAK SYSTEM DESIGN

The SpacePak WCSP-J/V unit is a hydronic fan coil unit which utilizes chilled or heated water from a chiller or boiler to provide the conditioned air through the specially designed prefabrication preinsulated flexible duct system. The system and its basic components operate the same as in any conventional air-to-air cooling system.

The SpacePak system is covered by the following U.S. Patents: 3,507,354; 3,575,234; 3,596,936; 3,605,797; 3,685,329; 4,045,977; 4,698,982; and 926,673 along with Canadian Patents: 891,292; 923,935; and 923,936.

### CODE COMPLIANCE

Fan coil unit installation must conform to the requirements of the local authority having jurisdiction or, in the absence of such requirements, to the National Board of Fire Underwriters regulations. Fan coil unit meets ETL listing requirements.

### AIR DISTRIBUTION SYSTEM COMPONENT REQUIREMENTS

Air distribution components installation must conform to the requirements of local authority having jurisdiction or, in the absence of such requirements, to the National Fire Protection Association 90A or 90B.

Do not begin the installation of the system without a system layout and material take-off. If a layout plan is not already available and room terminator requirements determined, then refer to the SpacePak Application Manual, SP9, to complete this information. A description of air distribution system components is shown in Figure 1.1.

### WCSP-J - MODEL NUMBER DESCRIPTION

1	2	3	4	5	6	7	8	9	10	11	12
UT			CA			SE	CT	RT	CF	RV	

#### 1,2,3, - Unit Type [UT]

WCSP - Evaporator DX Fan Coil Unit

#### 4,5,6,7 - Capacity [CA]

2430 - 24,000 to 30,000 BTU/Hr. (2-2½ tons)

3642 - 36,000 to 42,000 BTU/Hr. (3-3½ tons)

4860 - 48,000 to 60,000 BTU/Hr. (4-5 tons)

#### 8 - Series [SE]

J - "J" series

#### 9 - Cabinet Type [CT]

H - Horizontal

V - Vertical

#### 10 - Refrigerant Type [RT]

4 - R410A

#### 11 - Cabinet Feature [CF]

M - Modified

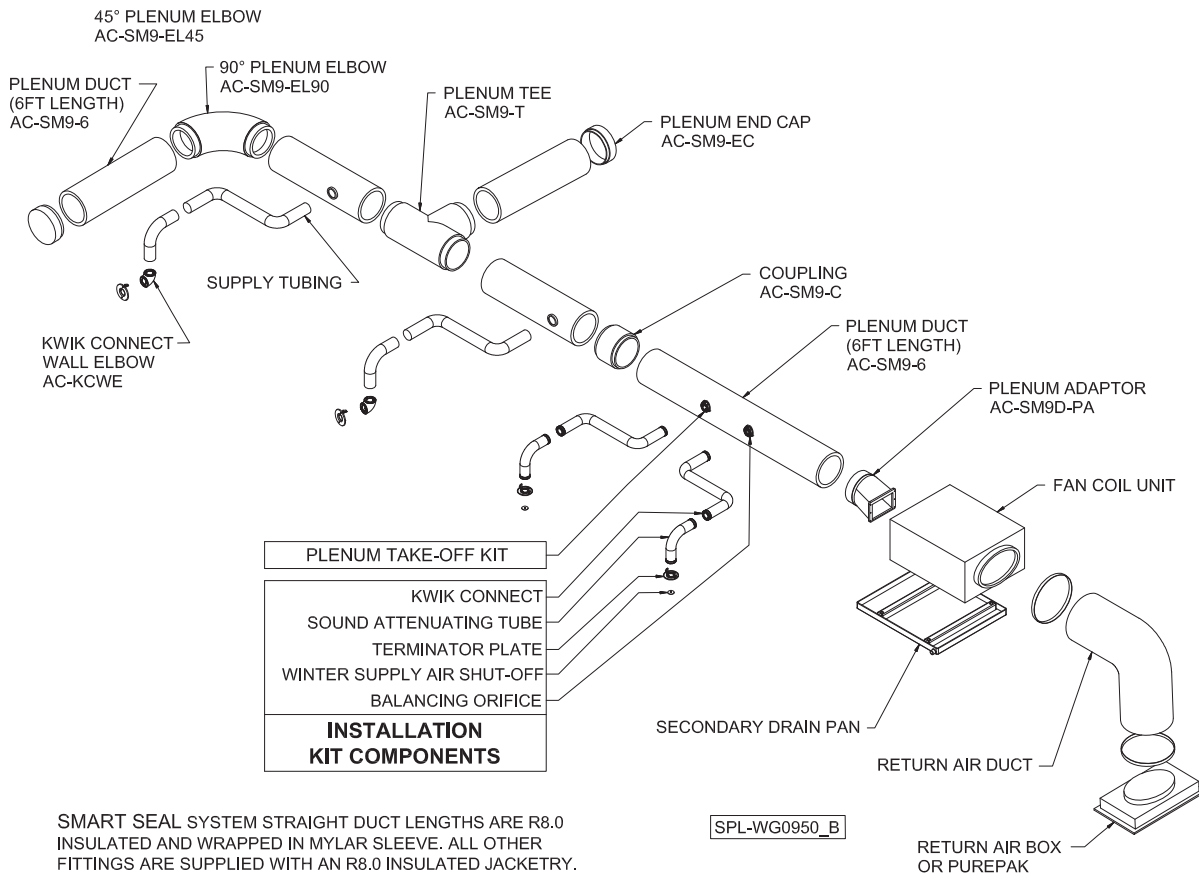
#### 12 - Revision [RV]

A - Standard Control (blue board)

B - Advanced Control (black board)

C - Revised Assemblies

**FIGURE 1.1: AIR DISTRIBUTION SYSTEM COMPONENTS**



SMART SEAL SYSTEM STRAIGHT DUCT LENGTHS ARE R8.0 INSULATED AND WRAPPED IN MYLAR SLEEVE. ALL OTHER FITTINGS ARE SUPPLIED WITH AN R8.0 INSULATED JACKETRY. DUCT COMPONENTS SHOWN WITHOUT FACTORY SUPPLIED R8.0 INSULATED JACKETRY.

**RETURN AIR BOX (BM-9149, AC-RBF-3, BM-9169):**

Each includes filter grill with metal frame, permanent filter, and 2 clamp bands. BM-9149 is for WCSP-2430J. AC-RBF-3 is for WCSP-3642J and BM-9169 is for WCSP-4860J.

**RETURN AIR DUCT (BM-6808-10, BM-6809-10, BM-6839-10):** Flexible, 10 feet long with round shape. BM-6808-10 (15" dia.) for WCSP-2430J. BM-6809-10 (19" dia.) for WCSP-3642J and BM-6839-10 (24" dia.) is for WCSP-4860J.

**PLENUM ADAPTER:** 9" round OR 10" X 10" square metal component to attach plenum duct to fan coil unit.

**PLENUM DUCT & COMPONENTS:** May be 9" round sheet metal or 10" X 10" (O.D.) square, fiberboard duct types as specified by the installing contractor. Above layout is shown as an illustrative Smart Seal assembly reference only.

**R6 SUPPLY TUBING (AC-ST6-100):** Flexible, R6 insulated, 2" I.D. and 3-1/4" O.D. Each section is 100 feet long.

**R8 SUPPLY TUBING (AC-ST8-75):** Flexible, R8 insulated, 2" I.D. and 5-3/8" O.D. Each section is 75 feet long.

**INSTALLATION KITS:** Contains a specified amount of sound attenuating tubes, kwik-connects, terminator

plates (incl. spring clips & screws), winter supply air shut-offs and a balancing orifice set to complete installation of room outlets. Supplied in (2) [AC-IKLT-2] and (5) [AC-IKLT-5] outlet boxed quantities.

**PLENUM TAKE-OFF KIT:** Contains a specific amount of plenum take-offs, gaskets and fasteners to complete installation of room outlets. Take-offs available for round sheet metal or square fiberboard duct as specified by installing contractor. Supplied in (2) [AC-TKMR-2] and (5) [AC-TKMR-5] outlet boxed quantities for round sheet metal and (2) [AC-TKFS-2] and (5) [AC-TKFS-5] outlet boxed quantities for square fiberboard.

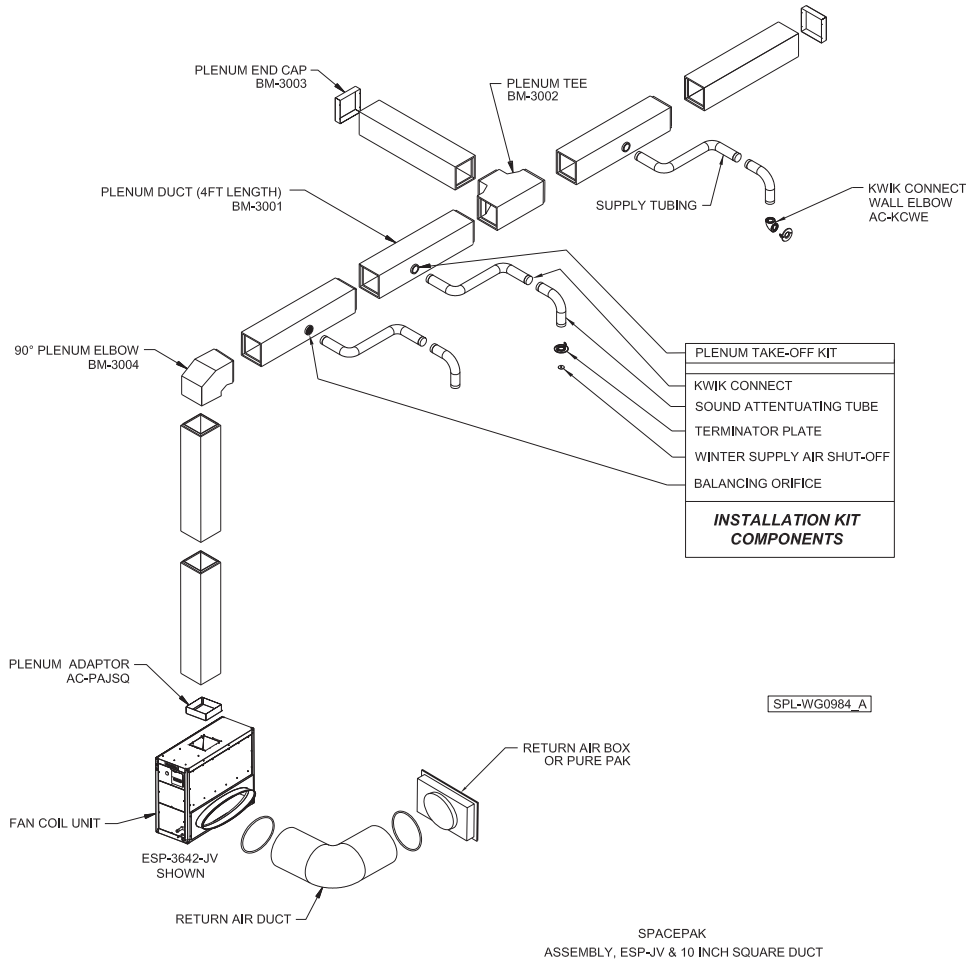
**KWIK CONNECT 90° WALL ELBOW (AC-KCWE):** To allow for wall terminations in 2" X 4" stud spaces.

**SECONDARY DRAIN PAN:** Specifically sized for SpacePak horizontal fan coil units. Constructed of durable polyethylene. Fan coil unit sets directly on top and can be installed with threaded rod.

**PLIERS (SPC-72):** To assure full setting of all clips (fasteners) in plenum take-off (not shown).

**PLENUM HOLE CUTTER (SPC-71-10):** To cut 2" hole in fiber board for plenum take-off installation (not shown).

**FIGURE 1.2: AIR DISTRIBUTION SYSTEM COMPONENTS**



**RETURN AIR BOX (SPC-1D, AC-RBF-3, SPC-3D):** Each includes filter grill with metal frame, permanent filter, and 2 clamp bands. SPC-1D is for WCSP-2430JV. AC-RBF-3 is for WCSP-3642JV and SPC-3D is for WCSP-4860JV.

**RETURN AIR DUCT (SPC-4,5, & 6):** Flexible, 10 feet long with round shape. SPC-4 (15" dia.) for WCSP-2430JV. SPC-5 (19" dia.) for WCSP-3642JV and SPC-6 (24" dia.) is for WCSP-4860JV.

**PLENUM ADAPTER:** 9" round OR 10" x 10" square metal component to attach plenum duct to fan coil unit.  
 Plenum Adapter - 9" Round - AC-PAJ  
 Plenum Adapter - 10" x 10" Square - AC-PAJSQ

**PLENUM DUCT & COMPONENTS:** May be 9" round sheet metal or 10" x 10" (O.D.) square, fiberboard duct types as specified by the installing contractor. Above layout is shown as an illustrative assembly reference only.

**SUPPLY TUBING (SPC-25-100):** Flexible, insulated, 2" I.D. and 3-1/4" O.D. Each section is 100 feet long.

**R6 SUPPLY TUBING (AC-ST6-75):** Flexible, R6 insulated, 2" I.D. and 5-3/8" O.D. Each section is 75 feet long.

**R8 SUPPLY TUBING (AC-ST8-50):** Flexible, R8 insulated, 2" I.D. and 6-1/4" O.D. Each section is 50 feet long.

**INSTALLATION KITS:** Contains a specified amount of sound attenuating tubes, kwik-connects, terminator plates (incl. spring clips & screws), winter supply air shut-offs and a balancing orifice set to complete installation of room outlets. Supplied in (2) [AC-IKLT-2] and (5) [AC-IKLT-5] outlet boxed quantities.

**PLENUM TAKE-OFF KIT:** Contains a specific amount of plenum take-offs, gaskets and fasteners to complete installation of room outlets. Take-offs available for round sheet metal or square fiberboard duct as specified by installing contractor. Supplied in (2) [AC-TKMR-2] and (5) [AC-TKMR-5] outlet boxed quantities for round sheet metal and (2) [AC-TKFS-2] and (5) [AC-TKFS-5] outlet boxed quantities for square fiberboard.

**KWIK CONNECT WALL ELBOW (AC-KCWE):** To allow for wall terminations in 2" x 4" stud spaces.

**PLIERS (SPC-72):** To assure full setting of all clips (fasteners) in plenum take-off (not shown).

**PLENUM HOLE CUTTER (SPC-71-10):** To cut 2" hole in fiber board for plenum take-off installation (not shown).

## Plenum Duct

The plenum duct can be run in practically any location accessible for the attachment of the supply tubing (see suggested layouts in Figure 1.3). The plenum is normally located in the attic or basement, and it is usually more economical to run the plenum where it will appreciably shorten the lengths of two or more supply runs.

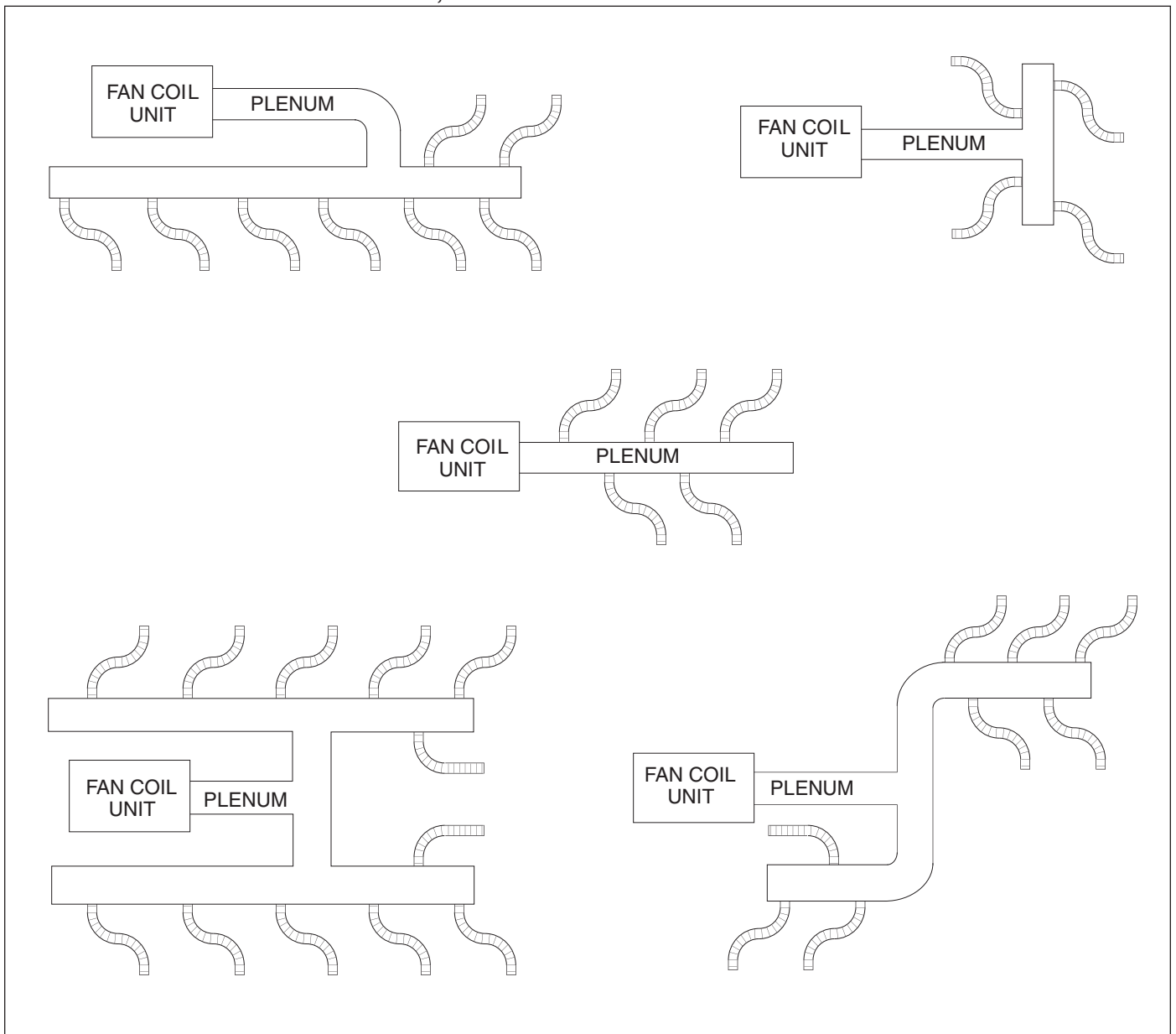
In some two-story split level homes, it may be advantageous to go from one level to another with the plenum duct. Whenever necessary, either between floors or along the ceiling, the small size of the plenum makes it easy to box in.

The fan coil unit is designed to operate with a total external static pressure of 1.3 inches of water column. Excessive static pressure increases the air flow in individual runs and may cause some or all terminators to be noisy.

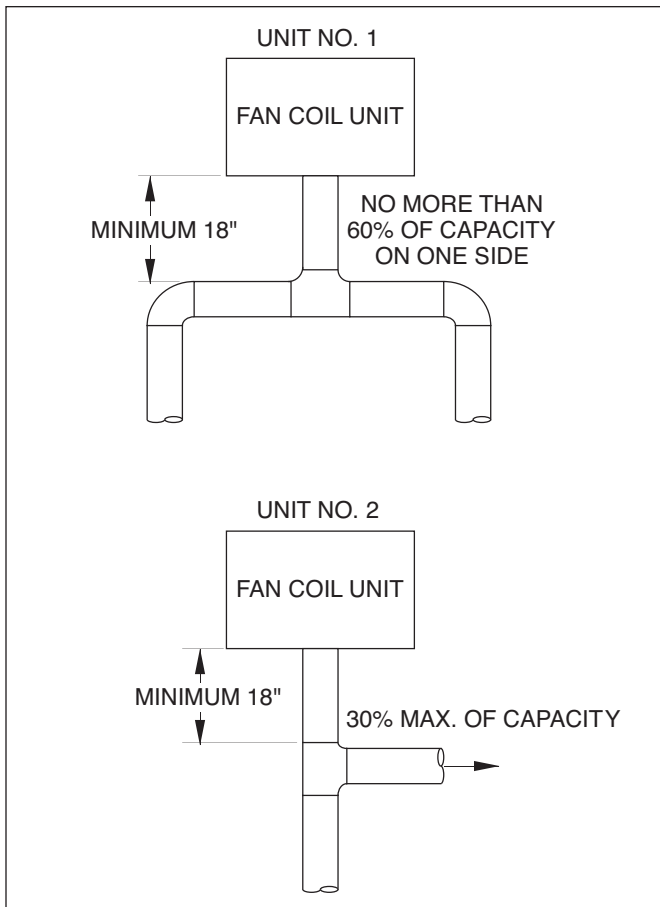
For systems designed with a bullhead tee installed as on Unit No. 1 (Figure 1.4), the best results are obtained if not more than 60% of the total number of system outlets are attached to any one branch of the tee. For systems with a branch tee installed as on Unit No. 2 (Figure 1.4), not more than 30% of the total number of system outlets should be attached to the perpendicular branch of the tee.

**NOTE: For installations replacing B or C series units refer to retrofit instructions on page 17.**

**FIGURE 1.3: COMMON DUCTING LAYOUT. FOR REFERENCE ONLY. ALL SPACEPAK DUCTING RULES FOR SIDE BRANCHES, BULL HEAD TEES ETC.. SHOULD BE FOLLOWED**



**FIGURE 1.4: ESP-3642/4860J INSTALLATIONS**



The larger system capacities (WCSP-3642/4860J) are effected more by higher system static pressure than the smaller systems. Installation of the plenum tee closer than the minimum indicated in Figure 1.4 will reduce performance of the system. No supply runs should be installed between unit outlet and this tee. Static readings on system should be taken before tee.

**Supply Tubing**

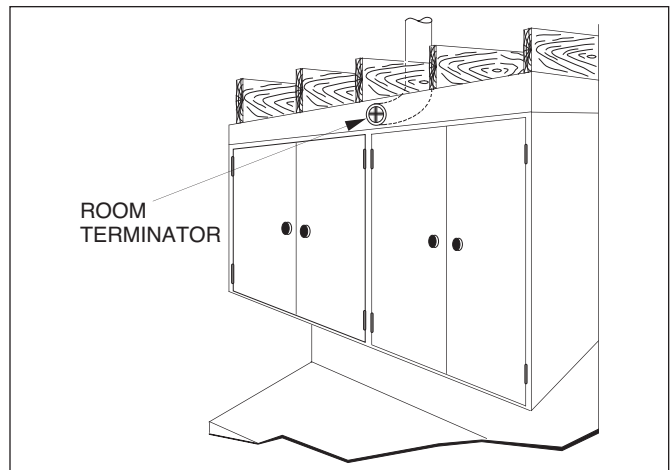
In the case of two-story or split-level applications, supply tubing may run from one story to another. It is small enough to go in stud spaces, but this is often difficult in older homes because of hidden obstructions in stud spaces. It is more common to run the supply tubing from the attic down through second story closets to the first story terminators.

Supply tubing runs in the corners of the second story rooms can be boxed in and are hardly noticeable since overall diameter is only 3-1/4".

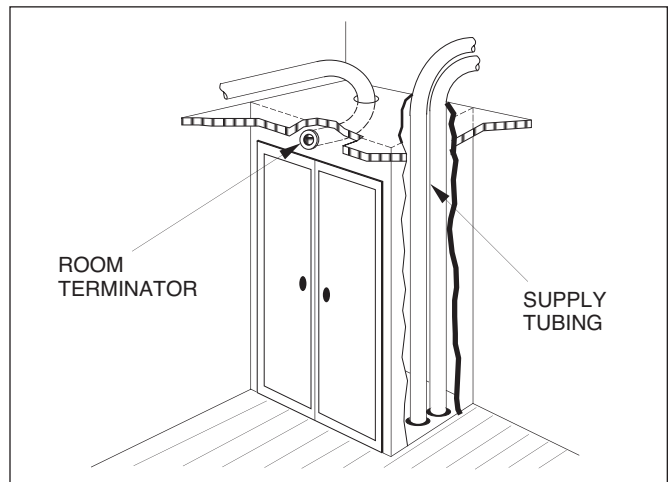
**Room Terminators**

Terminators should be located primarily in the ceiling or floor for vertical discharge or high on a wall for horizontal discharge. Installation of horizontally discharged terminators is assisted with the SpacePak 90° wall elbow. Two excellent spots for horizontal discharge are in the soffit area above kitchen cabinets (see Figure 1.5) and in the top portion of closets (see Figure 1.6).

**FIGURE 1.5: TERMINATOR IN SOFFIT AREA**



**FIGURE 1.6: TERMINATOR IN CLOSET TOP AREA**



Terminators should always be out of normal traffic patterns to prevent discharge air from blowing directly on occupants. They also should not be located directly above shelves or large pieces of furniture. Outside wall or corner locations are recommended if the room has more than one outside wall. Locating terminators away from interior doors prevents short cycling of air to the return air box.

**SHIPMENT OF UNIT**

Each fan coil unit is shipped in a single carton. Packed with the unit, there are vibration isolation pads, a condensate trap assembly and a factory installed primary float switch.

**NOTICE: For high altitude systems use the following chart as a guideline for number of outlets.**

ALTITUDE	MINIMUM NO. OF OUTLETS PER TON
5000 - 6500'	8
6500' and above	9

## SECTION 2: SYSTEM INSTALLATION

**NOTICE:** Before proceeding with the installation, we recommend reading through this section of the manual for an overall understanding of the air conditioning fan coil unit and air distribution system component installation procedures.

### Step 1: Locating the Unit

The fan coil unit may be installed in an unconditioned space (as long as it is protected from the weather) such as an attic, garage or crawlspace, or a conditioned space such as a basement, closet or utility room (see dimensions in Figures 2.2, 2.3 and 2.4).

When selecting a location, consider the location of the unit in relation to the return air box or filter box as shown in Figure 2.5. The return air duct should have at least one 90° bend to avoid unnecessary sound feedback to the living space from the fan coil unit.

When selecting a location, consider the layout of the plenum duct, supply tubing, refrigerant lines and condensate drain line.

When installing the unit above a finished ceiling or living space, install a secondary drain pan. Always follow local code requirements.

**FIGURE 2.1: MODEL WCSP-J SPECIFICATIONS**

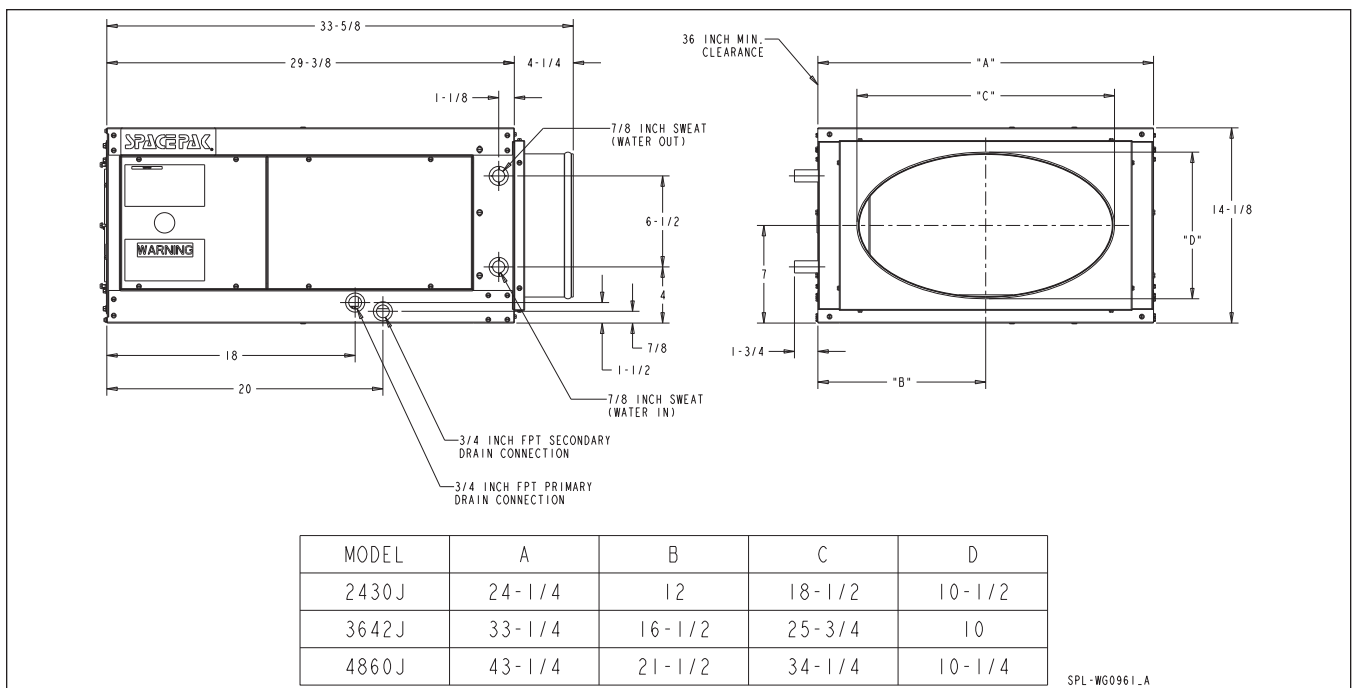
Model	System Capacity (Nom. Tons)	Electrical Characteristics*	Maximum Current Ampacity (230V)	Maximum Current Ampacity (115V)	Rating of Over Current Protective Device (230V)	Rating of Over Current Protective Device (115V)	Connections				Maximum Operating Pressure for Heat Exchanger	Short Circuit Current Rating	Min and Max Operating Water Temperatures	Min and Max Operating Water Pressures
							Suction Line (O.D.)	Liquid Line (O.D.)	Cond. Drain (FPT)	Return Inlet (Dia.)				
WCS2430JH/V	2 - 2 1/2	230/60/1	9.5 A	13.25 A	15 A	20 A	7/8"	3/8"	3/4"	15"	60 PSI	5 kA	32°F - 200°F	0 - 60 PSI
WCS3642JH/V	3 - 3 1/2	230/60/1								19"				
WCS4860JH/V	4 - 5	230/60/1								24"				

\*Unit includes optional conversion kit to 115V.

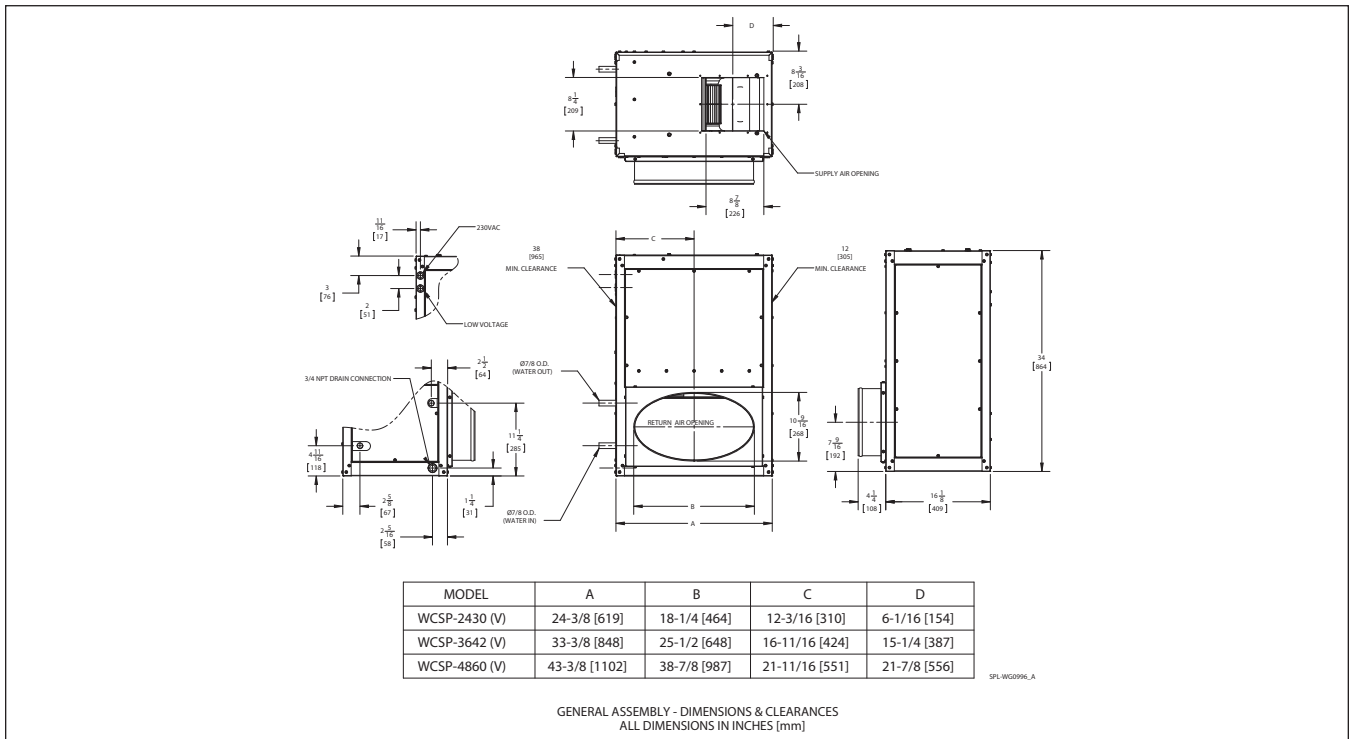
Model	System capacity (Nom. Tons)	Blower				Coil		Ship. Wt. (lbs)	
		Std. CFM @ 1.5" W.C.	Wheel Dia. and Width	Motor HP	115V/230V F.L. Amps*	No. of Rows Deep	Flow Rate per Ton (GPM)	J	JV
WCSP2430JH/V	2 - 2-1/2	440, 550	10" x 6"	3/4	5.6/2.8	6	2.4	105	108
WCSP3642JH/V	3 - 3-1/2	660, 850	10" x 6"	3/4	7.6/4	6	2.4	123	130
WCSP4860JH/V	4 - 5	880, 1150	10" x 6"	3/4	10.6/5.4	6	2.4	144	152

\*Unit includes optional conversion kit to 115V.

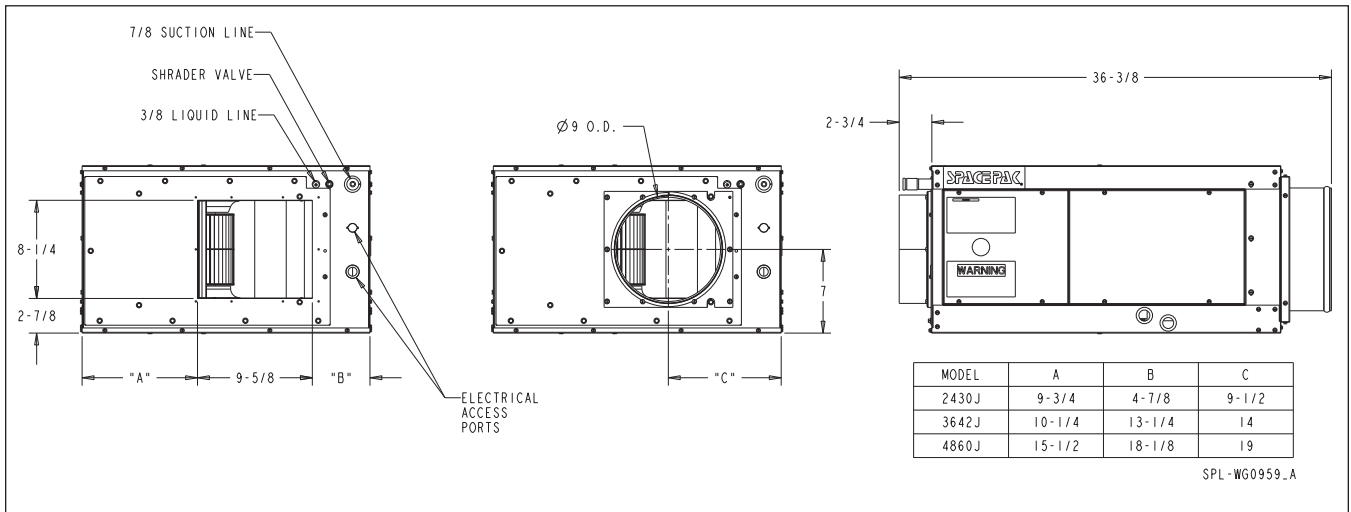
**FIGURE 2.2: UNIT DIMENSIONS AND CLEARANCES (inches)**



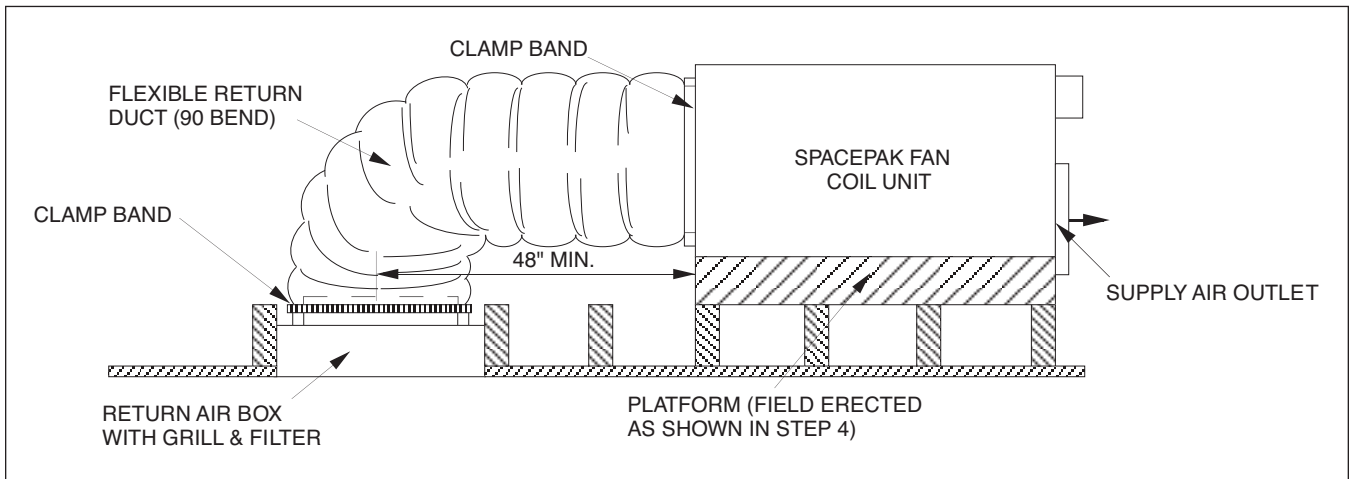
**FIGURE 2.3: VERTICAL UNIT DIMENSIONS AND CLEARANCES (Inches)**



**FIGURE 2.4: CONNECTION LOCATIONS AND ASSEMBLED PLENUM ADAPTER DIMENSIONS**

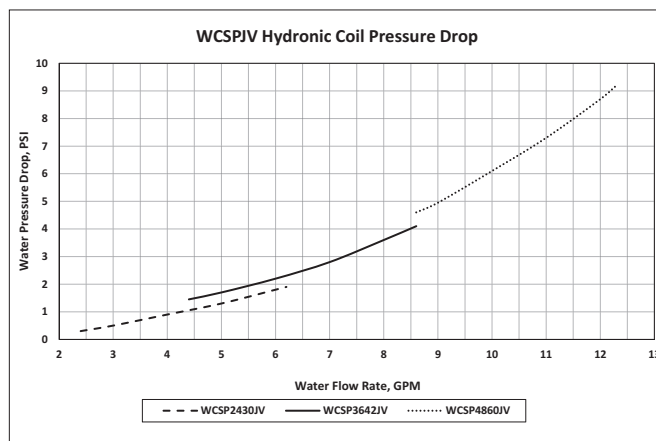
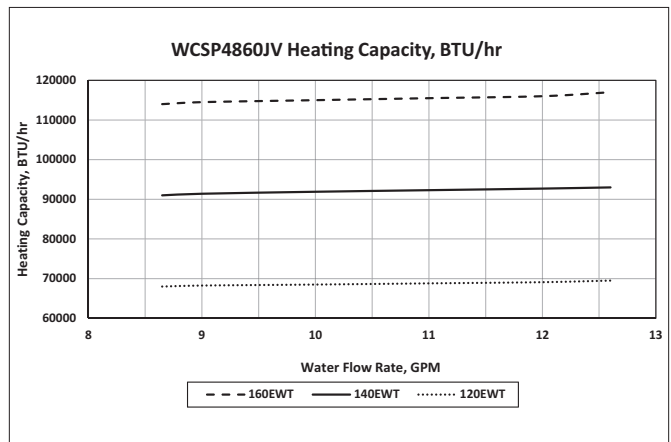
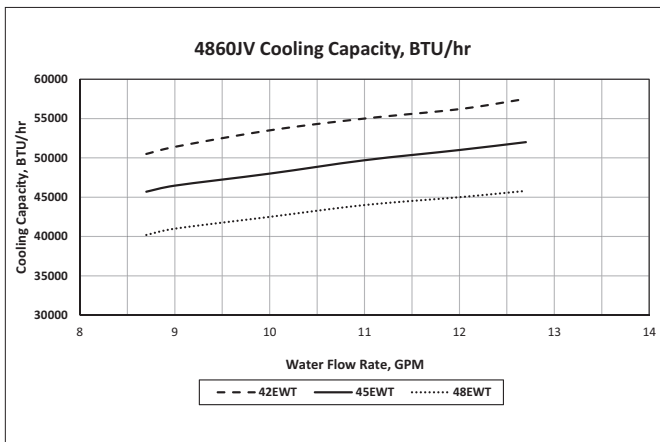
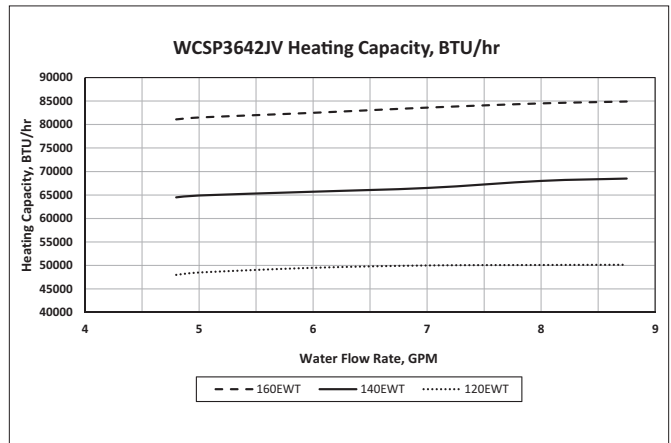
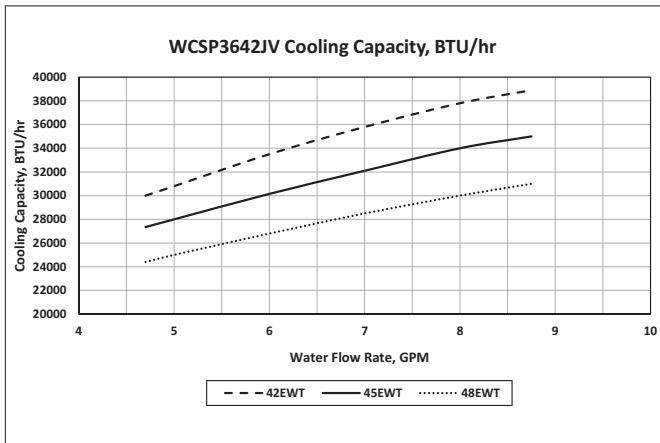
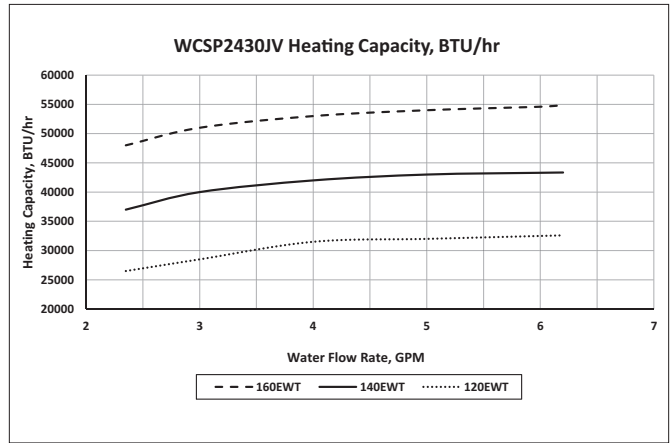
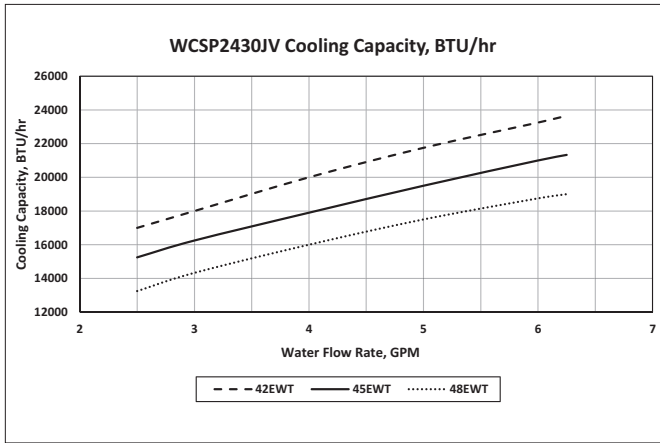


**FIGURE 2.5: TYPICAL UNIT INSTALLATION**

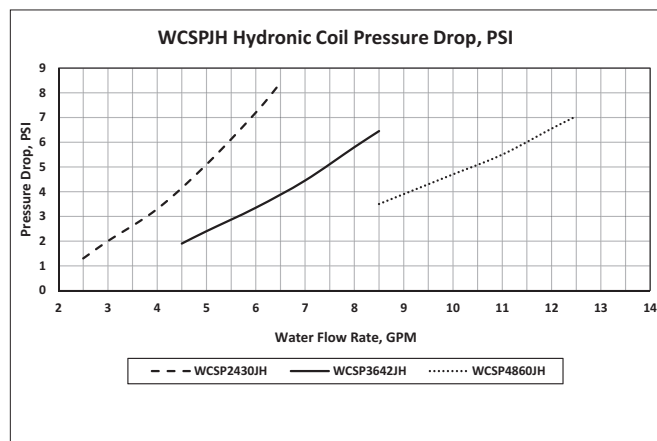
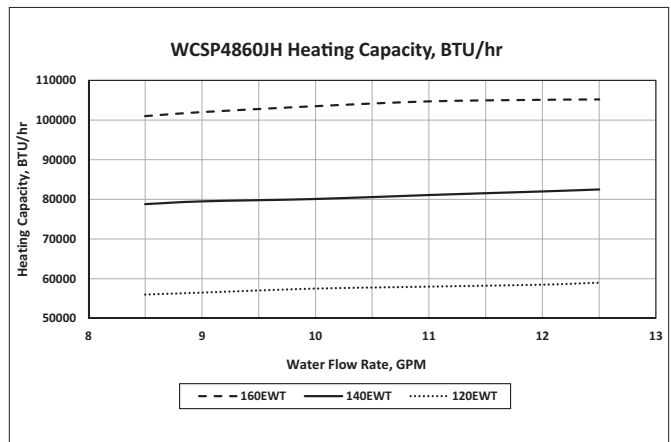
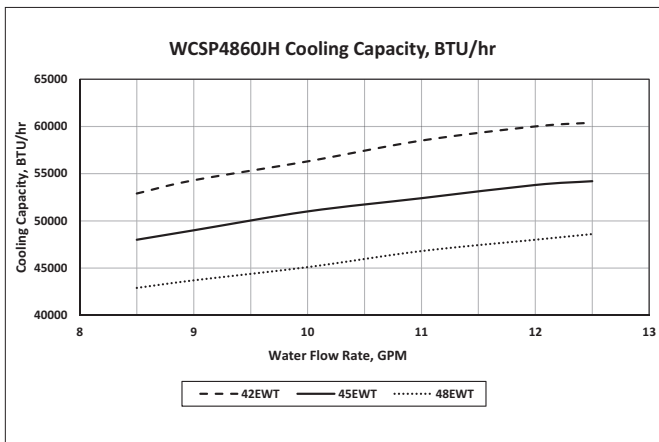
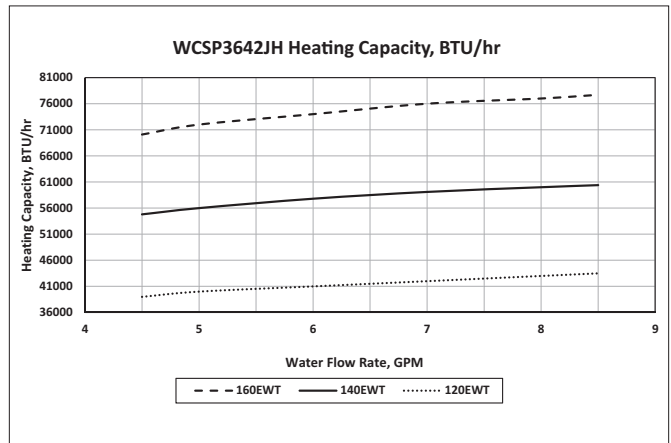
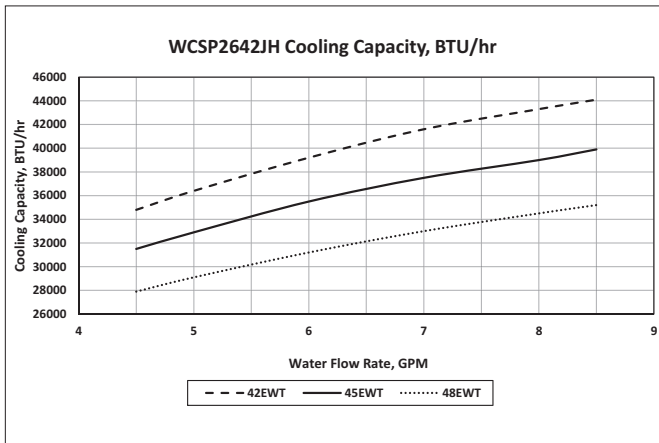
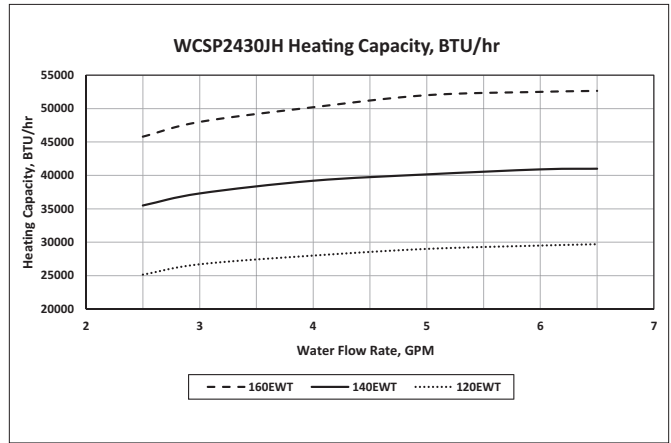
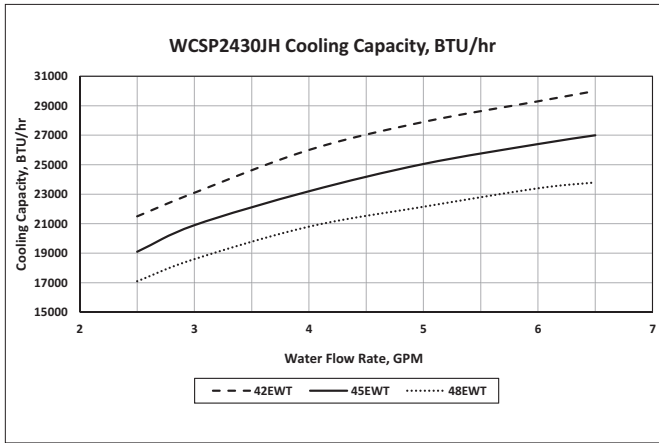




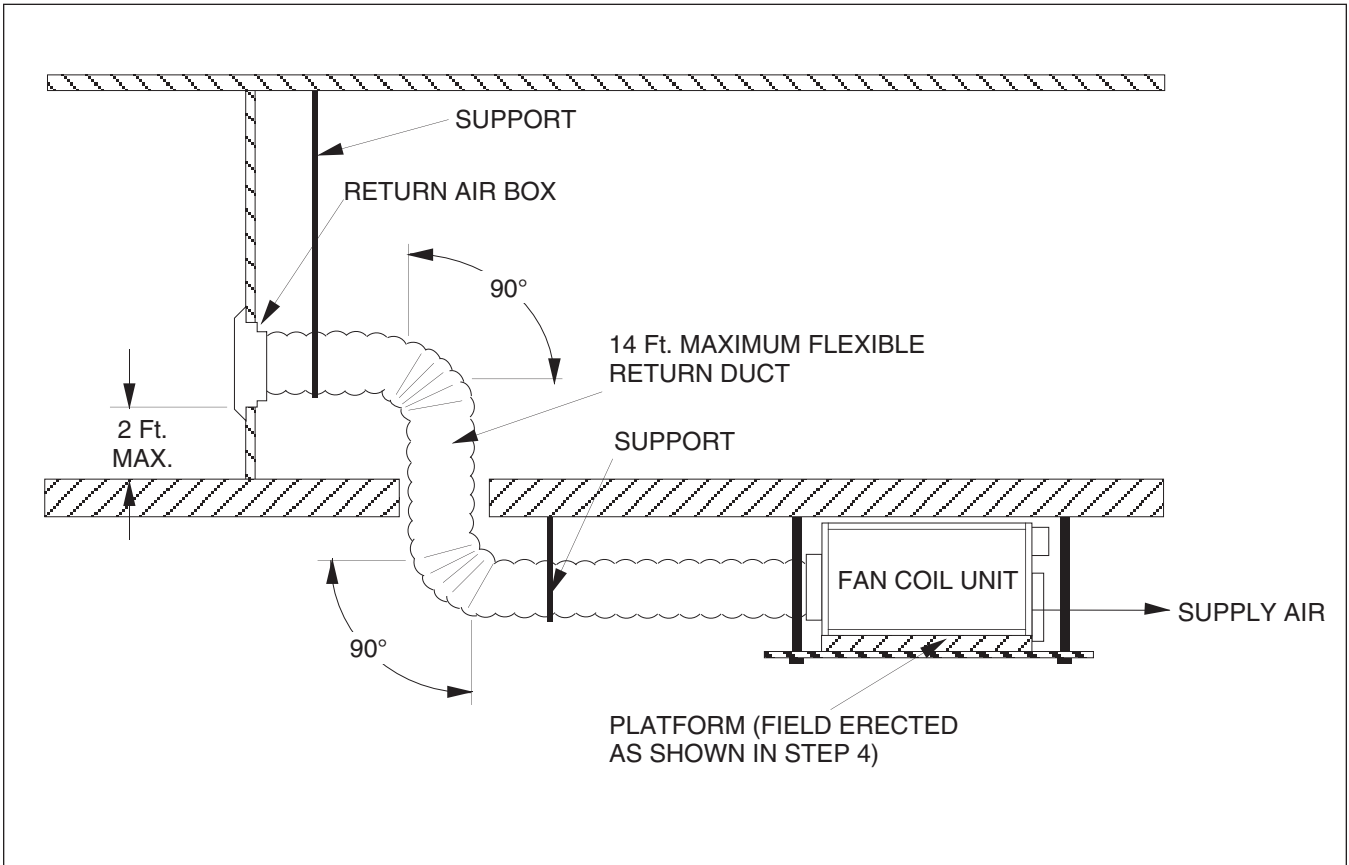
**WCSJV (Vertical Air Handler) Coil Capacity and Pressure Drop All values based on pure water**



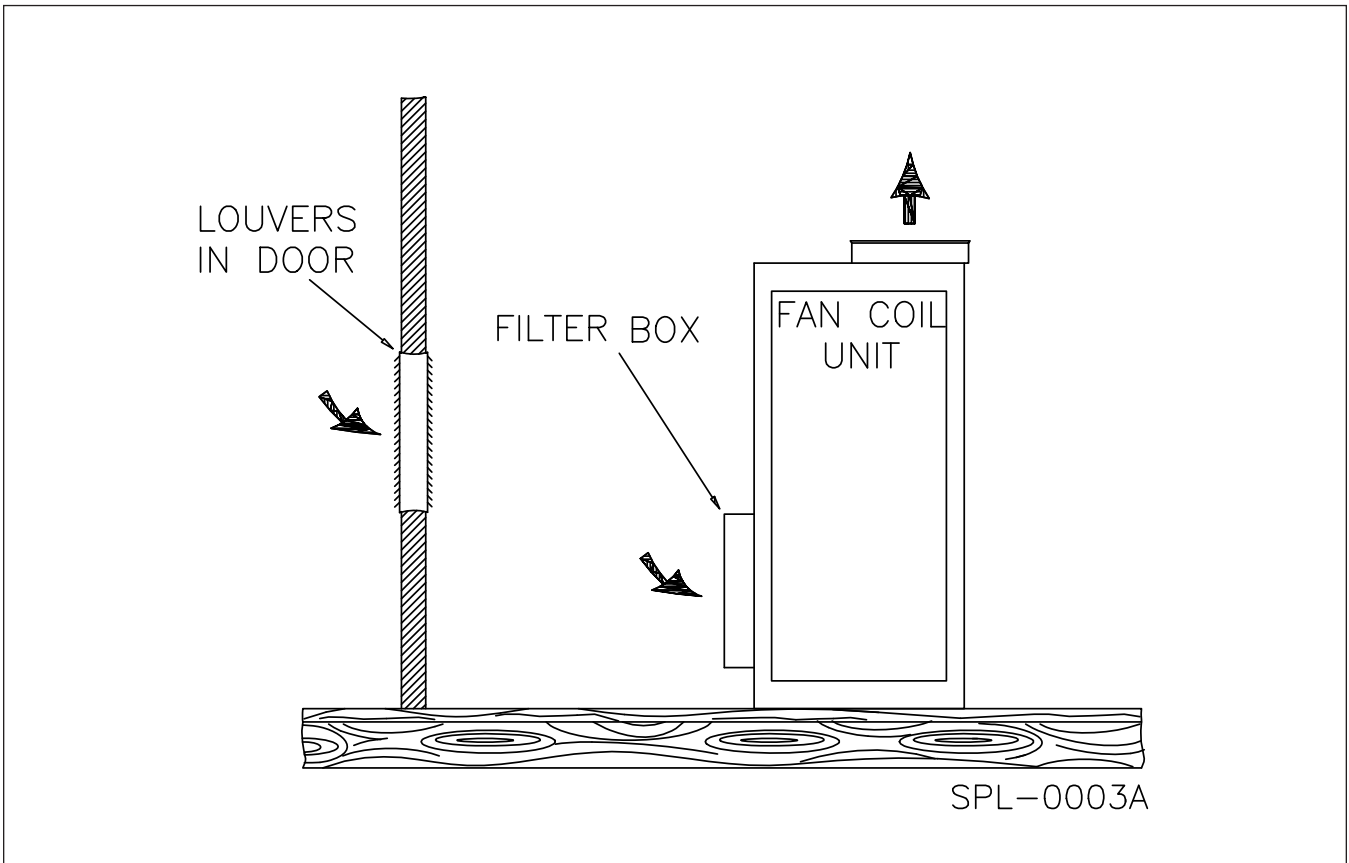
**WCSJH (Horizontal Air Handler) Coil Capacity and Pressure Drops All values based on pure water**



**FIGURE 2.6: HORIZONTAL AIR FLOW UNIT INSTALLATION**



**FIGURE 2.7: TYPICAL INSTALLATION WITHOUT DUCTED RETURN**



## Step 2: Cutting Return Air Opening

Select exact location for return air box. Avoid installing box in dining room, living room, kitchen, etc., unless return air duct can be installed with at least two 90° bends (accomplished by splicing two return air ducts together.)

For attic installations to raise fan coil unit up through opening, cut return air opening 14-1/2" wide by the "A" dimension (Figure 2.8) of appropriate unit size. These openings will accommodate the return air box with sufficient frame lip to cover the opening (see Figure 2.8).

**NOTICE: The return air adapter may need to be removed from the unit to fit through the opening cut-out.**

If joists are on 16" centers, the 14-1/2" width of the return air box should fit between successive joists. Where joists run in the opposite direction, or to properly center the return, it may be necessary to cut joists and install headers.

For all wall return applications, cut the return air opening to accommodate the return air box according to the same dimensions. Remember, location of opening must allow for a 90° bend in the return air duct.

Check the opening for proper fit of the return air box. Do not install the return air box until the installation of the entire SpacePak system is completed, if you want to fit materials up through this hole.

## Step 3: Attaching Supply Air Plenum Adapter

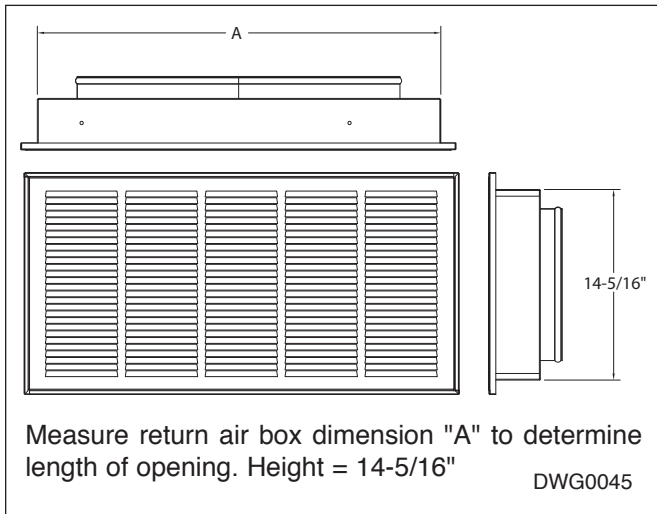
**NOTICE: If unit is to be located in the attic and installed through ceiling joists, attach supply plenum adapter in attic.**

### A. HORIZONTAL DISCHARGE:

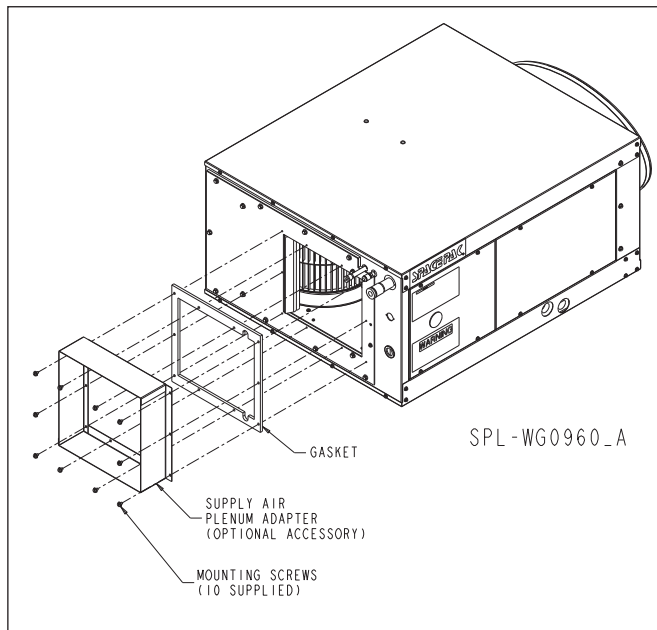
Refer to Figure 2.10 and duct installation instructions supplied with fan coil unit.

**NOTICE: Allow space on sides for servicing.**

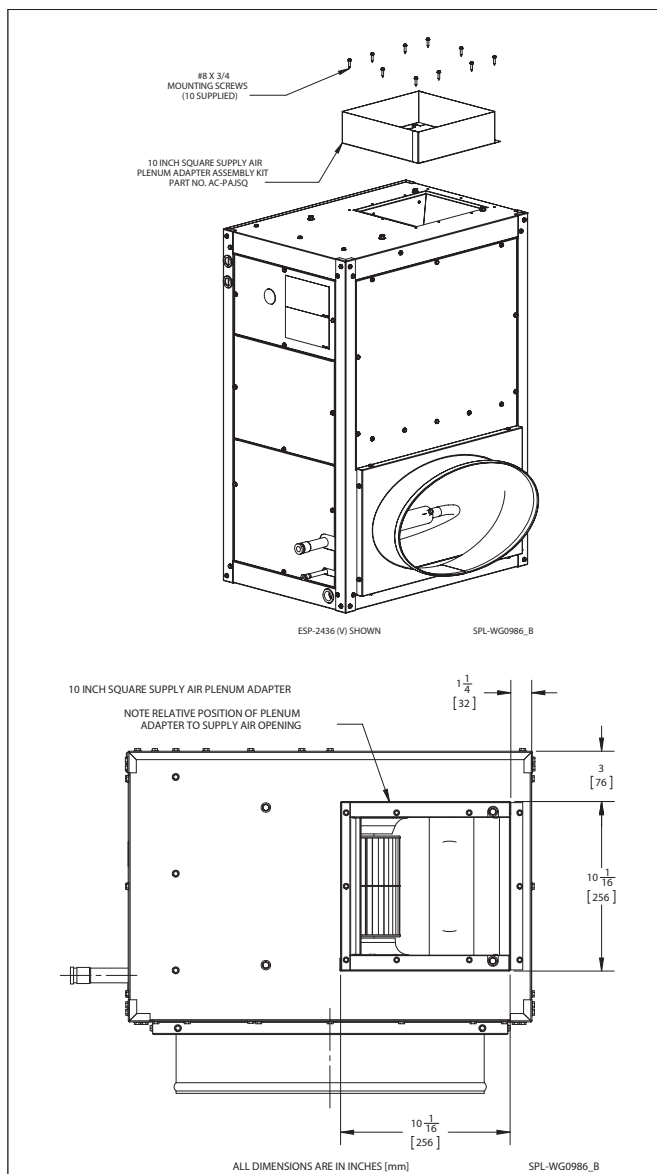
**FIGURE 2.8: RETURN AIR BOX FRAME DIMENSIONS**



**FIGURE 2.9**



**FIGURE 2.10: PLENUM ADAPTER ASSEMBLY**



## Step 4: Setting the Unit

Construct a platform for the fan coil unit, as shown in Figure 2.12. The platform can be constructed of 2 x 4 (minimum), 2 x 6, 2 x 8 and 2 x 10 lumber, as necessary to achieve proper pitch of 1/4" per foot for the condensate drain line. Figure 2.11 shows the approximate normal allowable run of condensate piping as a function of the framing lumber used for platform construction. The platform covering should be 1/2" plywood minimum.

Attach vibration isolation pads (supplied inside fan coil unit) to platform covering as shown in Figure 2.12.

Secure the platform to the joist or floor, depending on location selected for the fan coil unit. Make sure platform is level.

For locations where the fan coil unit will be suspended, suspend platform from overhead by 1/4" threaded rods.

**NOTICE: Allow room on sides for servicing.**

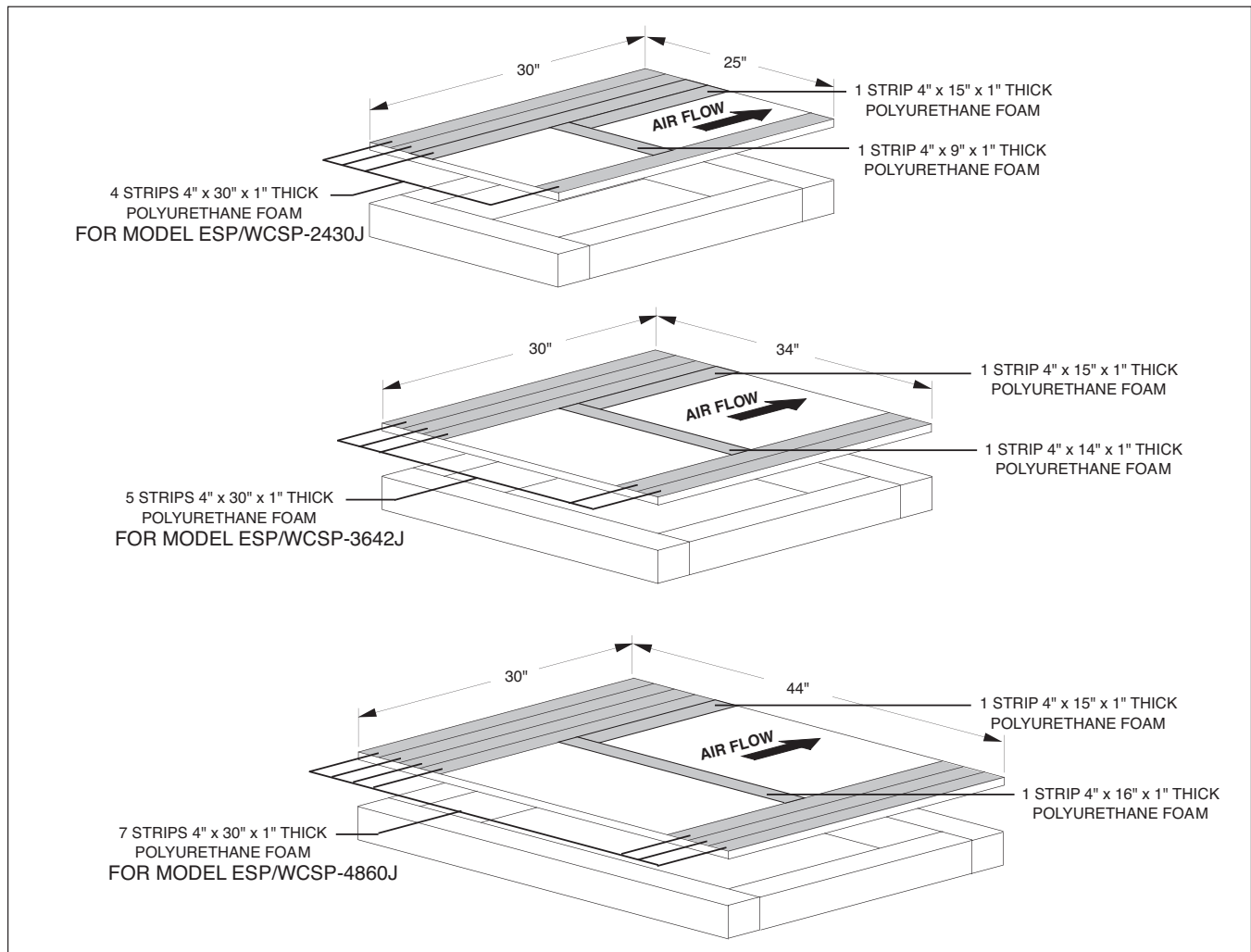
For installations with a return air box and return air duct, set fan coil unit on the platform with the elliptical opening facing in the direction of the return air box. **DO NOT** let the supply air plenum adapter support the weight of the unit.

Do not secure the unit to the platform, as the weight of the unit will hold it in position.

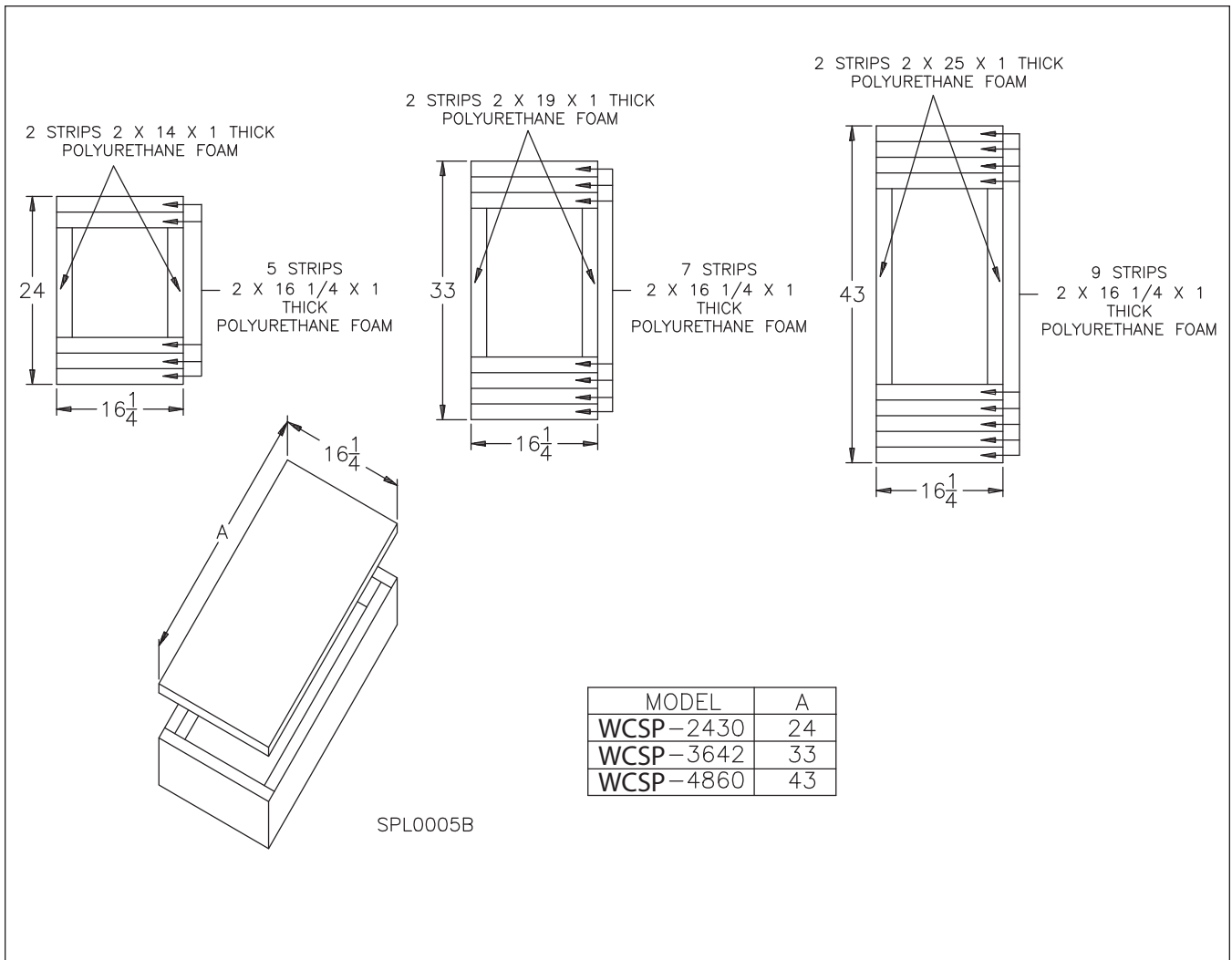
**FIGURE 2.11: CONDENSATE PIPING RUNS**

LUMBER SIZE	2 X 4	2 X 6	2 X 8	2 X 10
MAXIMUM HORIZONTAL	8'	16'	24'	32'

**FIGURE 2.12: MOUNTING PLATFORMS SHOWN WITH VIBRATION ISOLATION STRIPS**



**FIGURE 2.13: MOUNTING PLATFORMS FOR VERTICAL INSTALLATIONS**



### Step 5: Connecting Water Lines

Connect water lines from outdoor chiller unit to the fan coil unit in accordance with the chiller manufacturer's recommendations.

## Step 6: Installing the Condensate Trap & Line

**NOTICE:** It is a requirement of the International Mechanical Code (307.2.3) to install a secondary drain or an auxiliary drain pan where damage to any building components will occur as a result of overflow from the equipment drain pan or stoppage in the condensate drain piping from a cooling or an evaporator coil. Follow local code requirements.

**NOTICE:** The secondary drain connection requires field supplied components to complete installation. Follow local code requirements.

**NOTICE:** Never connect condensate line to a closed drain system.

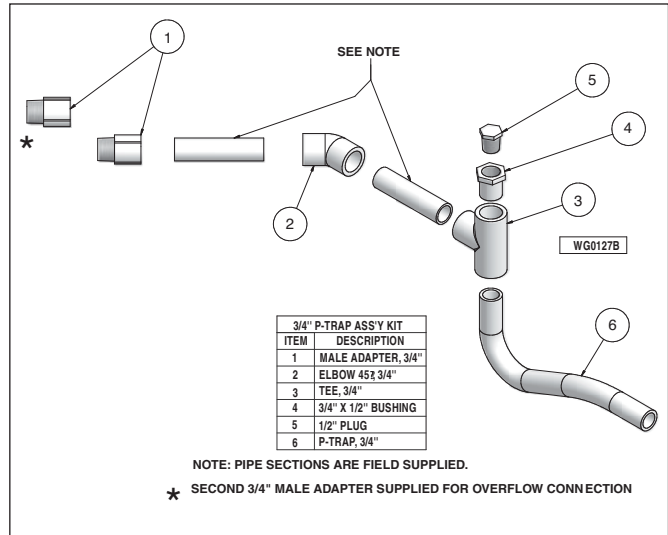
Refer to Figure 2.2 and 2.3 for primary and secondary condensate drain locations. Components for the PVC condensate trap are provided in a separate bag with fan coil unit (see Figure 2.14) and should be cemented together with PVC pipe cement.

**CAUTION** Do not use substitute trap. Do not cut off or alter trap components.

Thread male adapter (see Figure 2.14) into unit's primary condensate drain connection. Assemble and cement remaining components together. Then cement assembly to male adapter. The 45° elbow provides an offset from beneath unit suction line for access to clean-out plug.

Run a condensate line from the trap to a suitable drain that's in accordance with local codes. Make sure the line is pitched 1/4" per foot.

**FIGURE 2.14: CONDENSATE TRAP ASSEMBLY**



## Step 7: Installing Air Distribution Components

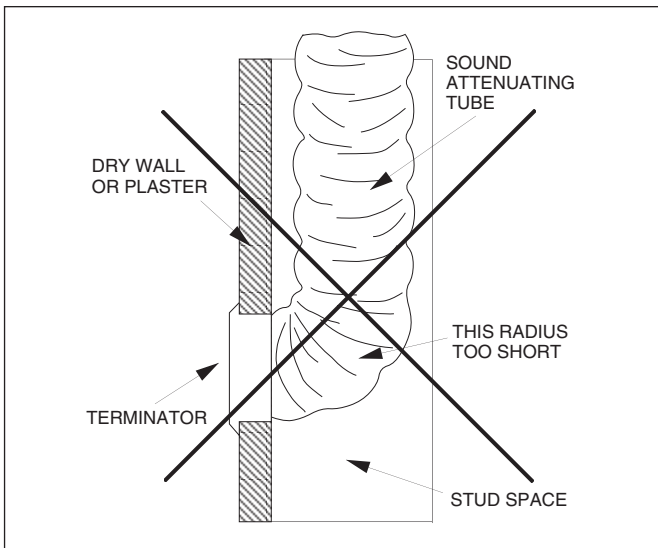
All plenum duct and supply tubing runs as well as room terminator locations must be in accordance with air distribution system requirements listed in Section 1 of this manual. Where taping of joints is required, UL181 approved tape is required.

### Plenum Duct Installation

All tees, elbows and branch runs must be a minimum of 18" from the fan coil unit or any other tee, elbow or branch run. Keep all tees and elbows to a minimum to keep system pressure drop on larger layouts to a minimum.

**NOTICE:** The following section provides with best general practices for installing SpacePak ductwork. For more details or specific duct configurations, please contact your local rep or info@spacepak.com

**FIGURE 2.15: INCORRECT TUBING INSTALLATION**



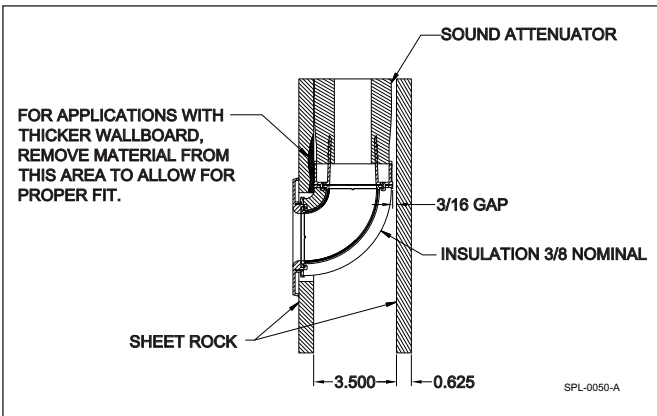
**Room Terminator & Sound Attenuating Tubing Installation**

Room terminators and pre-assembled sound attenuating tubes are provided in the Installation Kits.

**NOTICE: Do not install terminators in a wall in which a sharp bend in the sound attenuating tube is required (see Figure 2.15). The result would be unacceptable noise.**

**OPTION: Using a SpacePak Kwik Connect Wall Elbow (Model Number: AC-KCWE) addresses this condition (see Figure 2.16).**

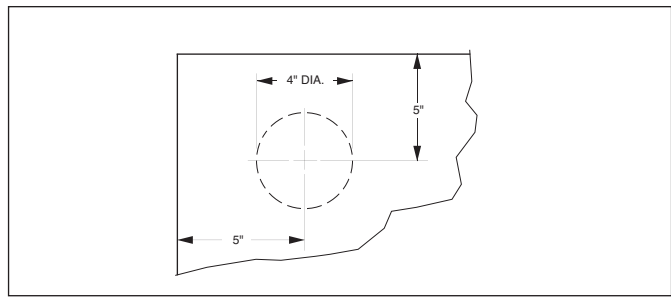
**FIGURE 2.16: INSTALLATION WITH KWIK CONNECT WALL ELBOW**



In marking location for room terminator (see Figure 2.17), the center of the terminator should be approximately 5" from the wall or, when installed in the corner of a room 5" from both walls.

After marking location, drill a 1/8" diameter hole for outlet. Verify there is at least 2" for tubing assembly clearance all around this hole by visual inspection or inserting a bent piece of wire to feel for obstructions. Adjust direction of hole as needed, to gain this 2" clearance. After all clearances have been checked, take a 4" diameter rotary-type hole saw and cut a hole, using the 1/8" diameter hole as a pilot.

**FIGURE 2.17: TERMINATOR MEASUREMENTS**



Assemble spring clips to terminator plate with screws provided in installation kit. Tighten clips until they are close to the thickness of the material they are being mounted to.

Assemble the room terminator to the sound attenuating tubing by simply fitting the two pieces together and twisting until tight (see Figure 2.16). If the terminator is to be used in a floor location, then field fabricate a small screen (1-1/2" square; 1/4 X 1/4 20-gauge galvanized wire screen) and place screen over opening on the back of the terminator prior to twisting on the kwik-connect (on the sound attenuating tube).

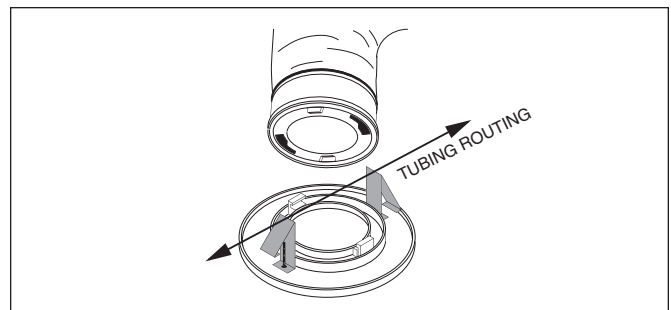
**NOTICE: Do not shorten sound attenuating tube length. The result would be unacceptable noise.**

Push the free end of the sound attenuating tube through the 4" hole until the two toggle springs on the room terminator snap into place.

Center the two spring clips on a line parallel to the direction of the tubing routing from the room terminator (see Figure 2.18). This is important since the weight of the tubing will have a tendency to cause a part of the terminator to pull away from the ceiling if the clips and tubing do not run parallel.

Then tighten the screws (attached to the terminator) until the terminator is snug against the ceiling or floor. **Do not overtighten.** For installations with floors or ceilings which are thicker than normal, longer toggle screws or special mounting plates may be required.

**FIGURE 2.18: POSITIONING ROOM TERMINATOR**



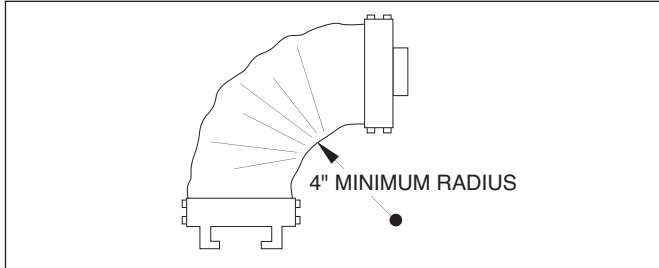


## Supply Tubing Installation

Kwik-connects and balancing orifices are provided in the Installation Kits. Plenum take-offs, gaskets and fasteners are supplied in the separate plenum take-off kit.

Avoid sharp bends in the supply tubing (as well as the sound attenuating tubing). The minimum radius bend is 4" (see Figure 2.19); however, wherever possible, hold to a larger radius.

**FIGURE 2.19: MINIMUM TUBING BEND**



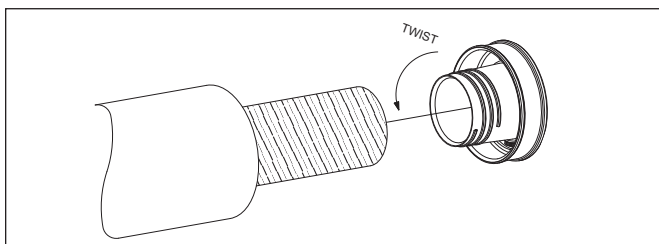
At the plenum, all supply tubing connections must be a minimum of 18" from any plenum tee, plenum elbow or the fan coil unit.

Individual supply tubing runs must be a minimum of 6-feet, even if the distance between the sound attenuating tubing and plenum is less than 6 feet.

R6 Supply tubing comes in 100-foot sections (R8 tubing comes in 75-foot sections) and may be cut to length with a knife or fine tooth hacksaw.

For each supply tubing run, estimate and cut the length of tubing that will be needed between the plenum and sound attenuating tube. At the open end of the supply tubing a kwik-connect will be installed (see Figure 2.20). First, push back the cover and the insulation exposing approximately 4" of the inner core. Fold in any tails or frays that may be present after cutting the supply tubing. Second, hand compress the corrugations until they are densely compacted 1-1/2" to 2" from the open end of the supply tube. Third, thread kwik-connect into the inner core until snug. Fourth, pull the insulation and cover forward and tuck it into the deep groove on the back side of the kwik-connect. Fifth, wrap the connection securely with UL181 approved tape.

**FIGURE 2.20: KWIK-CONNECT INSTALLATION**

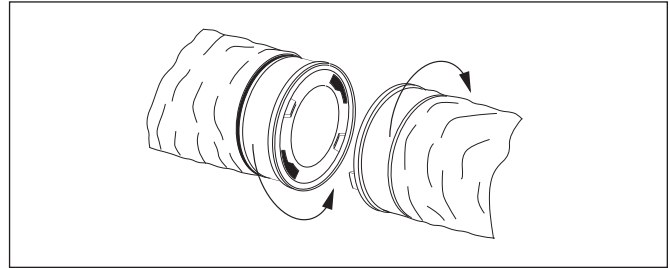


When finished, simply twist together (see Figure 2.21) the kwik-connect on the sound attenuating tube, and wrap the connection securely with tape.

After attaching the supply tubing to the sound attenuating tube, bring the open end of the tube to the plenum.

To cut a hole in the plenum, refer to duct installation instructions supplied with fan coil unit. Sheet metal duct requires a 2-1/16" hole.

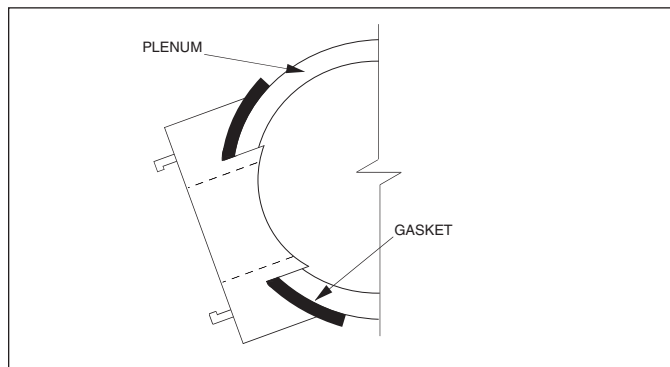
**FIGURE 2.21: CONNECTING TUBING**



Remove the hole cut-out from the plenum. Make sure there is no "flap" left inside plenum that could block hole during operation.

Place the plenum take-off gasket on the back side of the plenum take-off and insert the assembly into the hole in the plenum (see Figure 2.22).

**FIGURE 2.22: TAKE-OFF INSTALLATION**

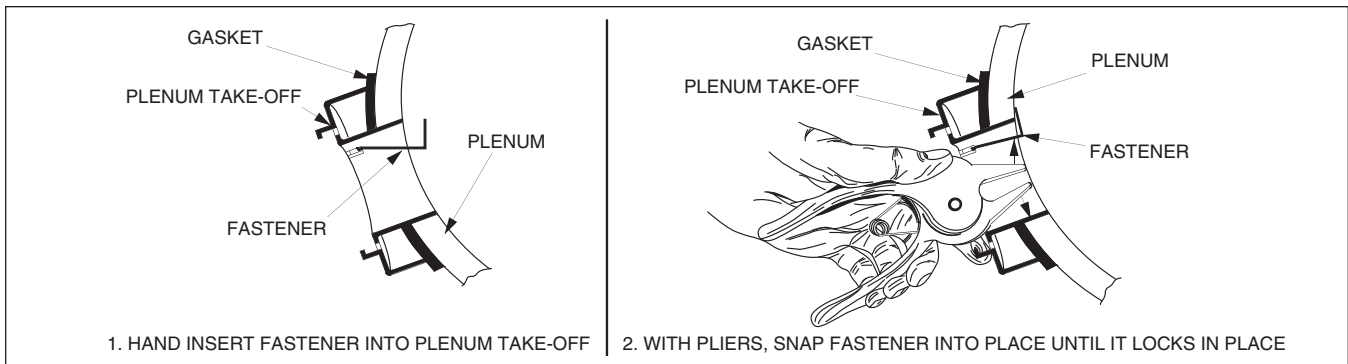


**NOTICE: Gasket must be installed to seal plenum take-off to prevent air leakage.**

Position the plenum take-off to match the curvature of the plenum duct. Hand insert the four plenum take off fasteners one at a time such that each clip reaches the interior of the duct. Using the SpacePak pliers, snap the fasteners into place until they lock in place (see Figure 2.23).

**NOTICE: All four fasteners must be installed to assure air tight fitting between plenum take-off and plenum.**

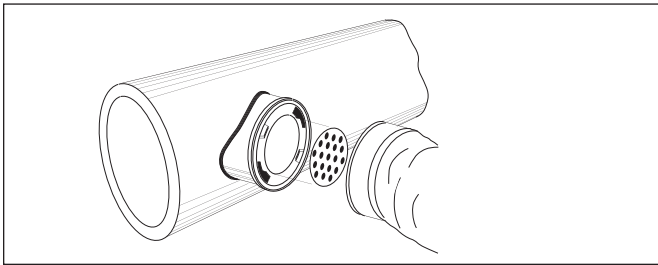
**FIGURE 2.23: PLENUM TAKE-OFF FASTENER INSTALLATION**



In accordance with your calculations as to requirements for balancing orifices, mount the orifice in the outlet of the plenum take-off (see Figure 2.24), prior to attaching the supply tubing.

Next, install a kwik-connect in the open end of the supply tubing, using the same procedures as before, and twist together kwik-connects on supply tubing and plenum take-off. Wrap connection securely with tape.

**FIGURE 2.24: ORIFICE INSTALLATION**

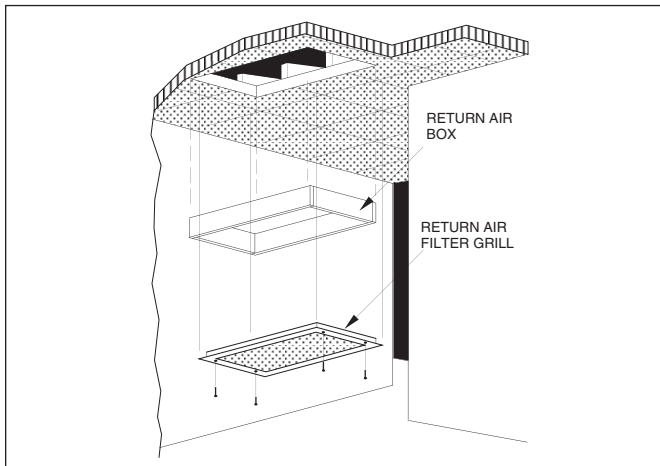


**Return Air Box & Duct Installation**

Remove the return air grill from the return air box and remove the air filter from the return air grill.

Insert the return box from below for ceiling installation (or from the front for wall installations) and fasten with four screws through holes provided on the long side of the box. (see Figure 2.25).

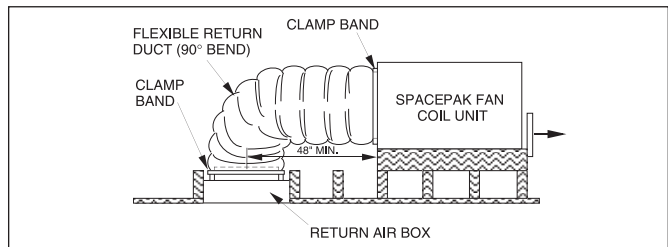
**FIGURE 2.25: RETURN AIR BOX INSTALLATION**



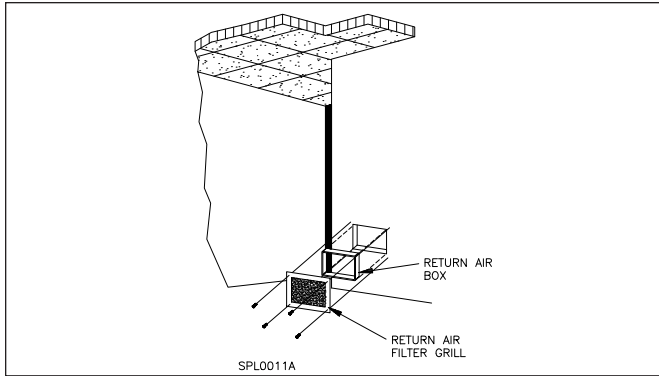
Remove the grill and the filter from the grill frame. Insert the frame into the box and mount in place with the screws provided through a hole at each corner of the frame. Finally, place the air filter into the frame and replace the grill. Turn the latches a quarter turn to lock the grill in place.

Slide a clamp band (provided with return air box) over one end of the return air duct. Place that end over the elliptical flange on the fan coil unit (see Figure 2.26). Move the clamp over the flange and tighten so the clamp holds the return air duct securely to the flange. Follow the same procedures to attach the return air duct to the return air box (see Figure 2.26).

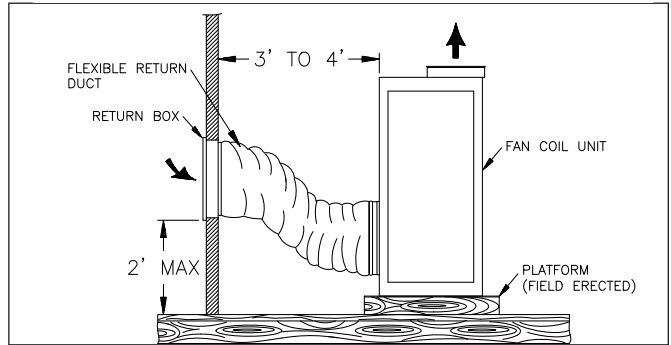
**FIGURE 2.26: RETURN AIR DUCT INSTALLATION**



**FIGURE 2.27: RETURN AIR BOX INSTALLATION**



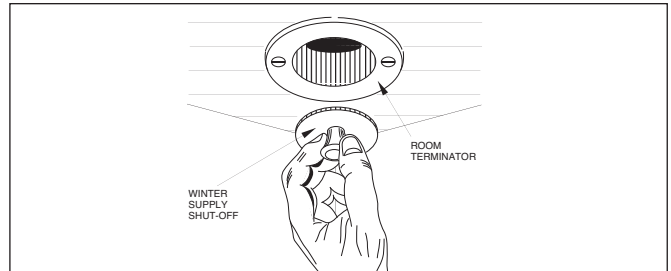
**FIGURE 2.28: TYPICAL CLOSET/UTILITY ROOM INSTALLATION**



**Winter Supply Shut-Off Installation**

Simply insert winter supply shut-offs into the room terminator openings (see Figure 2.29). Wrap the return air filter in a plastic bag and reinstall it to block the return air opening. Winter supply shut-offs prevent moisture from collecting in ductwork during winter months. Be sure to remove the plastic bag and all winter supply shut-offs before operating the system.

**FIGURE 2.29: WINTER SUPPLY SHUT-OFF**



**Step 8: B & C Series Unit Retrofits**

For retrofitting an WCSP-J series unit to an existing WCSP-B or C series, some modifications will need to be made to the current system. The necessary changes are below and the extent of the changes is dependent upon the model of the unit. (Refer to Figures 2.30/2.31/2.32)

**WCSP-2430 Retrofits**

The 7" duct can still be utilized with a transition kit (Part No. BM-6918) available from SpacePak. This kit will reduce the main plenum from 9" to 7" to adapt to the existing 7" duct.

**WCSP-3642/4860 Retrofits**

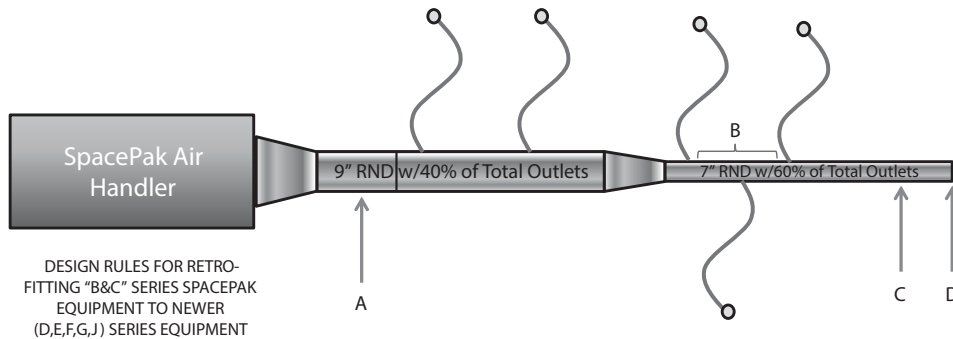
The existing plenum duct, which is typically 7", will need to be replaced with 8" X 8" duct board or field supplied 9" round duct. The return duct and return grille will also have to be replaced with the proper parts for the replacement

model. The reason for this change is the amount of air supplied by current models is 30% higher than the B & C Series models. The existing 7" duct work will reduce the air flow and cause excessive static pressures resulting in lack of performance and could possibly freeze up the coil which will result in compressor failure due to short cycling.

**NOTICE FOR ALL RETROFITS**

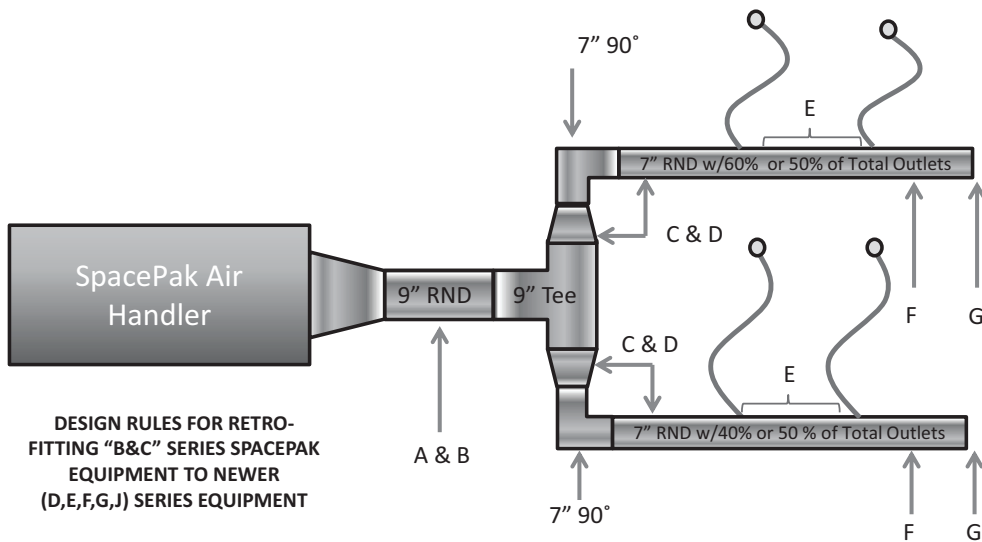
It may be necessary to add outlets to the system. The number of additional outlets will be dependent upon the external static pressure which should be measured with a manometer. This measurement should be between 1.2-1.3" WC. For more details on this test procedure and location for the test, refer to the System Start Up and Adjustment section in this installation manual. If you are unsure of your application please reach out to your local rep or info@spacepak.com.

**FIGURE 2.30: STRAIGHT DUCT OR SHOTGUN LAYOUT**



- A: No outlets in the first 18" of straight pipe coming off the Air Handler
- B: Minimum distance between outlets is 6" on center
- C: Minimum distance when placing an outlet from end cap is 12"
- D: NEVER place an outlet in the End Cap

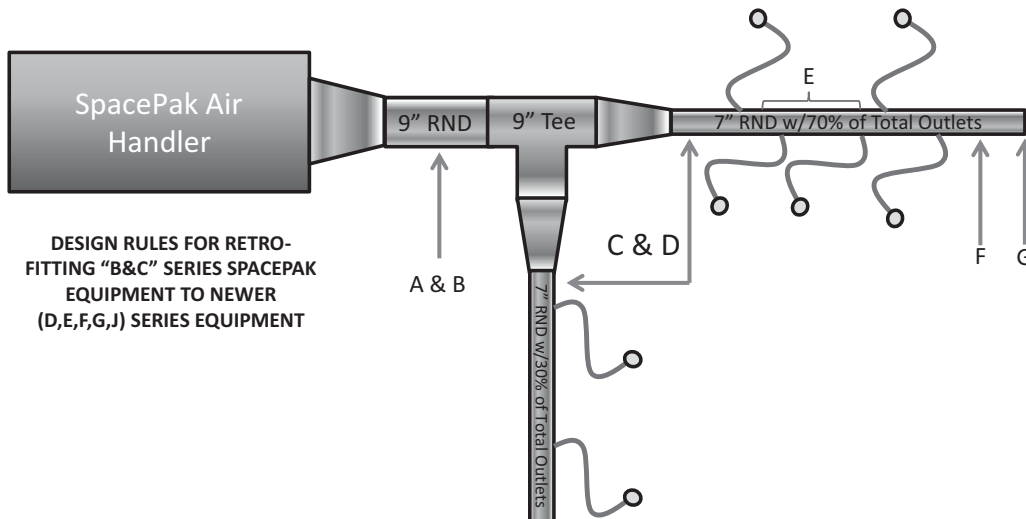
**FIGURE 2.31: HORSESHOE LAYOUT**



DESIGN RULES FOR RETRO-FITTING "B&C" SERIES SPACEPAK EQUIPMENT TO NEWER (D,E,F,G,J) SERIES EQUIPMENT

- A: Minimum distance from the air handler outlet to first tee or elbow is 18"
- B: No outlets in the first 18" of straight pipe off of the air handler
- C: Minimum distance of straight pipe after any tee or elbow is 18"
- D: Minimum distance when placing outlet after any tee or elbow is 18"
- E: Minimum distance between outlets is 6" on center
- F: Minimum distance when placing an outlet from the end cap is 12"
- G: Never place an outlet in the end cap

**FIGURE 2.32: SIDE BRANCH**



DESIGN RULES FOR RETRO-FITTING "B&C" SERIES SPACEPAK EQUIPMENT TO NEWER (D,E,F,G,J) SERIES EQUIPMENT

- A: Minimum distance from the air handler outlet to first tee or elbow is 18"
- B: No outlets in the first 18" of straight pipe off of the air handler
- C: Minimum distance of straight pipe after any tee or elbow is 18"
- D: Minimum distance when placing outlet after any tee or elbow is 18"
- E: Minimum distance between outlets is 6" on center
- F: Minimum distance when placing an outlet from the end cap is 12"
- G: Never place an outlet in the end cap

## Step 9: Wiring the Unit

**⚠ WARNING** Turn off electrical power supply before servicing. Contact with live electric components can cause shock or death.

**All electrical wiring/connections shall be performed by a licensed and certified technician and electrician. Warranty will be void if proper wiring practices are not followed.**

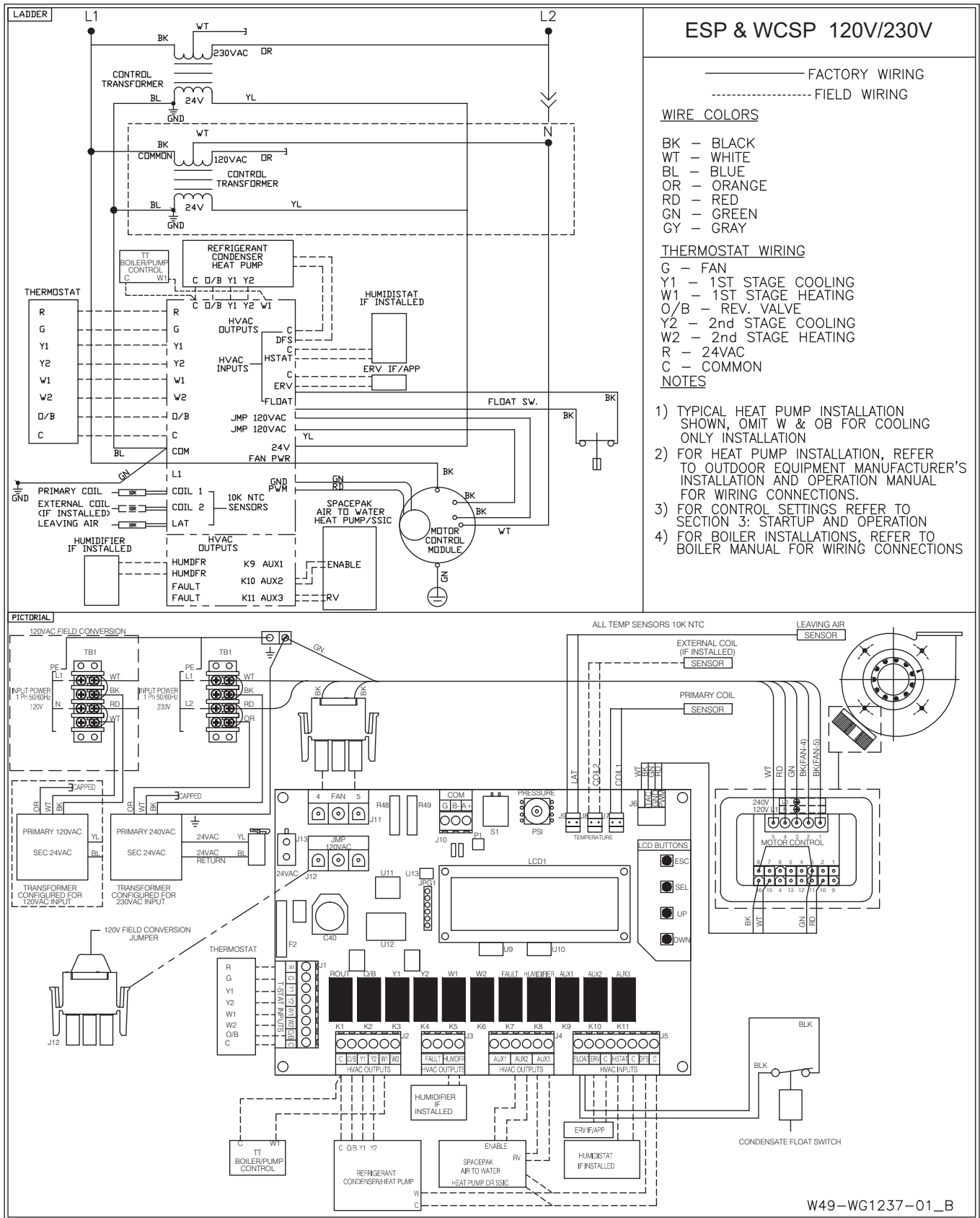
All electrical and control wiring must be installed in accordance with the codes listed in Section 1 of this manual. Standard wiring diagram is provided in Figure 2.33. Optional wiring diagram is provided in Figure 2.34. A separate 230/60/1 power supply is recommended for the unit.

**⚠ CAUTION** When sizing for proper circuit breakers and wire size to supply the air handlers, all local and national electrical codes must be followed. The MCA and MOP are provided on the nameplate of each air handler as well as in this manual for reference. Failure to follow electrical codes will result in void of warranty.

Connect power supply to Terminals L1 and L2 on the high voltage terminal block. Connect a ground wire to the equipment ground terminal located next to the high voltage terminal block.

Locate the room thermostat on a wall near the return air box. Install the selected thermostat per the thermostat manufacturer's installation instructions. Ensure the proper wiring from the thermostat to the SpacePak air handler by following the air handler diagrams found in this manual.

**FIGURE 2.33: MODEL WCS-J 230V STANDARD WIRING DIAGRAM\***



**ESP & WCSP 120V/230V**

————— FACTORY WIRING  
 - - - - - FIELD WIRING

WIRE COLORS

- BK - BLACK
- WT - WHITE
- BL - BLUE
- OR - ORANGE
- RD - RED
- GN - GREEN
- GY - GRAY

THERMOSTAT WIRING

- G - FAN
- Y1 - 1ST STAGE COOLING
- W1 - 1ST STAGE HEATING
- O/B - REV. VALVE
- Y2 - 2nd STAGE COOLING
- W2 - 2nd STAGE HEATING
- R - 24VAC
- C - COMMON

NOTES

- 1) TYPICAL HEAT PUMP INSTALLATION SHOWN, OMIT W & OB FOR COOLING ONLY INSTALLATION
- 2) FOR HEAT PUMP INSTALLATION, REFER TO OUTDOOR EQUIPMENT MANUFACTURER'S INSTALLATION AND OPERATION MANUAL FOR WIRING CONNECTIONS.
- 3) FOR CONTROL SETTINGS REFER TO SECTION 3: STARTUP AND OPERATION
- 4) FOR BOILER INSTALLATIONS, REFER TO BOILER MANUAL FOR WIRING CONNECTIONS

W49-WG1237-01\_B



## Integral Air Handler Control

The SpacePak ESP and WCSP air handlers now feature a sophisticated control platform that has the ability to control fan speed by measuring static pressure and calculating airflow (CFM), as well as heat exchanger coil temperature.

The fan control logic can be configured to maintain a constant static pressure, or constant fan speed, with individual settings that can be assigned to each of five different operating inputs; Cooling Y1, Cooling Y2, Heating W1, Heating W2, and G fan only. Each set point is adjusted separately through the onscreen interface, which is an integral component of the control board.

In each mode, the fan will gradually increase to the specific set point in order to minimize perceived airflow and duct noise. In the Cooling and Heating modes, the fan will not ramp up to the desired set point until the coil reaches the appropriate temperature. Both heating and cooling fan start set points can be adjusted through the onscreen menu following the menu tree located in this section.

The screen will also display the delivered airflow, in Cubic Feet per Minute, delivered by the air handler. **CFM calculation is an approximation based upon laboratory test conditions, and may be affected by certain system construction features such as temperature and elevation. The primary setup criteria for all Small Duct High Velocity systems should always be Duct Static Pressure. CFM and static pressure displayed on screen should be used as REFERENCE ONLY.**

All delivered airflow and static pressure, for each application, should be verified upon installation with calibrated equipment to ensure proper system operation and for troubleshooting purposes. For ESP models; The control also manages output signals to the outdoor condenser or heat pump, whether single or dual stage, as well as indoor accessories such as an ERV/HRV, Humidifier, Electric Heater or Auxiliary Hydronic Heating Coil.

For WCSP models; The control also manages output signals to the Geo or Air to Water Heat Pump, as well as indoor accessories such as an ERV/HRV, Humidifier, Electric Heater, Auxiliary Hydronic Heating Coil, or SSIC Hydronic System Interface Controller.

Refer to Section 3 for more detailed description and start-up instruction as well as the appropriate wiring diagrams located in section 2 step 9 of this manual.

All SpacePak integrated air handler control boards are configurable in the field for every model of air handler. The control will come from the factory with specific defaults (see defaults tables) and sized appropriately for that air handler. Prior to troubleshooting, the air handler model should be verified on the board as the board reacts differently based on the model of the air handler. Follow the menu tree and steps in the following section to verify proper unit commissioning.

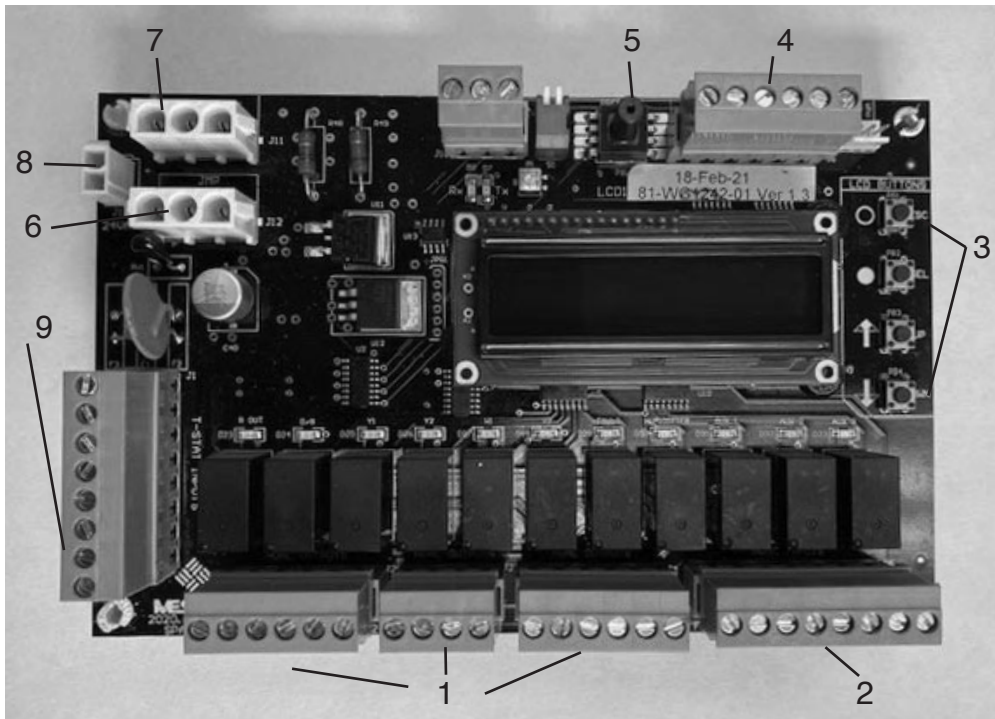
Upon startup of every J+ air handler and control board, the initializing screen will display the firmware uploaded for that unit. The following section will describe features and functionality that may or may not be applicable to the firmware on the unit. When troubleshooting or commissioning please verify your features match the associated firmware on the unit.

If you need assistance in commissioning your SpacePak air handler control board, please reach out to tech support at [TechnicalService@SpacePak.com](mailto:TechnicalService@SpacePak.com)



# SECTION 3: START-UP & COMMISSIONING

## Controls Overview/Features/Setpoints



J+ Control Board Navigation

**\*IMPORTANT\*** When making selections the user **MUST** press the "SEL" key to save the desired selection. If the "SEL" key is not pressed the control will revert to the previous setpoint/selection.

HVAC Outputs (1)	C	Common
	O/B	Reversing Valve
	Y1	1st Stage Cooling
	Y2	2nd Stage Cooling
	W1	1st Stage Heating
	W2	2nd Stage Heating
	FAULT	Closes on Fault
	HUMDFR	Closes on Call
	AUX 1	Energized on heat, cool, or heat/cool (configured in field)
	AUX 2	ESP Units- Energized in cooling; WCS Units- Closed contacts during heat or cool call depending on configuration chosen in field.
HVAC Inputs (2)	AUX 3	ESP Units- Energized in heating; WCS Units- Energize on reversing valve for heat pumps
	FLOAT	Float Switch (factory installed)
	ERV	24v input from ERV
	C	ERV Common
	HSTAT	24v input from Humidistat
	C	Humidistat Common
LCD Buttons (3)	DFS	24v input from Defrost on outdoor Heat Pump
	C	Defrost Common
	ESC	Escape
	SEL	Select
Temperature (4)	UP	Arrow up
	DOWN	Arrow down
	LAT	Leaving Air Temperature
Pressure (5)	COIL2	Auxiliary Heating Coil
	COIL1	Primary Evaporator Coil
JMP (6)	PS1	Delivered Air
FAN (7)	J12	120V Jumper. If field installed allows for 120V operation. (Shipped loose)
	4	Fan Power Harness
24VAC (8)	5	Fan Power Harness
	J13	24 from transformer
T-Stat Inputs (9)	R	24V
	G	Fan
	Y1	1st Stage Cooling
	Y2	2nd Stage Cooling
	W1	1st Stage Heating
	W2	2nd Stage Heating
	O/B	Reversing Valve
	C	Common

## RUN SCREEN

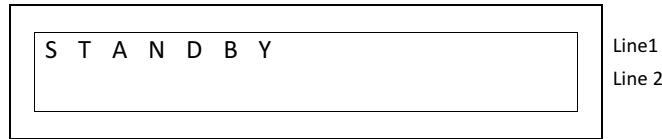
There are 5 run screens that show the current status of the unit. Pressing the UP or DOWN buttons will cycle through the 5 screens.

### Run Screen #1.

**Line 1** shows the status of the unit: STANDBY, HEATING, COOLING, or FAN.

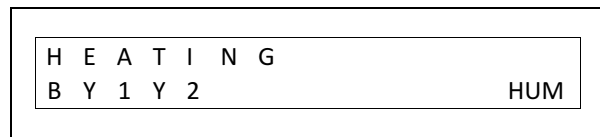
**Line 2** shows the HVAC inputs currently present: O/B, Y1, Y2, W1, W2, G, HUMIDIFIER [HUM] and ERV. Line 2 will also display faults, warnings, and errors. Fault, warnings, and configuration errors are found in the FAULT section of this manual.

Examples:



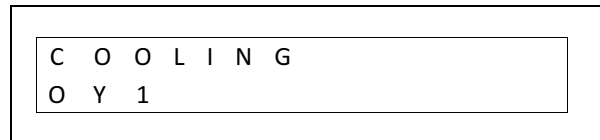
Line 1: Heating call

Line 2: B, Y1 and Y2 HVAC inputs are energized and the humidifier is running.



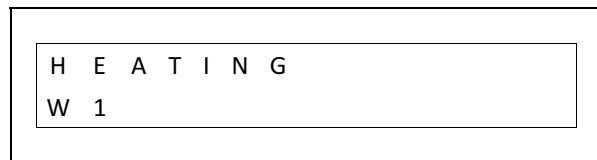
Line 1: Cooling call

Line 2: O and Y1 HVAC inputs are energized.



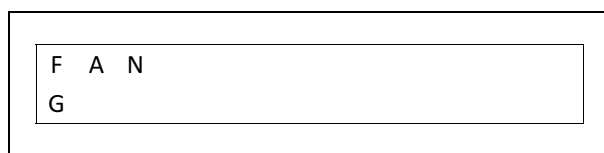
Line 1: Heating call

Line 2: W1 HVAC input is energized



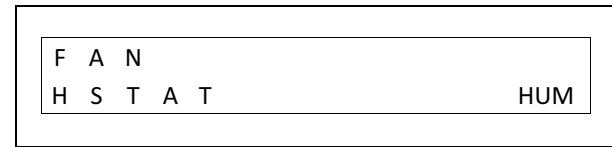
Line 1: Fan is running

Line 2: G HVAC input is energized



Line 1: FAN, and Humidifier are running

Line 2: Humidifier [HSTAT] HVAC input is energized



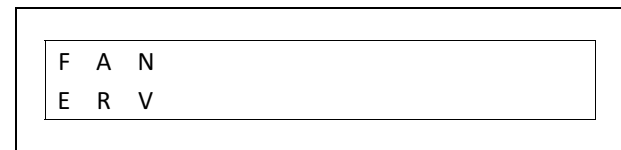
Line 1: FAN and Humidifier are running

Line 2: G, and Humidifier [HSTAT] HVAC inputs are energized



Line 1: FAN, and ERV are running

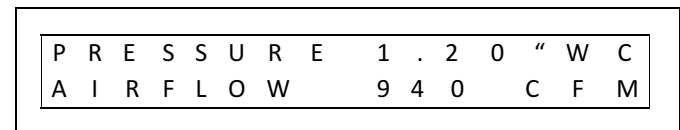
Line 2: ERV input is energized



### Run Screen #2.

Line 1 displays the measured static pressure in Inches of water column ["WC]

Line 2 show the Airflow in cubic feet per minute [CFM]

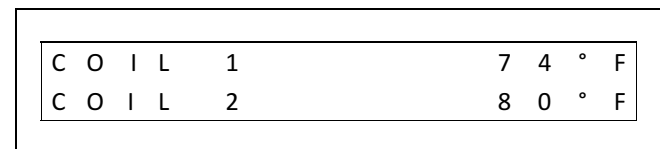


### Run Screen #3, and #4.

Run screen #3 and #4 display coil temperature readings and the leaving air temperature. If a temperature sensor is not installed "NONE" will be displayed, if a temperate sensor is faulted in a shorted or open condition, SHORTED or OPEN will be displayed.

Examples:

### Run Screen #3.



Note: If the Secondary Hot Water Coil [SEC HW COIL] is disabled, line 2 will be blank.

C	O	I	L	1				O	P	E	N
C	O	I	L	2				N	O	N	E

**Run Screen #4.**

L	A	T						7	4	°	F	
F	A	N	S	P	E	E	D	%		1	0	0

**Run Screen #5.**

Line 1 shows the Model and Size.  
 Line 2 shows the Unit type: Reverse Cycle Chiller, Heat Pump, Cooling or Heating mode only, as well as the Reversing valve setting, and the secondary heating water coil if installed.

Examples:

Unit Configuration: ESP model, size 3642J, horizontal [H] unit, configured as heat pump with its reversing valve set to energize in cooling and a secondary hot water coil installed

M	O	D	E	L	E	S	P	3	6	4	2	JH
H	P		O		H	W	C					

Unit Configuration: ESP model, size 2430J, vertical [V] unit, configured as a heat pump with its reversing valve set to energize in heating and a secondary hot water coil installed

M	O	D	E	L	E	S	P	2	4	3	0	JV
H	P		B		H	W	C					

Unit Configuration: WCS model, size 3642J horizontal [H] unit, configured as a reverse cycle chiller with its reversing valve set to energize in heating

M	O	D	E	L	W	C	S	3	6	4	2	JH
R	C	C		O								

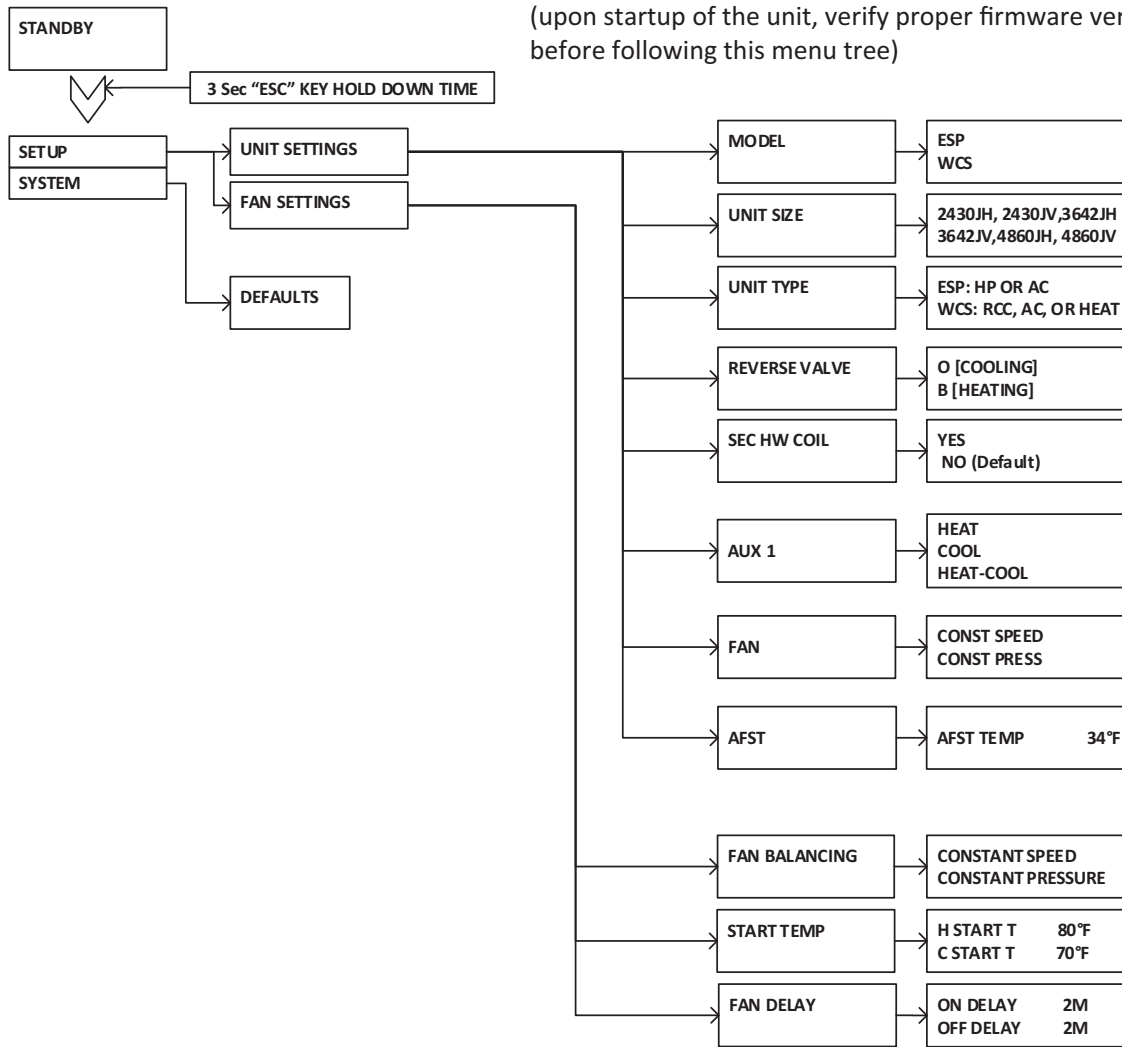
The following menu trees are accessible within the advanced control. They can be accessed by holding the "ESC" key down for 3 seconds. Within these menu trees are configurable settings for each application and unit type. Please refer to the proper menu tree per the firmware version on the control board prior to making any changes or adjustments to the unit configuration. Failure to do so can prevent proper operation and performance of the system. The defaults menu is how each unit is configured from the factory. By using the menu trees, these defaults can be adjusted.

## DEFAULTS

ITEM DESCRIPTION	DEFAULT	MAX	MIN
UNIT MODEL*	PER UNIT PURCHASED		
UNIT SIZE*	PER UNIT PURCHASED		
UNIT TYPE	HP		
REVERSING VALVE	O		
SEC HW COIL	NO		
AUX 1	HEAT		
FAN	CONSTANT PRESSURE		
ANTI FROST TEMPERATURE	34	50°F	34°F
SPEED Y1	50%	100%	5%
SPEED Y2	50%	100%	5%
SPEED Y12	50%	100%	5%
SPEED W1	50%	100%	5%
SPEED W2	50%	100%	5%
SPEED W12	50%	100%	5%
SPEED G	50%	100%	5%
SPEED HUMIDIFIER	50%	100%	5%
SPEED ERV	50%	100%	5%
SPEED DEFROST [DFS]	30%	100%	5%
STATIC PRESSURE Y1	1.2 "WC	2.5 "WC	0.5 "WC
STATIC PRESSURE Y2	1.2 "WC	2.5 "WC	0.5 "WC
STATIC PRESSURE Y12	1.2 "WC	2.5 "WC	0.5 "WC
STATIC PRESSURE W1	1.2 "WC	2.5 "WC	0.5 "WC
STATIC PRESSURE W2	1.2 "WC	2.5 "WC	0.5 "WC
STATIC PRESSURE W12	1.2 "WC	2.5 "WC	0.5 "WC
STATIC PRESSURE G	1.2 "WC	2.5 "WC	0.5 "WC
STATIC PRESSURE HUMIDIFIER	1.2 "WC	2.5 "WC	0.5 "WC
STATIC PRESSURE ERV	1.2 "WC	2.5 "WC	0.5 "WC
STATIC PRESSURE DEFROST [DFS]	0.7 "WC	2.5 "WC	0.5 "WC
HEATING START TEMPERATURE	80	120°F	60°F
COOLING START TEMPERATURE	70	80°F	50°F
FAN ON DELAY	2 MINUTES	5 MIN	1 MIN
FAN OFF DELAY	1 MINUTES	5 MIN	0 MIN

\*The unit model and size will be set from the factory specific to that unit. If it is a replacement board, the default model will be "ESP" and the default size will be 2430JH. Please properly commission all replacement boards specific to that application

Firmware versions 1.4 and lower  
(upon startup of the unit, verify proper firmware version  
before following this menu tree)



FAN BALANCING – CONSTANT SPEED

Y1:	SPEED%
Y2:	SPEED%
Y12:	SPEED%
W1:	SPEED%
W2:	SPEED%
W12:	SPEED%
G:	SPEED%
HDRF:	SPEED%
ERV:	SPEED%
DFS:	SPEED%

➤

Y1% PRESS	CFM
50	0.4 350
Y2% PRESS	CFM
50	0.4 350
Y12% PRESS	CFM
50	0.4 350
W1% PRESS	CFM
50	0.4 350
W2% PRESS	CFM
50	0.4 350
W12% PRESS	CFM
50	0.4 350
G% PRESS	CFM
50	0.4 350
HDRF% PRESS	CFM
50	0.4 350
ERV% PRESS	CFM
50	0.4 350
DFS% PRESS	CFM
50	0.4 350

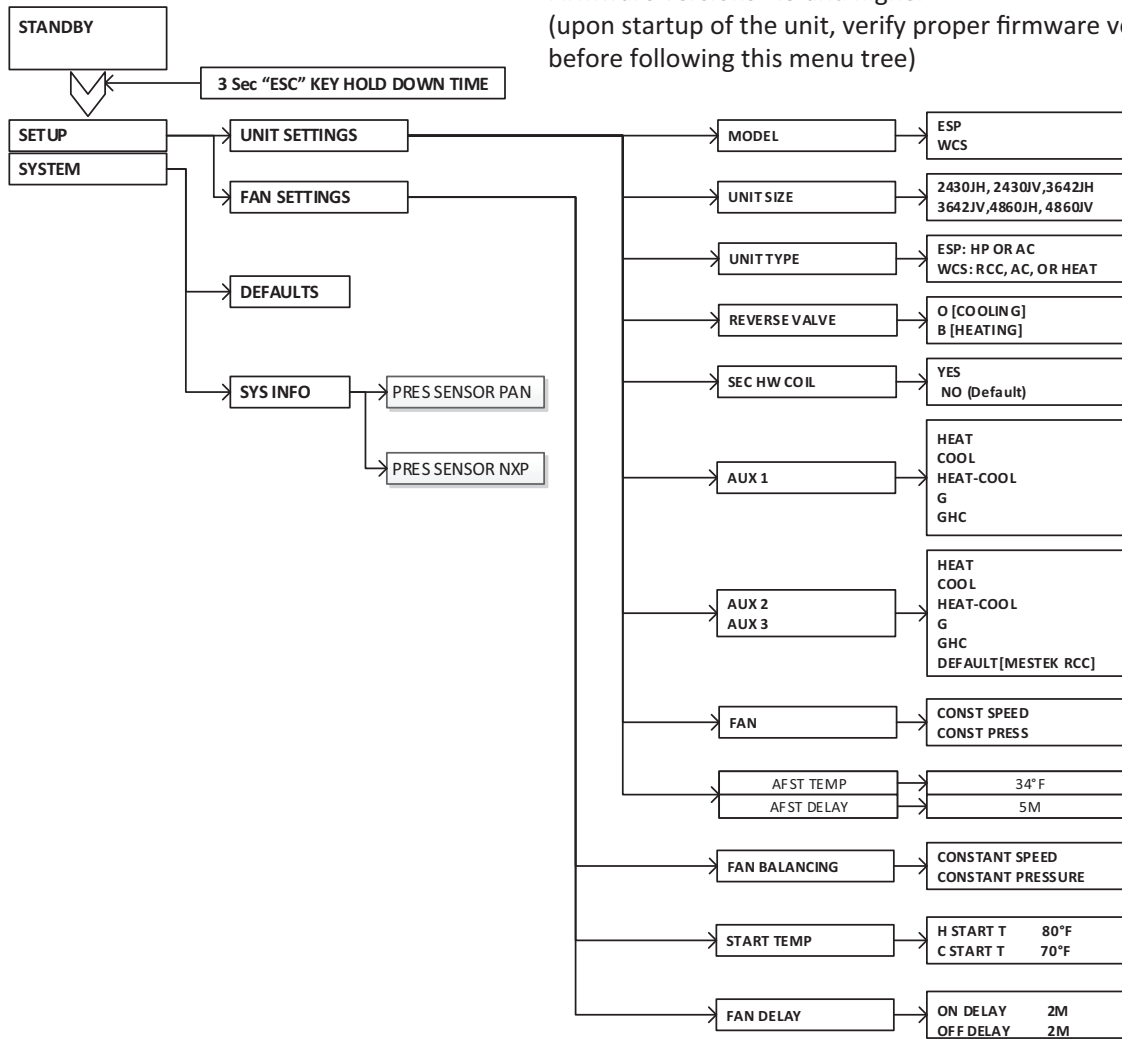
FAN BALANCING – CONSTANT PRESSURE

Y1:	ST PRESS
Y2:	ST PRESS
Y12:	ST PRESS
W1:	ST PRESS
W2:	ST PRESS
W12:	ST PRESS
G:	ST PRESS
HDRF:	ST PRESS
ERV:	ST PRESS
DFS:	ST PRESS

➤

Y1 SP PRESS	CFM
1.2	0.51 350
Y2% SP PRESS	CFM
1.2	0.51 350
Y12% SP PRESS	CFM
1.2	0.51 350
W1% SP PRESS	CFM
1.2	0.51 350
W2% SP PRESS	CFM
1.2	0.51 350
W12% SP PRESS	CFM
1.2	0.51 350
G% SP PRESS	CFM
1.2	0.51 350
HDRF% SP PRESS	CFM
1.2	0.51 350
ERV% SP PRESS	CFM
1.2	0.51 350
DFS% SP PRESS	CFM
1.2	0.51 350

Firmware versions 1.5 and higher  
(upon startup of the unit, verify proper firmware version before following this menu tree)



FAN BALANCING – CONSTANT SPEED

Y1:	SPEED%	Y1% PRESS	CFM
Y2:	SPEED%	50 0.4	350
Y12:	SPEED%	Y2% PRESS	CFM
W1:	SPEED%	50 0.4	350
W2:	SPEED%	Y12% PRESS	CFM
W12:	SPEED%	50 0.4	350
G:	SPEED%	W1% PRESS	CFM
HDRF:	SPEED%	50 0.4	350
ERV:	SPEED%	W2% PRESS	CFM
DFS:	SPEED%	50 0.4	350
		W12% PRESS	CFM
		50 0.4	350
		G% PRESS	CFM
		50 0.4	350
		HDRF% PRESS	CFM
		50 0.4	350
		ERV% PRESS	CFM
		50 0.4	350
		DFS% PRESS	CFM
		50 0.4	350

FAN BALANCING – CONSTANT PRESSURE

Y1:	ST PRESS	Y1 SP PRESS	CFM
Y2:	ST PRESS	1.2 0.51	350
Y12:	ST PRESS	Y2% SP PRESS	CFM
W1:	ST PRESS	1.2 0.51	350
W2:	ST PRESS	Y12% SP PRESS	CFM
W12:	ST PRESS	1.2 0.51	350
G:	ST PRESS	W1% SP PRESS	CFM
HDRF:	ST PRESS	1.2 0.51	350
ERV:	ST PRESS	W2% SP PRESS	CFM
DFS:	ST PRESS	1.2 0.51	350
		W12% SP PRESS	CFM
		1.2 0.51	350
		G% SP PRESS	CFM
		1.2 0.51	350
		HDRF% SP PRESS	CFM
		1.2 0.51	350
		ERV% SP PRESS	CFM
		1.2 0.51	350
		DFS% SP PRESS	CFM
		1.2 0.51	350

## Commissioning and Adjusting Parameters

(Note: some menus will not be available depending on firmware version. Verify proper firmware version upon start up screen)

Press the ESC key for 3 seconds to enter the control menu system.

SETUP	UNIT SETTINGS
	FAN SETTINGS
	TIMERS
SYSTEM	DEFAULTS

### SETUP MENU

The SETUP menu has 3 submenus: UNIT SETTINGS, FAN SETTINGS, and TIMERS.

#### 1. UNIT SETTINGS

The UNIT SETTINGS menu consists of 8 submenus: MODEL, UNIT SIZE, UNIT TYPE, Reversing valve [REVERSE VALVE] settings, Secondary Hot Water Coil [SEC HW COIL], Auxiliary Relay 1[AUX 1], [FAN] CONSTANT SPEED or CONSTANT PRESSURE driven operation, and anti-frost temperature setting [AFST TEMP]. For units with firmware versions 1.5 or higher, there is a 9th submenu option. [AFST DELAY].

UNIT SETTINGS	MODEL
	UNIT SIZE
	UNIT TYPE
	REVERSE VALVE
	SEC HW COIL
	AUX 1
	FAN
	AFST TEMP

- 1.1 MODEL:** This menu will allow you to select the model of the unit: ESP or WCSP.
- 1.2 UNIT SIZE:** There are 6 unit sizes options: 2430H/V, 3642H/V, and 4860H/V.
- 1.3 UNIT TYPE:** An ESP model can be configured as refrigerant heat pump by selecting [HP], or as cooling only mode available [AC] unit. A WCSP mode can be configured as a Reverse cycle chiller [RCC], or as a cooling only [AC] unit or as a heating only mode [HEAT] unit.

Note: These selections should only be changed by a qualified installer and should be verified for the installation.

Note: The unit model, and size will be configured specific to the purchased unit from the factory.

For ESP units:

UNIT TYPE	HP
	AC

For WCSP units:

UNIT TYPE	RCC
	AC
	HEAT

- 1.4 REVERSE VALVE:** The Reversing Valve [REVERSE VALVE] can be set to O [energized in cooling] or B [energized in heating]

REVERSE VALVE	O
	B

- 1.5 SEC HW COIL:** The Secondary Hot Water Coil menu [SEC HW COIL] allows you to add a secondary heating water coil as an optional item.

SEC HW COIL	NO
	YES

- 1.6 AUX 1:** The Auxiliary 1 Relay [AUX 1] can be set to close its contacts only during a heating call, only during a cooling call only or on both heating and cooling calls.

AUX 1	HEAT
	COOL
	HEAT-COOL

**AUX 1, 2, 3:** In units equipped with firmware 1.6 or higher, the auxiliary relays (AUX 1, 2, 3) can be set to close its contacts during a heating (heat) call only, cooling call (cool), heating and cooling call (Heat-Cool), a fan only call (G) or fan only, heating and cooling calls (GHC). For units equipped with firmware 1.5 or lower, the Auxiliary 1 relay (AUX 1) can be set to close on heating only (heat), cooling only (cool) or heating and cooling (heat-cool). The Aux2 terminal will always be energized during any cooling call and the Aux3 terminal will always be energized in a heating call. In a unit that is commissioned for WCSP; The Aux2 and 3 terminals are designed to work with the Spacepak Air to Water Heat pump family of products. Aux2 will be wired to the "remote on/off" terminals located in the air to water heat pump electrical compartment and Aux3 will be wired to the "Heat/Cool" terminals of the air to water heat pump. Refer to your specific air to water heat pump for the exact terminal numbers, wiring locations and follow the recommended piping practices detailed in the manual for the specific air to water heat pump.



- 1.7 Fan Speed:** The fan can be run at either a constant speed or a constant static pressure.

FAN	CONST SPEED
	CONST PRESS

When Constant Speed is selected a different speed % can be selected for each input. (Y1, Y2, W1, W2, or G). The fan will run at the set speed % for the active input. This setting can be from 5% - 100%

When Constant Pressure is selected a different static pressure setpoint can be selected for each input. (Y1, Y2, W1, W2 or G). The fan will vary its speed to maintain the static pressure target of the active input.

See section 2, FAN SETTINGS, for information on setting the speed % or static pressure setpoints.

### 1.8. Anti-Frost protection temperature setting:

The Anti-Frost Protection Temperature setting [AFST TEMP] controls the integrated Anti-frost feature. The default setting is 34°F, and is adjustable up to 50°F. The temperature of the primary coil is constantly monitored. If the coil temperature drops below the Anti-Frost Protection Temperature setting the Anti-frost feature will be enabled, the fan will continue run at the called for speed, but all HVAC output will be disabled. The feature will be disabled once the primary coil temperature rises 10°F above this setting. For units that have firmware 1.6 or greater (see section on "how to check firmware level") The HVAC outputs will remain off once the primary coil reaches 20° above setpoint AND a 2 minute time delay has expired. This will prevent short cycling of the outdoor unit. The time delay and degrees above setpoint are field adjustable. Please refer to the menu tree in this manual.

AFST TEMP	34°F
-----------	------

## 2. FAN SETTINGS

The FAN SETTINGS menu consists of 3 sub menus: FAN BALANCING, START TEMP, and FAN DELAY

FAN SETTINGS	FAN BALANCING
	START TEMP
	FAN DELAY

**2.1 FAN BALANCING:** The FAN MODE setting will determine the appearance of the FAN BALANCING menu. If CONSTANT SPEED has been selected, the SPEED% setting can be adjusted for each input.

FAN:CONST SPEED%	Y1:	SPEED%	Y1%	PRESS	CFM
			50	0.4	350
	Y2:	SPEED%	Y2%	PRESS	CFM
			50	0.4	350
	Y12:	SPEED%	Y12%	PRESS	CFM
			50	0.4	350
	W1:	SPEED%	W1%	PRESS	CFM
			50	0.4	350
	W2:	SPEED%	W2%	PRESS	CFM
			50	0.4	350
	W12:	SPEED%	W12%	PRESS	CFM
			50	0.4	350
	G:	SPEED%	G%	PRESS	CFM
			50	0.4	350
	HUM:	SPEED%	HUM%	PRESS	CFM
			50	0.4	350
	ERV:	SPEED%	ERV%	PRESS	CFM
			50	0.4	350
	DFS:	SPEED%	DFS%	PRESS	CFM
			50	0.4	350

For example: If FAN: CONSTANT SPEED has been selected, then selecting "Y1: SPEED%" will display:

Y1%	PRESS	CFM
50	0.4	350

The default speed value is 50%. Line 1 displays the units, and line 2 shows the real time value of the parameters. Selecting Y1% will set the cursor at line 2 indicating real time adjustment is active. UP and Down clicks will change Y1% increasing the fan speed value up to 100% or decreasing it down to 5%. The Pressure and CFM values are constantly being updated to provide feedback to the fan speed changes. You must hit SEL to save the desired setpoint.

FAN:CONST PRESS	Y1:	ST PRESS	Y1 SP	PRES	CFM
			1.2	0.39	350
	Y2:	ST PRESS	Y2 SP	PRES	CFM
			1.2	0.39	350
	Y12:	ST PRESS	Y12 SP	PRES	CFM
			1.2	0.39	350
	W1:	ST PRESS	W1 SP	PRES	CFM
			1.2	0.39	350
	W2:	ST PRESS	W2 SP	PRES	CFM
			1.2	0.39	350
	W12:	ST PRESS	W12 SP	PRES	CFM
			1.2	0.39	350
	G:	ST PRESS	G SP	PRES	CFM
			1.2	0.39	350
	HUM:	ST PRESS	HUM SP	PRES	CFM
			1.2	0.39	350
	ERV:	ST PRESS	ERV SP	PRES	CFM
			1.2	0.39	350
	DFS:	ST PRESS	HRV SP	PRES	CFM
			1.2	0.39	350

If CONSTANT PRESSURE has been selected the static pressure setpoint can be adjusted for each input. The user will adjust the fan speed by pressing "select" when the cursor is above the "SP". Then the target Static Pressure ("SP") can be adjusted up or down using the up and down buttons. The fan will respond in real time during the adjustment. Once the proper static pressure has been established, the user must press "select" to save the setting. If select is not pressed, the unit will revert to its previous set point.

For example: If FAN: CONSTANT PRESSURE has been selected, selecting "Y1: ST PRESS" will display:

Y1 SP	PRES	CFM
1.2	0.39	350

The default pressure setpoint 1.2" WC. Line 1 shows the units. Line 2 shows the real time value of the parameters. Selecting Y1 will set the cursor to line 2, indicating real time adjustment is active. UP and Down clicks will change the static pressure setpoint, either increasing the value to up to 2.5" WC or decreasing it down to 0.5" WC. The fan speed will vary to maintain the selected static pressure setpoint. You must hit SEL to save the desired set-point.



**2.2 FAN START TEMP:** The temperature of the heating/cooling coils is constantly being monitored. When a call for heating or cooling is received the fan will not start until the coil is at the appropriate temperature (note: for firmware versions of 1.7 or greater, if the air handler is receiving a fan only call prior to the call for heat or cool, the fan will run and will speed up or down to the appropriate thermostat input's speed). This assures the coil is at the correct temperature to avoid initially delivering warm air for a cooling call or cool air for a heating call. The Fan Start Temperature [**START TEMP**] menu allows the target coil temperature to be adjusted. The default target temperature for heating is 80°F and the default target temperature for cooling is 70°F.

START TEMP	H START T	80°F
	C START T	70°F

**2.3 FAN DELAY:** The FAN DELAY menu contains 2 settings: ON DELAY and OFF DELAY.

FAN DELAY	ON DELAY	2 m
	OFF DELAY	1 m

The FAN ON DELAY is only used if a coil sensor is in fault. If the J+ board recognizes a coil temperature sensor is not installed or has faulted the FAN ON DELAY will be used to delay the fan from coming on to allow the coil time to get to the target temperature.

The FAN OFF DELAY is always used to allow the fan to optionally run for a time after a demand has been satisfied allowing time to offload the coil of any excess heat that may still be present.

## SYSTEM MENU

The System menu consists of two items; Defaults and Cal pressure.

SYSTEM	DEFAULTS
--------	----------

The DEFAULTS menu allows all settings to be returned to factory default values indicated in Defaults Section. UNIT MODEL and UNIT SIZE are not changed when loading factory defaults.

## FAULTS AND WARNINGS:

The integrated control board is equipped to identify common faults and potential warnings during the operation of the air handlers. See below table for troubleshooting details on faults and warnings. When a fault or warning is present the screen will present the associated error on the screen on Line 2 as shown in the example below.



**Faults and Warnings Explained** (for troubleshooting refer to troubleshooting table)

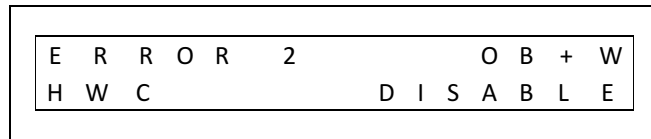
**FLOAT SW FAULT-** The primary drain pan float switch has faulted. A call to the outdoor unit will not be allowed. This is a hard lockout that requires a power cycle to reset.

**ANTIFROST SW FAULT-** The anti-frost sensor has measured a temperature lower than the setpoint (default of 34°F can be used adjusted by using the menu tree above). For units with firmware 1.4 or less, the unit will auto reset once the temperature of the coil is 6°F

## ERRORS:

### Configuration - Wiring Errors.

The J+ Control is able to recognize wiring and configuration errors. If conflicting inputs are received, the control will always prioritize heating over cooling an error message will be displayed, but the unit will continue to operate.



Based on the unit configuration the following errors can be recognized.

### Unit Configuration: HP/ RCC

#### RV = O [REVERSE VALVE ON COOLING]

For Heating Mode: Expected inputs: Y's, Y's+W's.

For Cooling Mode: Expected inputs: Y's+OB.

#### RV = B [REVERSE VALVE ON HEATING]

For Heating Mode: Expected inputs: Y's+OB, Y's+OB+W's

For Cooling Mode: Expected inputs: Y's.

Detected inputs; W's+OB or OB

#### ERRORS:

Error 1: Unexpected OB, Configuration error. Wiring error.

Error 2: Unexpected W's+OB, Configuration error. Wiring error.

above the setpoint. For units with firmware 1.5 or greater, the unit will reset after the coil 1 temperature is 20° above set point AND a 2 minute time delay to prevent short cycling of the outdoor unit. Please note that the time delay and temp differential are adjustable in the menu tree.

**LOW PRESS FAULT-** The pressure transducer (located on the control board) is reading less than .1" when the fan is running. During this fault, the unit will not display a calculated CFM or a static pressure reading. The blower will continue to run and the unit operation will change (automatically) from constant pressure to constant speed.

**TRANSDUCER FAULT-** The control board has registered that the pressure transducer has failed on the control board or the calibration has failed. The blower will continue to run during this fault.

**OPEN COIL 1-** The control board has recognized an open circuit on the primary coil (coil 1) terminal. When a unit has this warning, the display screen will flash the warning. The fan will not run until the warning is resolved or after a 2 minute delay.

### Unit Configuration: COOL ONLY FOR BOTH MODELS

Expected inputs: Y's or W's.

Detected input: OB

#### ERRORS:

Error 1: Unexpected OB, Configuration error. Wiring error.

Error 2: Unexpected W's + OB, Configuration error. Wiring error.

Error 3: Unexpected Y's + OB, Configuration error. Wiring error.

Error 4: Unexpected Y's + W's, Configuration error. Wiring error.

### Unit Configuration: HEAT ONLY FOR WCS ONLY

Expected inputs: W's.

Detected inputs; Y's, Y's+OB, or OB

#### ERRORS:

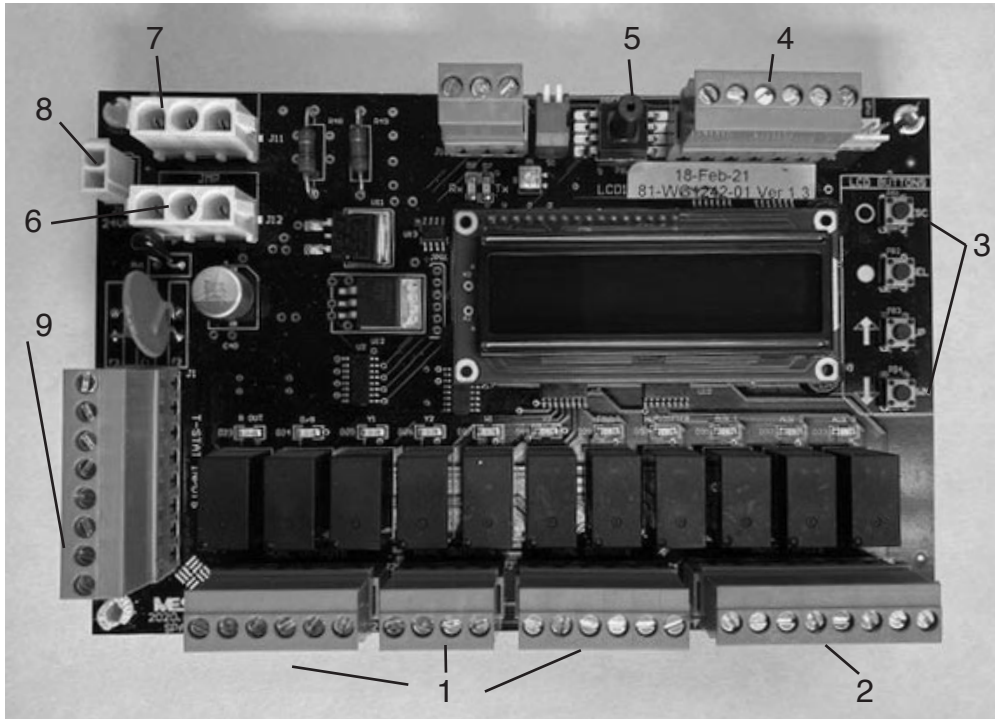
Error 1: Unexpected OB, Configuration error. Wiring error.

Error 3: Unexpected Y'S + OB, Configuration error. Wiring error

Error 5: Unexpected Y'S, Configuration error. Wiring error.

## ADDITIONAL SUPPLEMENTARY FEATURES OF THE J+ CONTROL

The J+ control has 3 inputs that can be used to interface with supplemental equipment. These inputs are enabled when 24VAC is applied.



1	HVAC Outputs
2	HVAC Inputs
3	LCD Buttons
4	Temperature
5	Pressure
6	JMP
7	FAN
8	24VAC
9	T-Stat Inputs

### Energy Recovery

An Energy Recovery Ventilator can use the [ERV] input to have the J+ unit run the fan. If the fan is already running, the fan will continue to run at the speed set by the active thermostat inputs. If the fan is not running the fan will run at the [ERV] fan setting.

### Humidifier

The Humidifier [HUM] input can be used to have the J+ control enable an external humidifier by using the [HUMDFR] relay output. The [HUMDFR] relay output is a dry set of contacts. If the fan is running already the fan will continue to run at the speed set by the active thermostat inputs. If the fan is not running the fan will run at the humidifier [HUM] fan setting.

### HP Defrost

The DFS terminals on the control board are designed to accept a 24v signal from an outdoor HP during it's defrost cycle. For firmware versions (see section on how to check firmware versions) 1.6 or greater, In this mode, if the fan is running already the fan will continue to run at the speed set by the active thermostat inputs. Once the delivered air-flow is measured with a CFM greater than 300 (verify on the display screen) the W2 relay output will be enabled. If the fan is not running the fan will run at the defrost [DFS] fan settings. In versions 1.5 or less, if there is already a demand from the thermostat inputs the fan speed will change to the DFS speed (or static pressure set point) then change back once DFS call has been removed.

### Fault Relay

The fault relay will close under the following conditions. When the float switch is tripped or if the pressure is less than 0.1 IWC after the pressure prove time has elapsed.

## SYSTEM COMMISSIONING

1. Check that system static pressure is within acceptable limits (minimum 1.2" WC -, maximum 1.5" WC). You can use a U-tube manometer to check the external static pressure on the duct system.
  - I. Puncture a ¼" diameter hole in the plenum duct at least 18" from the fan coil unit.
  - II. Insert the high-side manometer tube into the hole so that the end is approximately flush with the inside wall of the plenum, and perpendicular to the direction of airflow.
  - III. System static pressure should be between 1.2" and 1.5" WC.
    - a. If the pressure is higher than 1.5" provide additional supply runs to increase airflow or lower fan speed by turning the fan speed adjustment for the current mode of operation counter-clockwise to reduce the static pressure.
    - b. If the pressure is lower and 1.2", look for leaks in the supply plenum or restrictions in the return system (including clogged filters). If more than the recommended number of supply runs are installed, you may install flow restrictors (orifices) in these runs. If the number of runs is appropriate for the load, increase the static pressure by turning fan speed adjustment for the current mode of operation clockwise to increase the static pressure.
2. Check that blower motor amp draw compares with fan coil unit rating plate. Amp draw shown on plate is the FLA of motor (not the actual running amps) and will vary with the pressure and voltage.
3. Place the thermostat cooling indicator in COOL position, which will start the outdoor unit. Let the system run for at least 30 minutes to stabilize operating conditions.
4. For outdoor unit start up, follow manufacturer's instructions.
5. Check that temperature drop across the water coil in the indoor unit is between 20°F and 28°F.
6. Check the chiller or boiler for proper operation according to the manufacturer's instructions.

## FACTORS AFFECTING THE BALANCE OF THE SYSTEM

- A. Room Terminators (Outlets): Based on the equipment selected, determine the recommended number of fully open outlets from Figure 3.1.

**FIGURE 3.1**

RECOMMENDED OUTLETS AND CFM'S						
Model Size	Nominal Tonnage (outdoor unit)	Recommended CFM/outlet	Number of outlets A	Number of outlets B	Total CFM A	Total CFM B
2430	2	33	12	14	396	462
2430	2.5		15	18	495	594
3642	3		18	21	594	693
3642	3.5		21	25	693	825
4860	4		26	28	858	924
4860	5		30	35	990	1155

**FIGURE 3.2**

DESIRED NUMBER OF TERMINALS*	TERMINAL - ORIFICE COMBINATION
.5	(1) .5
.65	(1) .35
.85	(1) .15
1.00	(1)
1.15	(1) .5 + (1) .35
1.30	(2) .35
1.50	(1) .35 + (1) .15 or (1) + (1) .5 or (3) .5
1.65	(1) + (1) .35 or (2) .5 + (1) .35
1.70	(2) .15
1.80	(2) .35 + (1) .5
1.85	(1) + (1) .15
1.95	(3) .35
2.00	(2)

\*For a room with more than two (2) terminals, combinations of the above may be used to achieve the desired fractional number.

1. The minimum or recommended number of outlets means fully open outlets. Any outlet having an orifice would be only a percentage of an outlet.
2. For systems with average supply tubing lengths of 15 feet or less, use column A. For systems with supply tubing lengths greater than 15 feet, use column B.

**NOTICE: The number of outlets and average length of the supply tubing has a significant effect on the overall system performance. It is highly recommended that the adjustment factors outlined in the SpacePak Application Manual are accounted for prior to any installation.**

- B. Orifice Combinations: Should orifices be required to balance the system (installed at plenum take-off), refer to the combinations listed in Figure 3.2.

- C. Supply Tubing Length: An outlet with a supply tubing length of 15 feet is considered one, fully opened outlet. For other lengths refer to Figure 3.3 for adjustment factors.

**FIGURE 3.3**

2" SUPPLY TUBING LENGTH ADJUSTMENT FACTOR CHART								
RUN	6'	8'	10'	12'	15'	20'	25'	30'
FACTOR	1.18	1.14	1.11	1.06	1.0	.9	.8	.66

## SECTION 4: MAINTENANCE & TROUBLESHOOTING

The SpacePak system has been designed to provide years of trouble-free performance in normal installations. Examination by the homeowner at the beginning of each cooling season, and in mid-season should assure continued, good performance. In addition, the system should be examined by a qualified service professional at least once every year.

### BEFORE EACH COOLING SEASON

1. Check and clean air filter. The SpacePak air filter is permanent type. If the filter is the SpacePak filter, remove and clean thoroughly with soap solution and water. If the filter is a field supplied (non-SpacePak filter) follow that manufacturer's instructions on how to maintain.

**⚠ WARNING** Turn off electrical power supply before servicing. Contact with live electric components can cause shock or death.

2. Check fan coil unit. Turn off unit power disconnect switch and remove service access panels.
  - a. Inspect evaporator coil and blower wheel for build-up of dust and dirt. Clean with specific indoor coil cleaning products ONLY. Any deviation can void the warranty of the coil.
  - b. Replace service access panels and turn on unit power disconnect switch.
3. Check that unit condensate drain is clear and free running, and plug is in cleanout.
4. For outdoor condensing unit, follow manufacturer's maintenance instructions.

### IF SYSTEM FAILS TO OPERATE

1. Refer to the troubleshooting guide in this manual.
2. Contact a local HVAC professional.
3. Contact SpacePak technical support.

# TROUBLESHOOTING GUIDE

## Faults displayed on screen

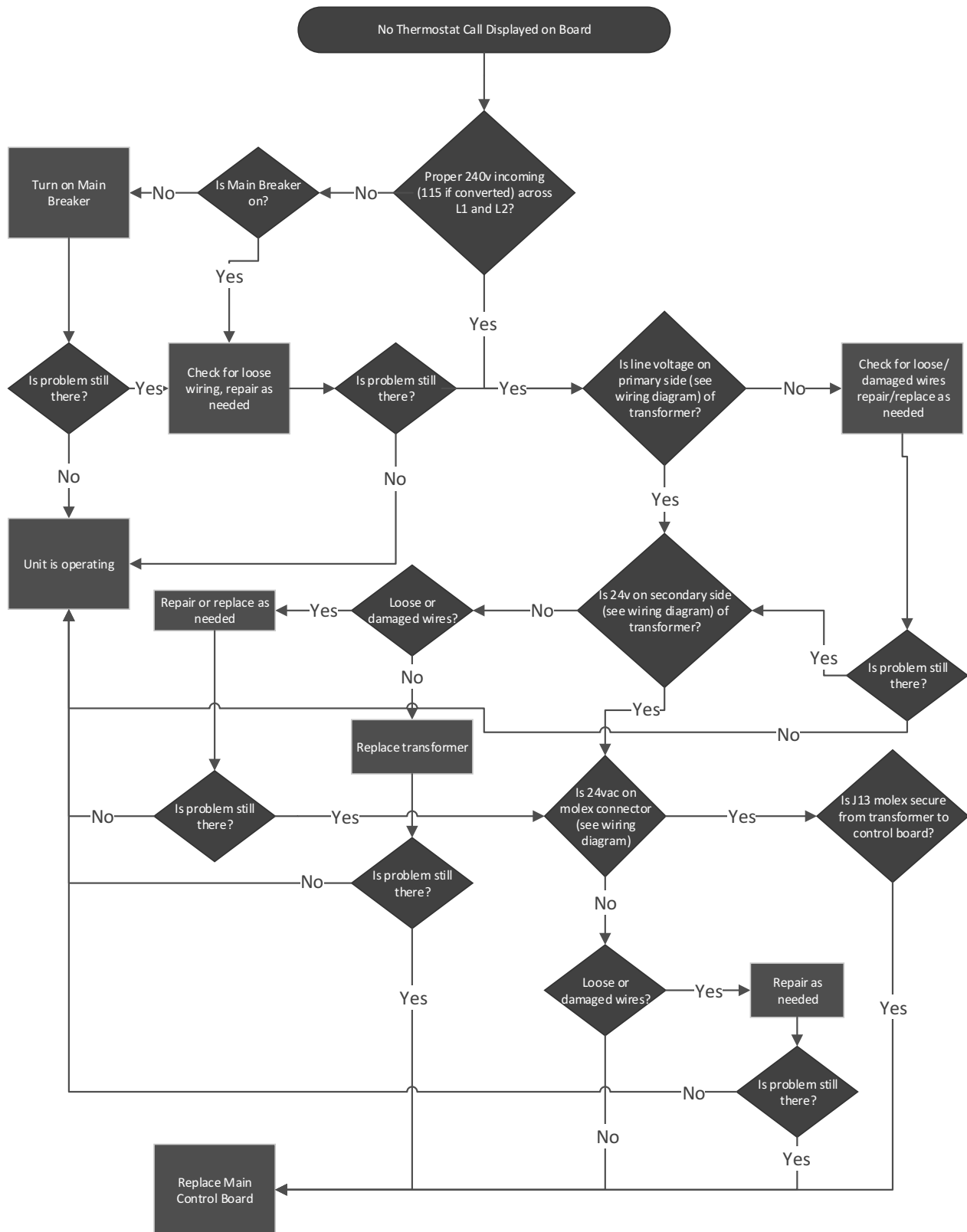
Display	Unit Type	Description	Possible Causes	Solutions
FLOAT SW FAULT	ESP/WCSP	The primary drain pan float switch has faulted. A Y call to the outdoor unit will not be allowed. Hard lockout, requires a power cycle to reset.	Clogged drain causing float switch to trip	Identify location of clog and clear clog
			Broken float switch	Inspect for damage. Replace as needed
			Wiring disconnected at control board or switch	Use ohm meter to test leads. Manually lift float. If ohm meter is "open" then check wiring or break in wire. Replace/repair as needed.
ANTIFROST FAULT	ESP/WCSP	The anti-frost sensor (located on primary coil) has gone below the "AFST" set point (see flow chart above for setting). This can be seen as "Coil 1 Temp" in the display screen.	Low-Refrigerant Charge	Ensure proper subcooling and charger per outdoor unit manufacturers recommendations Refrigerant leak in system. Inspect all refrigerants components to identify if a leak is present. Repair/replace as needed.
			Low airflow	Check return air filter. If dirty, clean/replace filter Check for restrictions in ductwork
				Check for proper airflow to the space by measuring delivered CFM/outlet. CFM/outlet in space should be between 30-40 CFM/Outlet. Increase airflow by navigating through menus (see above) and adjusting airflow for the proper input (Y1, Y2, G etc...)
			Sensor is reading incorrectly	Unplug sensor from control board. Read resistance across sensor and use resistance chart (below) to compare against a known temperature. If temperature is reading incorrectly and does not match chart, replace sensor.
LOW PRESS FAULT	ESP/WCSP	The pressure transducer is registering less than 0.1" when the fan is running	Hose is pinched or clogged	Verify hose and pressure tap on blower is clear. If hose is pinched, unpinch or replace. If hose/tap is clogged, unclog or replace.
			Pressure transducer has failed	Remove hose from blower port. Technician can blow into hose end that is connected to the blower and verify if display on board registers a pressure. If no pressure, replace board.
TRANSDUCER FAULT	ESP/WCSP	The pressure transducer has failed	Damage	Inspect transducer for damage. Replace control board
OPEN COIL 1	ESP/WCSP	The coil 1 temperature sensor is open	Damage	Inspect wiring and sensor to determine if coil one sensor has been damaged. If damaged, replace sensor
			Loose wire	The coil 1 sensor should be secured tightly to the terminals on the control board. Is loose, retighten.
SHORTED COIL 1	ESP/WCSP	The coil 1 temperature sensor is shorted	Damage	Inspect wiring for knicks or cuts that could be causing a short
OPEN COIL 2	ESP/WCSP	The coil 2 temperature sensor is open	Damage	Inspect wiring and sensor to determine if coil one sensor has been damaged. If damaged, replace sensor
			Loose wire	The coil 2 sensor should be secured tightly to the terminals on the control board. Is loose, retighten.
SHORTED COIL 2	ESP/WCSP	The coil 2 temperature sensor is shorted	Damage	Inspect wiring for knicks or cuts that could be causing a short
OPEN LAT	ESP/WCSP	The leaving air temperature sensor is open	Damage	Inspect wiring and sensor to determine if coil one sensor has been damaged. If damaged, replace sensor
			Loose wire	The coil 1 sensor should be secured tightly to the terminals on the control board. Is loose, retighten.
SHORTED LAT	ESP/WCSP	The LAT temperature sensor is shorted	Damage	Inspect wiring for knicks or cuts that could be causing a short
COIL 1 NOT FOUND	ESP/WCSP	If the board does not recognize a signal from the "coil 1" terminals. The unit will automatically then default and run the fan after the "fan on delay" timer has expired.	Disconnected sensor	Re-connect sensor
			No sensor	Add sensor
COIL 2 NOT FOUND	ESP/WCSP	If the board does not recognize a signal from the "coil 2" terminals. The unit will automatically then default and run the fan after the "fan on delay" timer has expired.	Disconnected sensor	Re-connect sensor
			No sensor	Add sensor
HWC DISABLE	ESP/WCSP	The coil 2 sensor is recognized and connected, but the SEC HW COIL is disabled	Incorrect programming	If a secondary hot water coil is installed, navigate through the menu tree to enable the "SEC HW COIL" function/feature.
			Sensor place in wrong location	A sensor is wired into the "coil 2" location incorrectly. Remove sensor and relocate to proper location.
Defrost	ESP/WCSP	The air handler has received a signal from the outdoor unit that the outdoor unit has gone into defrost	Outdoor unit has sent a defrost signal	If outdoor unit has sent a defrost signal, then normal operation. If outdoor unit has not sent a defrost signal, inspect for shorted wires from air handler to outdoor unit. Replace board if no short and unit is not sending a signal.

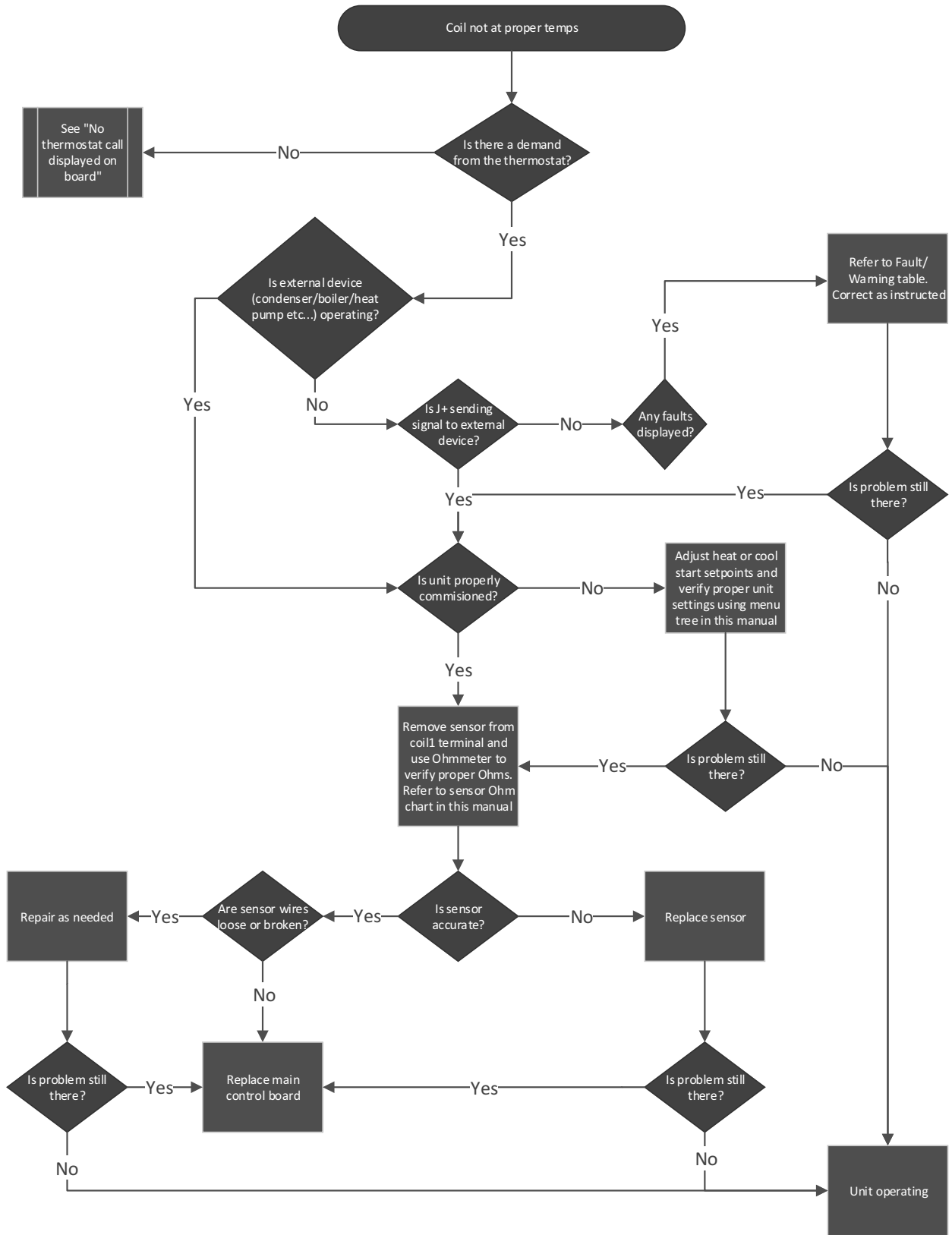
Project Complaints/Conditions*			
Problem	Possible Cause	Corrective Actions	
Poor Cooling	Refrigerant Leak	Check for refrigerant leaks in all refrigerant components. Repair leaks (as needed) per standard refrigeration practices	
	Improper charge	Check for proper refrigerant charge. Charge to proper subcooling according to condenser manufacturers instructions	
	Evaporator coil dirty	Check for a dirty evaporator coil. Clean evaporator coil using only evaporator approved cleaning solutions	
	Return air filter is dirty	If the return air filter is dirty. Inspect, clean or replace as needed	
	Low airflow		Inspect ductwork for damage or leakage of airflow. Repair as needed
			Adjust fan speed (per this manual) for each outlet to achieve a minimum of 33 cfm/outlet
			Add more outlets if required (minimum of 7/ton)
Improperly sized equipment.	Verify required Btu's by performing a heat loss calculation for the space. Compare to the equipment installed.		
Blower Will Not Run	No call from thermostat at board	See "No Thermostat Call Displayed on Board" flowchart for troubleshooting steps	
	Coil not at temps	The blower will not start unless the proper coil temp for the thermostat call (heating or cooling) See "Coil not at proper temps" flowchart for more troubleshooting steps	
	Verify proper voltage	Using the wiring diagram in this manual, identify the line voltage terminals going to the blower. Using a calibrated voltmeter, verify proper voltage to blower. 240v is standard, if unit has been converted for 115v then 115v should be applied to the blower. See "Improper voltage" flowchart for more troubleshooting steps	
	Static Pressure Hose may be kinked	From the main screen on the display, press the "up" or "down" keys to find "S.P" reading. If blower is not running and the screen is displaying a measure reading, then hose is kinked. Trace hose to locate the kink and repair. If hose is not kinked, replace control board	
	Unit not commissioned properly	Using the menu tree in this manual, verify the unit has been commissioned properly for the application.	
	Unit speed or static pressure set point set incorrectly	Using the menu tree in this manual, verify that the blower is set to the proper speed or SP set point for the appropriate thermostat input. Y1, G, Y2 etc...	
Control Board not powered	Improper Voltage	Ensure all wiring is proper per wiring diagrams. The board requires 24v from transformer to power up. Repair as needed. See flowcharts "No thermostat call" and "Improper voltage" in this manual for more troubleshooting steps.	
	Faulty Control Board	If wiring has been confirmed to be good, no loose connections, then replace control board.	
Auxiliary terminal not closing	Improper commissioning	Using the menu tree in this manual, verify the auxiliary terminals have been commissioned to close per the desired thermostat call.	
	Faulty Control Board	If board is properly commissioned, and LED light for auxiliary terminal is illuminated, then replace control board.	
Coil is freezing	No airflow	See "Blower will not run" above.	
	Low airflow	Measure delivered airflow to the space and compare against "Required CFM's" table in this manual. If low, adjust accordingly	
		Dirty air filter. Clean/replace as needed	
		Dirty evaporator coil. Clean as required	
		Inspect ductwork for damage or leakage of airflow. Repair as needed	
Refrigerant Leak	Check for refrigerant leaks in all refrigerant components. Repair leaks (as needed) per standard refrigeration practices		
Improper charge	Check for proper refrigerant charge (with proper airflow established). Charge to proper subcooling according to condenser manufacturers instructions		
Sweating at Supply Outlet	Air Leak at Supply Air Plenum	Check taped joint at adapter. Tape joint properly if necessary.	
	Insulation at Outlet not Installed	Check for insulation at the outlet. Make repairs if necessary.	
Excessive Noise at Terminator	High Supply Air Plenum Static Pressure	Check static pressure and compare to the table provided in this manual. Check for and add flow restrictors as necessary in supply runs.	
		Check static pressure and compare to the table provided in this manual. If necessary, add additional outlets.	
	Sound Attenuating Tube not Installed	Check for installation of sound attenuating tube. Where necessary, install sound attenuating tube.	
	Tight Radius in Sound Attenuating Tube or in Supply Tubing	Check all tubing for tight radius. Where necessary, correct radius.	
	Incorrect Supply Tubing Length	Check that all supply tubing runs are 9ft minimum (including the 3ft sound atten. tube). Where necessary, correct supply tubing length.	
Improperly Balanced System	Check that correct size orifices have been installed. If not, properly orifice supply tubing runs.		
Excessive Noise at Return Air Grill	Return Air Duct Not Installed Properly	Check for minimum 90° bend in return air duct. If minimum requirement not met, correct the bend in the return air duct to the 90° minimum.	
	Dirty Return Air Filter	Remove and inspect the return air filter. Clean or replace filter as needed.	
Excessive Vibration	Foreign Matter in Blower Wheel	Check for loose or damaged blower wheel. Replace Blower Assembly of necessary.	
	Blower Wheel Damaged or Unbalanced	Remove and Inspect Blower Assembly. Remove and foreign matter and retest fan vibration.	

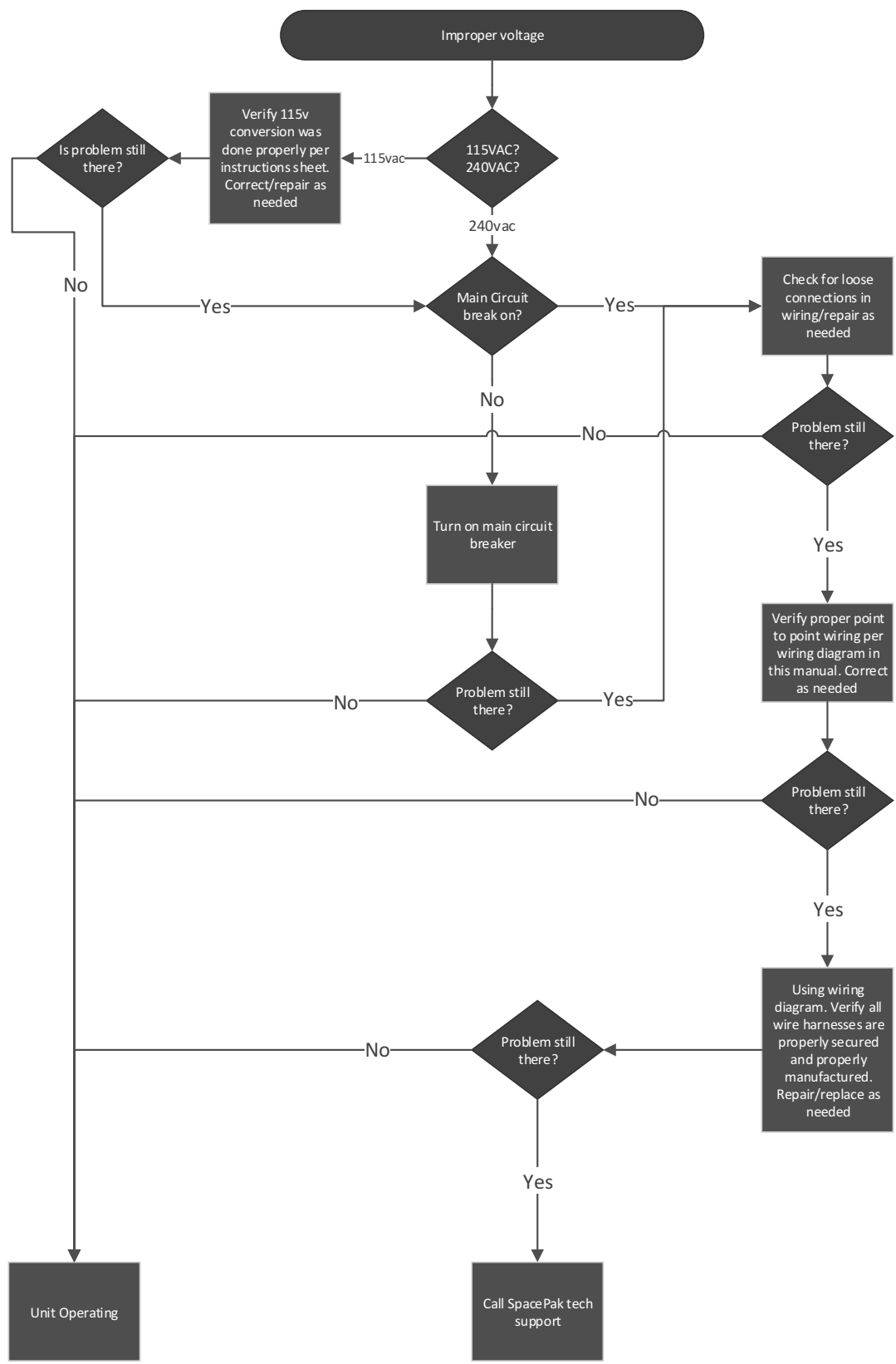
\* The table above explains the most common symptoms and solutions for SpacePak troubleshooting. Please reach out to technicalservice@spacepak.com if the problem is not resolved using this table.



# TROUBLESHOOTING FLOW CHARTS







**10k OHM TEMP SENSOR RESISTANCE TABLE (LAT Sensor and Coil Sensor)**

°C	°F	W
-40	-40	336,098
-35	-31	242,427
-30	-22	176,803
-25	-13	130,306
-20	-4	97,006
-15	5	72,911
-10	14	55,307
-5	23	42,317
0	32	32,651
5	41	25,395
10	50	19,903
15	59	15,714
20	68	12,493
25	77	10,000
30	86	8,056
35	95	6,530
40	104	5,325
45	113	4,367
50	122	3,601
55	131	2,985
60	140	2,487
65	149	2,082
70	158	1,752
75	167	1,480
80	176	1,256
85	185	1,076
90	194	916
95	203	787
100	212	678



Service / Troubleshooting FORM "1A"

Customer / Dealer Data:

Name: \_\_\_\_\_
Address: \_\_\_\_\_
Tel (day) \_\_\_\_\_ (eve) \_\_\_\_\_
Installing Dealer / Contractor:

Name: \_\_\_\_\_
Tel: \_\_\_\_\_

Refrigeration-side Data:

Line sizes: Liquid \_\_\_\_\_ Suction \_\_\_\_\_
Total equivalent length of lines: \_\_\_\_\_ Ft; Vertical Rise: \_\_\_\_\_ Ft.
@ Condensing Unit:
Liquid: \_\_\_\_\_ psi; Temp: \_\_\_\_\_ °F; Subcool: \_\_\_\_\_ °F
Suction: \_\_\_\_\_ psi; Temp: \_\_\_\_\_ °F; Superheat: \_\_\_\_\_ °F
@SpacePak:
Liquid: \_\_\_\_\_ psi; Temp: \_\_\_\_\_ °F; Subcool: \_\_\_\_\_ °F
Suction: \_\_\_\_\_ psi; Temp: \_\_\_\_\_ °F; Superheat: \_\_\_\_\_ °F
Approximate time running before taking readings: \_\_\_\_\_ Hrs.
Did you adjust the TXV? \_\_\_\_\_ (Y/N); (If yes, explain):

Equipment Data:

SPACEPAK Model # ESP / WCSP - \_\_\_\_\_
SPACEPAK Serial # \_\_\_\_\_
SPACEPAK Date of Installation: \_\_\_\_\_
Cond Unit Mfr: \_\_\_\_\_
Cond Unit Mod #: \_\_\_\_\_
Rated Capacity: \_\_\_\_\_ BTUH; SEER: \_\_\_\_\_

Refrigerant Charge (if weighed-in): \_\_\_\_\_ lbs
R410a / R22 (circle one)
Installed options: (circle one)
sight glass filter/drier zone controls
Other: \_\_\_\_\_

Air-side Data:

Total # of outlets: \_\_\_\_\_; Supply tube length: \_\_\_\_\_ Ft (avg)
(Please sketch duct layout on reverse side of this sheet, noting all fittings and distances, including return duct size / length)
Air Filter: Size (LxHxD) \_\_\_\_\_
Type (pleated, etc): \_\_\_\_\_
Is the filter clean? \_\_\_\_\_ (Y/N)
Static Pressure (Ps) in supply plenum: \_\_\_\_\_ "WG
(Measure at approximately 3 ft downstream of blower discharge)
Ps in return duct (downstream of filter, upstream of coil) \_\_\_\_\_ "WG
SpacePak Motor: Amps (measured): \_\_\_\_\_ Amps
Voltage (measured): \_\_\_\_\_ Volts

Water Data: (where applicable)

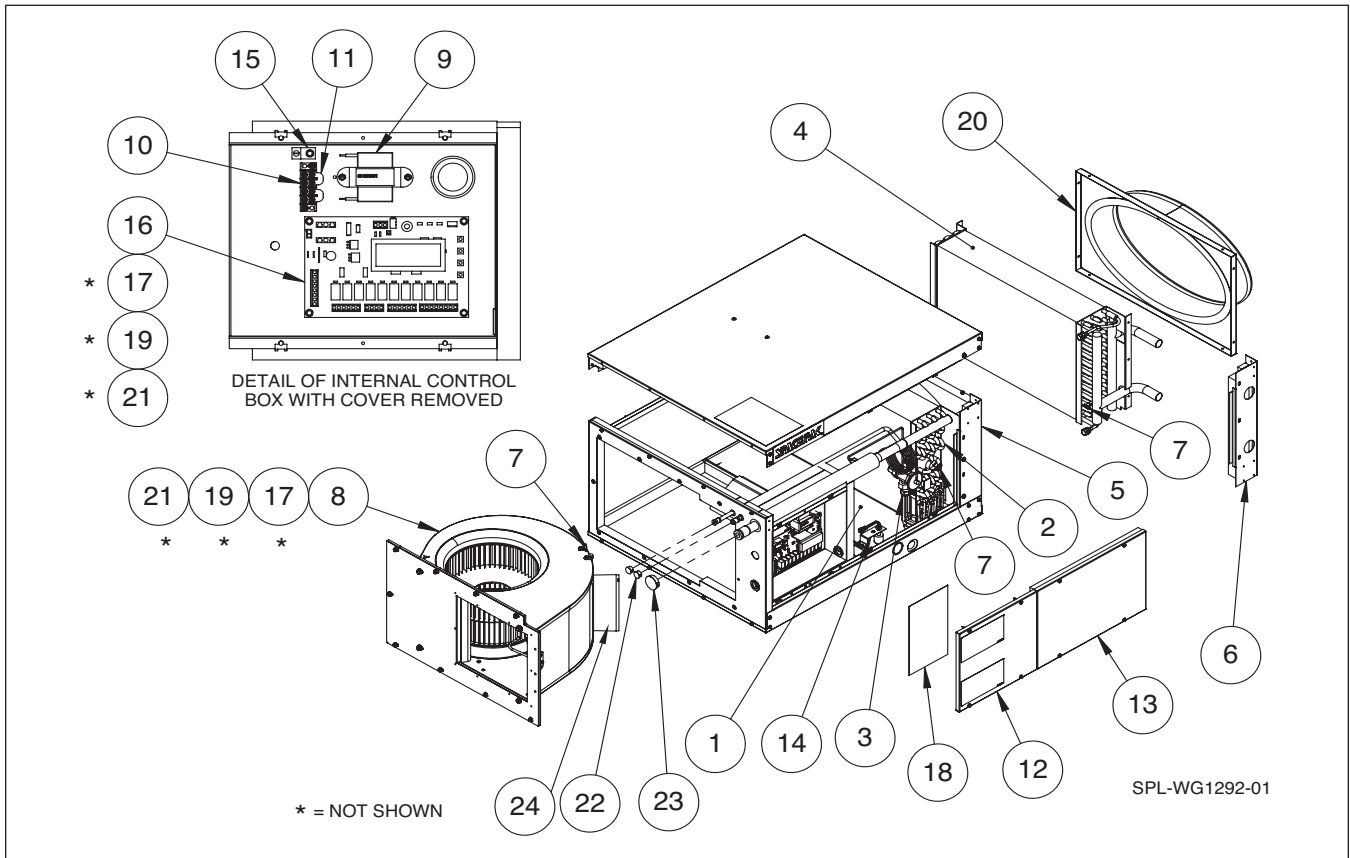
Line sizes: \_\_\_\_\_"; Length: \_\_\_\_\_ FT
Water temperatures:
Supply: \_\_\_\_\_ °F; Return \_\_\_\_\_ °F
Glycol?: \_\_\_\_\_ (Y/N); % Solution: \_\_\_\_\_

Air Temperatures:

@ Return (indoor ambient): \_\_\_\_\_ °FDB; \_\_\_\_\_ °FWB
@ Condensing unit (outdoor ambient): \_\_\_\_\_ °F
@ AHU (read 3 ft from fan discharge) \_\_\_\_\_ °F
@ last supply outlet \_\_\_\_\_ °F

NOTES: \_\_\_\_\_
\_\_\_\_\_
\_\_\_\_\_

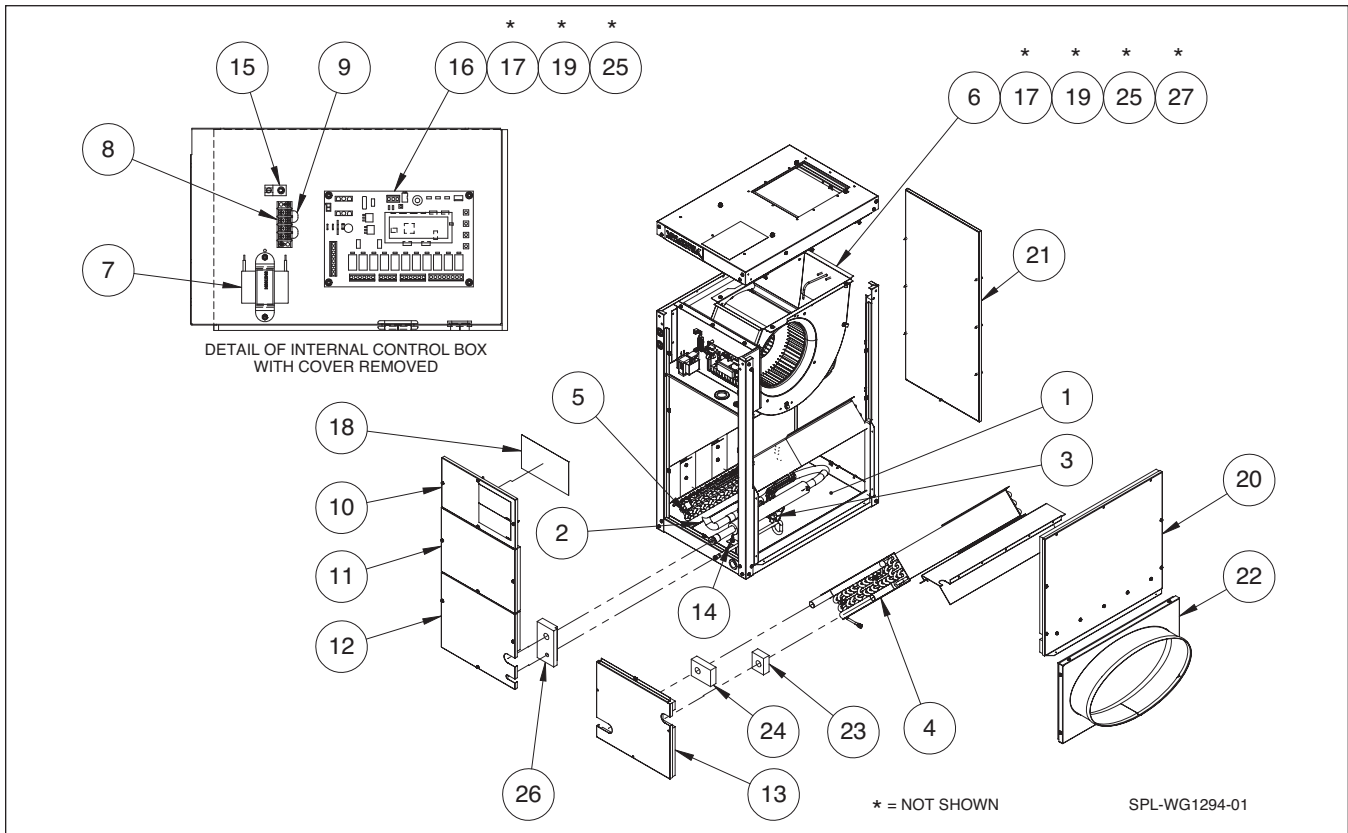
**FIGURE 4.1: MODEL WCSP-J GENERAL ASSEMBLY**



Replacement Parts - Horizontal Fan Coil Units					
Item	Part Description	Unit Size	Part Number	ESP	WCSP
1	Primary Drain Pan	2430J	45W06RWG0220-22	X	X
		3642J	45W06RWG0220-23	X	X
		4860J	45W06RWG0220-24	X	X
2	R410A Coil Assembly	2430J	45469RWG1270-02	X	
		3642J	45469RWG1270-03	X	
		4860J	45469RWG1270-04	X	
3	Thermal Expansion Valve, Chatleff Connection	2430J	45W28RWG0641-02	X	
		3642J	45W28RWG0641-03	X	
		4860J	45W28RWG0641-04	X	
4	Hydronic Coil Assembly	2430J	45W50RWG0631-02		X
		3642J	45W50RWG0631-03		X
		4860J	45W50RWG0631-04		X
5	Corner Post ESP Coil	All Sizes	45462-WG0530-01	X	
6	Corner Post WCSP Coil	All Sizes	45462-wg0530-02		X
7	Temperature Sensor with Plug End	All Sizes	45W09RWG1257-01	X	X
	Temperature Sensor without Plug End	All Sizes	45W09RWG1364-01	X	X
8	Blower Assembly - JH4MB	All Sizes	45W35RWG0802-10	X	X
	Blower Assembly - JH4MC	All Sizes	45W35RWG1539-10	X	X
9	Transformer	All Sizes	45W14RWG1234-01	X	X
10	Terminal Block	All Sizes	45W09RWG1263-04	X	X
11	Jumper, Terminal Block	All Sizes	45W09RWG1264-01	X	X
12	Electrical Control Box Cover	All Sizes	45462RWG1245-01	X	X
13	Coil Access Panel	All Sizes	45462RWG0914-01	X	X
14	Primary Float Switch*	All Sizes	45W06RWG0268-01	X	X
15	Cable Connector (Ground)	All Sizes	45W09RWG0313-01	X	X
16	J+ Control Board (Black with Display Screen)	All Sizes	45W11RWG1242-01	X	X
17	Wire Harness, Motor Control	All Sizes	45460RWG1235-01	X	X
18	Wiring Diagram	All Sizes		X	X
19	Blower Speed Control Cable	All Sizes	45W11RWG0807-01	X	X
		2430J	45463RWG0708-02	X	X
		3642J	45463RWG0708-03	X	X
20	Return Air Panel Assembly	4860J	45463RWG0708-04	X	X
21	Silicone Tubing, 3/16ID	All Sizes	11H07R01471-002	X	X
22	Snap Plug, 5/8 ID	All Sizes	11J07-01019-015		X
23	Snap Plug, 1-3/8 ID	All Sizes	11J07-01019-037		X
24	ECM Controller - JH4MB	All Sizes	45W11RWG0926-10	X	X
	ECM Controller - JH4MC	All Sizes	45W11RWG1540-10	X	X

\*Switch only, for full assembly contact TechnicalService@SpacePak.com

**FIGURE 4.2: MODEL WCSP-JV GENERAL ASSEMBLY**



\* = NOT SHOWN

SPL-WG1294-01

Replacement Parts - Vertical Fan Coil Units					
Item	Part Description	Unit Size	Part Number	ESP	WCSP
1	Primary Drain Pan Assembly	2430J	45455RWG1012-02	X	X
		3642J	45455RWG1012-03	X	X
		4860J	45455RWG1012-04	X	X
2	R410A Coil Assembly	2430J	45469RWG1013-02	X	
		3642J	45469RWG1013-03	X	
		4860J	45469RWG1013-04	X	
3	Thermal Expansion Valve, Chatleff Connection	2430J	45W28RWG0641-02	X	
		3642J	45W28RWG0641-03	X	
		4860J	45W28RWG0641-04	X	
4	Hydronic Coil Assembly	2430J	45W50RWG0660-02		X
		3642J	45W50RWG0660-03		X
		4860J	45W50RWG0660-04		X
5	Temperature Sensor with Plug End	All Sizes	45W09RWG1257-01	X	X
	Temperature Sensor without Plug End	All Sizes	45W09RWG1364-01	X	X
6	Blower Assembly - JH4MB	All Sizes	45W35RWG0802-10	X	X
	Blower Assembly - JH4MC	All Sizes	45W35RWG1539-10	X	X
7	Transformer Assembly	All Sizes	45W14RWG1234-01	X	X
8	Terminal Block	All Sizes	45W09RWG1263-04	X	X
9	Jumper, Terminal Block	All Sizes	45W09RWG1264-01	X	X
10	Electrical Control Box Cover	All Sizes	45456-WG1240-01	X	X
11	Center Access Panel Assembly	All Sizes	45458RWG0975-01	X	X
12	Access Panel, R410A Coil	All Sizes	45458RWG0725-01	X	
13	Access Panel, Hydronic Coil	All Sizes	45458RWG0665-01		X
14	Primary Float Switch	All Sizes	45455RWG1009-01	X	X
15	Cabel Connector (Ground)	All Sizes	45W09RWG0313-01	X	X
16	J+ Control Board (Black with Display Screen)	All Sizes	45W11RWG1242-01	X	X
17	Wire Harness, Motor Control	All Sizes	45460RWG1235-01	X	X
18	Wiring Diagram	All Sizes		X	X
19	Blower Speed Control Cable	All Sizes	45W11RWG0807-01	X	X
20	Blower Access Panel Assembly	2430J	45462RWG0691-02	X	X
		3642J	45462RWG0691-03	X	X
		4860J	45462RWG0691-04	X	X
21	Side Access Panel Assembly	All Sizes	45462RWG1007-01	X	X
22	Return Air Panel Assembly	2430J	45463RWG0708-02	X	X
		3642J	45463RWG0708-03	X	X
		4860J	45463RWG0708-04	X	X
23	Insulation, Upper Coil Tube	All Sizes	45Y06-WG0663-01		X
24	Insulation, Lower Coil Tube	All Sizes	45Y06-WG0663-02		X
25	Tubing, HI-Temp, 3/16" ID	All Sizes	11H07-01471-002	X	X
26	Insulation, Coil Tube	All Sizes	45Y06-WG0726-01	X	
27	ECM Controller - JH4MB	All Sizes	45W11RWG0926-10	X	X
	ECM Controller - JH4MC	All Sizes	45W11RWG1540-10	X	X

# IMPORTANT NOTICE

## PRODUCT REGISTRATION & EXTENDED WARRANTY

### Extended Warranty Requirements

- Project/Equipment Registration
- Active SpacePak Certified Contractor Status at Time of Installation

To visit the **Product Registration Page**, click or scan the QR code.



### Are You Certified?

Check our **Contractor Locator** map to find out.

### Benefits of Becoming a SpacePak Certified Contractor:

- Local Leads
- Listed on SpacePak Website
- Sales & Marketing Support
- Pre-Sale Application Support & Load Calculations
- Extended Warranty

### SpacePak Offers Factory Authorized Training for Certification On:

- Small Duct High Velocity Equipment
- Air-to-Water Heat Pump & Hydronic Equipment

### Available Training Certification - Methods Include:

- Online Webinar Training
- Local Field Training
- Corporate Headquarter Factory Training

### For All Training Inquiries, Contact Your Local SpacePak Manufacturers Representative:

<https://www.spacepak.com/RepLocator>





## LIMITED WARRANTY STATEMENT

### SpacePak “Solstice Inverter”\*\* Series Air to Water Heat Pumps

Subject to the terms and conditions of this Limited Warranty Statement (the “Limited Warranty”), SpacePak warrants to the original purchaser of the “Solstice Inverter” Series that:

- 1) The parts are warranted for a period of two (2) years to the original owner of the System (as such term is defined in part (4) below). If any parts should prove defective due to improper workmanship and/or material for a period of two (2) years from the date of installation, SpacePak will replace any defective part without charge for that part. Replacement parts are warranted for the remainder of the original 2-year warranty period. Parts used as replacement may be of like kind and quality and may be new or remanufactured. Defective parts must be available for SpacePak in exchange for the replacement parts and become the property of SpacePak.
- 2) The compressor is warranted for a period of five (5) years to the original owner of the System. If the compressor should prove defective due to improper workmanship and/or material for a period of five (5) years from the date of installation, SpacePak will replace the defective compressor without charge for the compressor. Replacement compressors are warranted for the remainder of the original 5-year warranty period. Compressors used for replacement may be of like kind and quality and may be new or remanufactured. Defective compressors must be made available to SpacePak in exchange for the replacement compressor and become the property of SpacePak.
- 3) **Notwithstanding the foregoing, if the System is installed in a residential single-family home by a SPACEPAK CERTIFIED CONTRACTOR the parts will be warranted for five (5) years and compressor will be warranted for a period of ten (10) years, to the original owner, so long as the original owner resides in the home.** Specifically, if any parts and/or the compressor should prove defective due to improper workmanship and/or material for the period listed above from the date of installation, SpacePak will replace any defective parts or compressor without charge for the part or compressor. The replacement parts and/or compressor are warranted for the remainder of the original warranty period. Parts and/or compressors used for replacement may be of like kind and quality and may be new or remanufactured. Defective parts and/or compressors must be made available to SpacePak in exchange for the replacement parts and become the property of SpacePak.
- 4) For purposes of this Solstice Inverter” Series Limited Warranty, as used herein, the term “System” shall mean the Solstice Inverter outdoor and indoor components connected via refrigerant piping and electrical wiring purchased on or after February 1, 2021, (i) sold from a licensed HVAC representative of SpacePak (and not an unauthorized third party) to the original owner, (ii) installed by such contractor in accordance to local and National regulations in the continental U.S., Alaska, Hawaii, and Canada; and (iii) registered on SpacePak’s website located at [www.SpacePak.com/warranty](http://www.SpacePak.com/warranty))

\*For any Solstice equipment that is non-inverter, please refer to warranty located in the equipment original installation manual.

### SpacePak Small Duct High Velocity Air Handlers and Hydronic Fan Coils

Subject to the terms and conditions of this Limited Warranty Statement (the “Limited Warranty”), SpacePak warrants to the original purchaser of the Small Duct High Velocity Air Handlers and hydronic fan coils that:

- 1) The parts are warranted for a period of one (1) year to the original owner of the System (as such term is defined in part (3) below). If any parts should prove defective due to improper workmanship and/or material for a period of one (1) year from the date of installation, SpacePak will replace any defective part without charge for that part. Replacement parts are warranted for the remainder of the original 1-year warranty period. Parts used as replacement may be of like kind and quality and may be new or remanufactured. Defective parts must be available for SpacePak in exchange for the replacement parts and become the property of SpacePak.
- 2) Notwithstanding the foregoing, if the System is installed in a residential single-family home by a SPACEPAK CERTIFIED CONTRACTOR the parts will be warranted for five (5) years, to the original owner, so long as the original owner resides in the home. Specifically, if any parts should prove defective due to improper workmanship and/or material for the period listed above from the date of installation, SpacePak will replace any defective parts or compressor without charge for the part or compressor. The replacement parts are warranted for the remainder of the original warranty period. Parts used for replacement may be of like kind and quality and may be new or remanufactured. Defective parts must be made available to SpacePak in exchange for the replacement parts and become the property of SpacePak.
- 3) For purposes of this Small Duct High Velocity Air Handlers and hydronic fan coils limited warranty, as used herein, the term “System” shall mean the “SpacePak Small Duct High Velocity Air Handlers, hydronic fan coils purchased on or after February 1, 2021, (i) sold from a licensed HVAC representative of SpacePak (and not an unauthorized third party) to the original owner, (ii) installed by such contractor in accordance to local and National regulations in the continental U.S., Alaska, Hawaii, and Canada; (iii) registered on SpacePak’s website located at [www.SpacePak.com/warranty](http://www.SpacePak.com/warranty)); and (iv) comprised of SpacePak original components or SpacePak certified components. TO THE EXTENT THAT NON-SPACEPAK OR NON-SPACEPAK CERTIFIED COMPONENTS ARE UTILIZED IN THE SYSTEM, ALL WARRANTIES SHALL NOT BE APPLICABLE.

## SpacePak Buffer Tanks

The “Manufacturer” warrants to the original owner at the original installation site that the Hydronic Buffer Tanks (the “Product”) will be free from defects in material or workmanship for a period not to exceed ten (10) years from the startup, provided the product is installed in accordance with the manufacturers installation instructions. If upon examination by the Manufacturer the Product is shown to have a defect in material or workmanship during the warranty period, the Manufacturer will repair or replace, at its option, that part of the Product which is shown to be defective.

### The following items apply to each Limited Warranty offered by SpacePak.

- 4) **NO LABOR.** Each Limited Warranty offered by SpacePak does NOT include labor or any other costs incurred for service, maintenance, repair, removing, replacing, installing, complying with local building and electric codes, shipping or handling, or replacement of the System/Products, compressors or any other parts. For items that are designed to be maintained or replaced by the original owner, the original owner is solely responsible for all labor and other costs of maintaining, installing, replacing, disconnecting or dismantling the System/ Products and parts in connection with owner-required maintenance. Please consult the applicable technical documentation for regularly suggested maintenance procedures.
- 5) **PROPER INSTALLATION.** This Limited Warranty applies only to Systems/Products that are sold by SpacePak HVAC representatives, installed by contractors who are licensed for HVAC installation under applicable local and state law, and who install the Systems/Products in accordance with (i) all applicable building codes and permits: (ii) SpacePak’s installation and operation instructions: and (iii) good trade practices.
- 6) **BEFORE REQUESTING SERVICE,** please review the applicable technical documentation to insure proper installation and correct customer control adjustment for the System/Products. If the problem persists, please arrange for warranty service.
  - a. **TO OBTAIN WARRANTY SERVICE:**
    - i. Contact the licensed contractor who installed the System/Products or the nearest licensed contractor, dealer, or distributor (whose name and address may be obtained on our website at [www.SpacePak.com](http://www.SpacePak.com) of any defect within the applicable warranty time period.
    - ii. Proof of the installation date by a licensed contractor is required when requesting warranty service. Present the sales receipt, building permit or other document which establishes proof and date of installation. In the absence of acceptable proof, this Limited Warranty shall be deemed to begin one hundred twenty (120) days after the date of manufacture stamped on the System/Products.
    - iii. This Limited Warranty applies only to System/Products purchased on or after February 1, 2021 only while the System/Products remains at the site of the original installation, and only to locations within the continental United States, Alaska, Hawaii and Canada.
    - iv. Shipment, to the Manufacturer, of that part of the Product thought to be defective. Goods can only be returned with prior written approval from the Manufacturer. All returns must be freight prepaid. Determination, in the reasonable opinion of the Manufacturer, that there exists a defect in material or workmanship.
  - b. **THIS LIMITED WARRANTY DOES NOT COVER:** property damages, malfunction or failure of the System/Products, or personal injury caused by or resulting from: (a) accident, abuse, negligence or misuse; (b) operating the System/Products in a corrosive or wet environment, including those containing chlorine, fluorine or any other hazardous or harmful chemicals or environmental factors, including sea- or salt-water; (c) installation, alteration, repair or service by anyone other than a licensed contractor or other than pursuant to the manufacturer’s instructions; (d) improper matching of System/Products components; (e) improper sizing of the System/Products; (f) improper or deferred maintenance contrary to the manufacturer’s instructions; (g) physical abuse to or misuse of the System/Products (including failure to perform any maintenance as described in the Operation manual, or any System/ Products damaged by excessive physical or electrical stress; (h) System/Products that have had a serial number or any part thereof altered, defaced or removed; (i) System/Products used in any manner contrary to the Operation Manual; (j) freight damage; or (k) events of force majeure or damage caused by other external factors such as lightning, power surges, fluctuations in or interruptions of electrical power, rodents, vermin, insects, or other animal- or pest-related issues.
  - c. **THIS LIMITED WARRANTY ALSO EXCLUDES:** (a) SERVICE CALLS WHERE NO DEFECT IN THE SYSTEM/PRODUCTS COVERED UNDER THIS WARRANTY IS FOUND: (b) System/Products installation or set-ups; (c) Adjustments of user controls; (d) System/Products purchased or installed outside the continental United States, Alaska, Hawaii and Canada; or (e) System/Products purchased or installed prior to **February 1, 2021**. Consult the operating instructions for information regarding user controls.



# **SPACEPAK®**

IN UNITED STATES: 260 NORTH ELM ST. WESTFIELD, MA 01085 (413) 564-5530  
IN CANADA: 7555 TRANMERE DRIVE, MISSISSAUGA, ONTARIO, L5S 1L4 (905) 670-5888