

Low Ambient Air to Water Reverse Cycle Heat Pump

STANDARD FEATURES

- Hermetically Sealed EVI Compressor
- Self-Diagnostic Control – Factory Programmed Two Variable Speed Fans
- Brazed-plate Refrigerant-to-Water Heat Ex.
- Quiet Operation – 54-62 dBA Based Upon Fan Speed
- R410A Refrigerant
- 230/1/60
- Durable Powder Coated Finish
- Configurable Defrost Logic
- Optimized for Buffer Tank Installation



MODEL: LAHP48 Qty. _____



Model	LAHP - 048	COP
Heating Capacity (47°F/8°C Ambient Temp. 120°F/50°C Supply Water)	66,480 BTU/h (18.9kW)	3.26
Heating Capacity (17°F/-8°C Ambient Temp. 120°F/50°C Supply Water)	46,440 BTU/h (13.6kW)	2.35
Heating Capacity (5°F/-15°C Ambient Temp. 120°F/50°C Supply Water)	42,240 BTU/h (12.4kW)	2.12
Cooling Capacity (95°F/35°C Ambient Temp. 44°F/6.7°C Supply Water)	40,000 BTU/h (11.7kW)	2.43
Volts	230V/1ph/60Hz	
Minimum Water Supply Temperature	42°F (5.5°C)	
Maximum Water Supply Temperature	131°F (55°C)	
Rated Water Flow	11 GPM (41.6 l/min)	
Pressure Drop at Recommended Flow	17.1 ft/7.4 PSI (35.8 kPa)	
Minimum Circuit Capacity	40	
Maximum Fuse/Circuit Breaker	60	
Noise Level at Max Fan Speed (Heating Or Cooling)	62 dB (A)	
Compressor	EVI Scroll	
Ship Weight	386 lbs (175 kg)	

SPACE PAK[®]
HYDRONICS

260 North Elm St., Westfield, MA 01085
 (800) 465-8558 Fax: (413) 564-5815

7555 Tranmere Drive, Mississauga, ONT. L5S 1L4 Canada
 (905) 670-5888 Fax: (905) 670-5782

www.spacepak.com

PROJECT: _____ **DATE:** _____

LOCATION: _____

CUSTOMER: _____

ENGINEER: _____

SUBMITTED BY: _____

FOR: Reference Approval Construction

UNIT DESIGNATION: _____

SCHEDULE NUMBER: _____

SUBMITTAL DATA: Heat Pump LAHP48 Series

DIMENSIONS

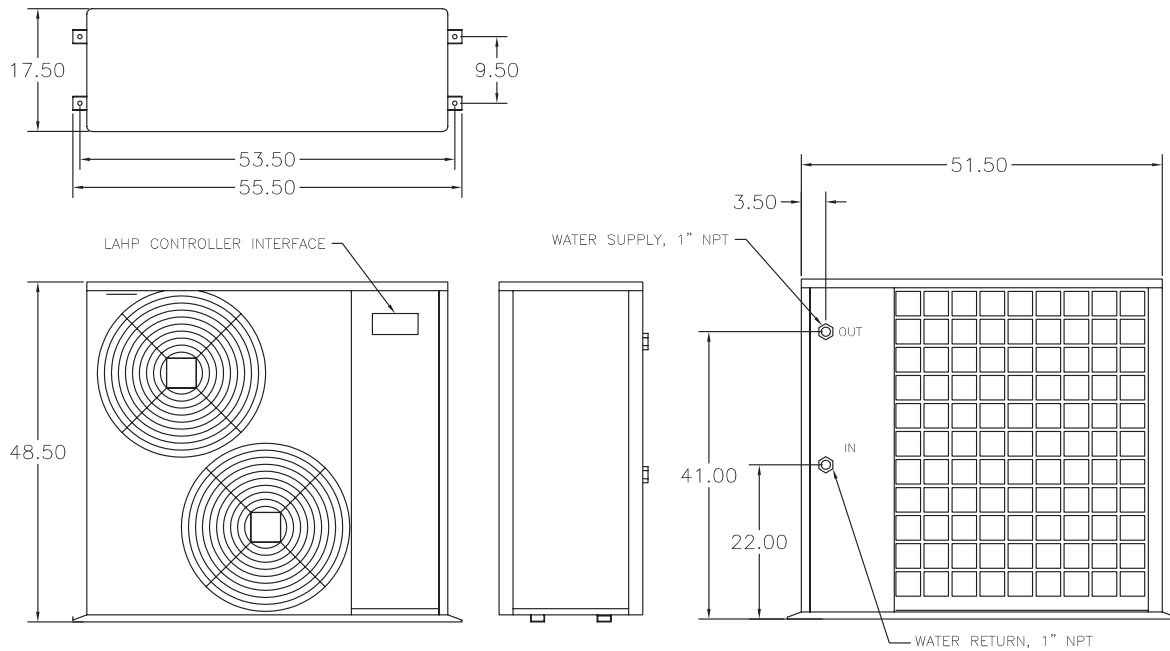

All dimensions in inches

SPL-WG077B

PERFORMANCE

LAHP Heating Operation

Supply Water Temp °F	Ambient Temp °F	Capacity BTU/hr	Water DP ft WC	Watts	COP
110	-5	37,500	17.1	3,880	2.30
	17	44,800	17.1	3,970	2.70
	47	60,580	17.1	4,263	3.75
120	-5	38,500	17.1	4,513	2.00
	17	46,440	17.1	5,790	2.35
	47	66,480	17.1	5,963	3.26
130	-5	40,425	17.1	5,249	1.86
	17	48,762	17.1	5,371	2.18
	47	69,804	17.1	5,768	3.04

LAHP Cooling Operation

Supply Water Temp °F	Ambient Temp °F	Capacity BTU/hr	Water DP ft WC	Watts	COP
42	70	41,100	17.1	4,298	2.80
	82	39,950	17.1	4,414	2.65
	95	38,800	17.1	4,897	2.32
44	70	42,500	17.1	4,190	2.97
	82	41,250	17.1	4,238	2.85
	95	40,000	17.1	4,820	2.43
47	70	44,600	17.1	4,240	3.08
	82	43,200	17.1	4,274	2.96
	95	41,800	17.1	4,708	2.60

All data based upon pure water @ 11.0 GPM

LAHP Heating Performance

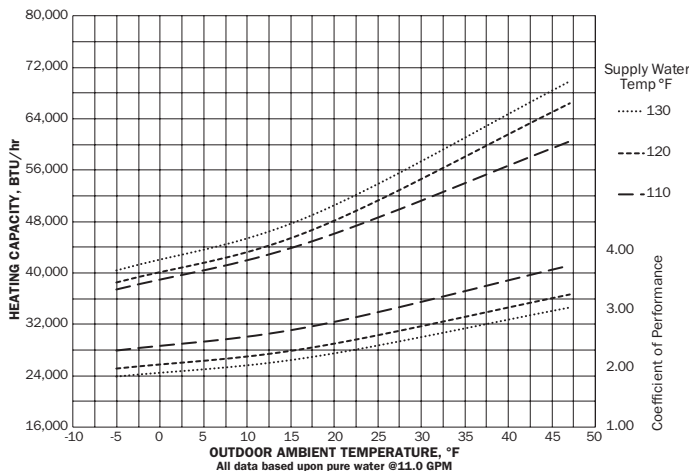

LAHP Cooling Performance

