



MODEL ESP-J & ESP-JV INSTALLATION, OPERATION & MAINTENANCE MANUAL

Central Air Conditioning Series
2 to 5 Tons
Fan Coil Unit/Air Supply
Components



SECTION 1: INTRODUCTION

SpacePak System Design.....	2
Code Compliance.....	2
Air Distribution Requirements.....	2
Model Number Description.....	2
Air Distribution Components.....	3-6
High Altitude Guidelines.....	6
Shipment of Unit.....	6

SECTION 2: SYSTEM INSTALLATION

Step 1: Locating The Unit.....	7
Step 2: Cutting Return Air Opening.....	10
Step 3: Attaching Supply Air Plenum Adaptor.....	10
Step 4: Setting The Unit.....	11
Step 5: Connecting Refrigerant Lines.....	12
Step 6: Installing The Condensate Trap & Line.....	13
Step 7: Wiring The Unit.....	13
Step 8: Installing Air Distribution Components.....	13-23
Step 9: Retrofit to B & C Series Units.....	22
Layouts.....	22-24

SECTION 3: START-UP & COMMISSIONING

Controls Overview.....	25
System Commissioning.....	26-32
Charging Cooling Only Systems.....	32
Factors Affecting the Balance of the System.....	32

SECTION 4: MAINTENANCE

Before Each Cooling Season.....	33
If System Fails To Operate.....	33
Troubleshooting Guide.....	34-37
Checking ESP-J Blower Motor.....	38
Check ESP-J Low Voltage Transformer.....	38
Check External Static Pressure.....	38
Service/Troubleshooting Form.....	39
Parts List.....	40,41
WARRANTY INFORMATION.....	42



IN UNITED STATES: 260 NORTH ELM ST. WESTFIELD, MA 01085 (413) 564-5530/FAX (413) 564-5815
 IN CANADA: 7555 TRANMERE DRIVE, MISSISSAUGA, ONTARIO, L5S 1L4 (905) 670-5888/FAX (905) 670-5782



Section 1: INTRODUCTION

The following terms are used throughout this manual to bring attention to the presence of potential hazards or to important information concerning the product:

▲ DANGER Indicates an imminently hazardous situation which, if not avoided, will result in death, serious injury or substantial property damage.

▲ WARNING Indicates an imminently hazardous situation which, if not avoided, could result in death, serious injury or substantial property damage.

▲ CAUTION Indicates an imminently hazardous situation which, if not avoided, may result in minor injury or property damage.

NOTICE: Used to notify of special instructions on installation, operation or maintenance which are important to equipment but not related to personal injury hazards.

SPACEPAK SYSTEM DESIGN

SpacePak is a hi-velocity central air conditioning system which utilizes a conventional outdoor condensing unit matched with the indoor Model ESP-J fan coil unit to provide conditioned air through the specially-designed, pre-fabricated, pre-insulated flexible duct system. The system and its basic components operate the same as in any conventional air-to-air cooling system.

The SpacePak system is covered by the following U.S. Patents: 3,507,354; 3,575,234; 3,596,936; 3,605,797; 3,685,329; 4,045,977; 4,698,982; 926,673 and Canadian Patents: 891,292; 923,935; 923,936.

CODE COMPLIANCE

Fan coil unit installation must conform to the requirements of the local authority having jurisdiction or, in the absence of such requirements, to the National Board of Fire Underwriters regulations. Fan coil unit meets ETL listing requirements.

All electrical wiring must be in accordance with the National Electrical Code ANSI/NFPA No. 70-latest edition and any additional state or local code requirements. If an external electrical source is utilized, the fan coil unit, when installed, must be electrically grounded.

NOTICE: It is a requirement of the International Mechanical Code (307.2.3) to install a secondary drain or an auxiliary drain pan where damage to any building components will occur as a result of overflow from the equipment drain pan or stoppage in the condensate drain piping from a cooling or an evaporator coil. Follow local code requirements.

AIR DISTRIBUTION SYSTEM COMPONENT REQUIREMENTS

Air distribution components installation must conform to the requirements of local authority having jurisdiction or, in the absence of such requirements, to the National Fire Protection Association 90A or 90B.

Do not begin the installation of the system without performing a load calculation to determine heat gain, system layout and material take-off. If a layout plan is not already available and room terminator requirements determined, then refer to the SpacePak Application Manual, SP9, to complete this information. A description of air distribution system components is shown in Figure 1.1.

ESP-J - MODEL NUMBER DESCRIPTION

1	2	3	4	5	6	7	8	9	10	11	12
UT			CA				SE	CT	RT	CF	RV

1,2,3 - Unit Type [UT]

ESP - Evaporator DX Fan Coil Unit

4,5,6,7 - Capacity [CA]

2430 - 24,000 to 30,000 BTU/Hr. (2-2½ tons)

3642 - 36,000 to 42,000 BTU/Hr. (3-3½ tons)

4860 - 48,000 to 60,000 BTU/Hr. (4-5 tons)

8 - Series [SE]

J - "J" series

9 - Cabinet Type [CT]

H - Horizontal

V - Vertical

10 - Refrigerant Type [RT]

4 - R410A

11 - Cabinet Feature [CF]

M - Modified

12 - Revision [RV]

A- Standard Control (blue board)

B-Advanced Control (black board)

FIGURE 1.1: AIR DISTRIBUTION SYSTEM COMPONENTS

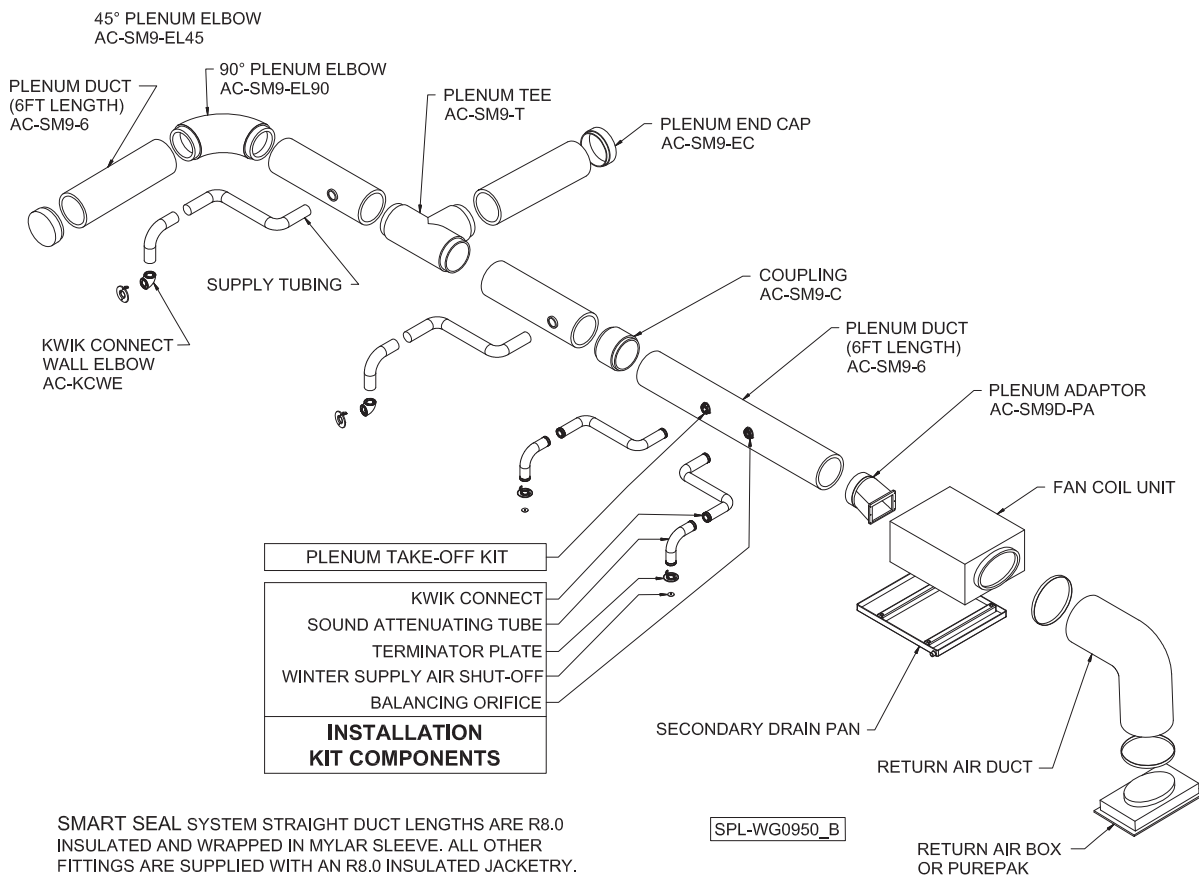

SMART SEAL SYSTEM STRAIGHT DUCT LENGTHS ARE R8.0 INSULATED AND WRAPPED IN MYLAR SLEEVE. ALL OTHER FITTINGS ARE SUPPLIED WITH AN R8.0 INSULATED JACKETRY. DUCT COMPONENTS SHOWN WITHOUT FACTORY SUPPLIED R8.0 INSULATED JACKETRY.

RETURN AIR BOX (BM-9149, AC-RBF-3, BM-9169): Each includes filter grill with metal frame, permanent filter, and 2 clamp bands. BM-9149 is for ESP-2430J. AC-RBF-3 is for ESP-3642J and BM-9169 is for ESP-4860J.

RETURN AIR DUCT (BM-6808-10, BM-6809-10, BM-6839-10): Flexible, 10 feet long with round shape. BM-6808-10 (15" dia.) for ESP-2430J. BM-6809-10 (19" dia.) for ESP-3642J and BM-6839-10 (24" dia.) is for ESP-4860J.

PLENUM ADAPTOR: 9" round OR 10" X 10" square metal component to attach plenum duct to fan coil unit.

PLENUM DUCT & COMPONENTS: May be 9" round sheet metal or 10" X 10" (O.D.) square, fiberboard duct types as specified by the installing contractor. Above layout is shown as an illustrative Smart Seal assembly reference only.

R6 SUPPLY TUBING (AC-ST6-100): Flexible, R6 insulated, 2" I.D. and 3-1/4" O.D. Each section is 100 feet long.

R8 SUPPLY TUBING (AC-ST8-75): Flexible, R8 insulated, 2" I.D. and 5-3/8" O.D. Each section is 75 feet long.

INSTALLATION KITS: Contains a specified amount of sound attenuating tubes, kwik-connects, terminator

plates (incl. spring clips & screws), winter supply air shut-offs and a balancing orifice set to complete installation of room outlets. Supplied in (2) [AC-IKLT-2] and (5) [AC-IKLT-5] outlet boxed quantities.

PLENUM TAKE-OFF KIT: Contains a specific amount of plenum take-offs, gaskets and fasteners to complete installation of room outlets. Take-offs available for round sheet metal or square fiberboard duct as specified by installing contractor. Supplied in (2) [AC-TKMR-2] and (5) [AC-TKMR-5] outlet boxed quantities for round sheet metal and (2) [AC-TKFS-2] and (5) [AC-TKFS-5] outlet boxed quantities for square fiberboard.

KWIK CONNECT 90° WALL ELBOW (AC-KCWE): To allow for wall terminations in 2" X 4" stud spaces.

SECONDARY DRAIN PAN: Specifically sized for SpacePak horizontal fan coil units. Constructed of durable polyethylene. Fan coil unit sets directly on top and can be installed with threaded rod.

PLIERS (SPC-72): To assure full setting of all clips (fasteners) in plenum take-off (not shown).

PLENUM HOLE CUTTER (SPC-71-10): To cut 2" hole in fiber board for plenum take-off installation (not shown).

FIGURE 1.2: AIR DISTRIBUTION SYSTEM COMPONENTS

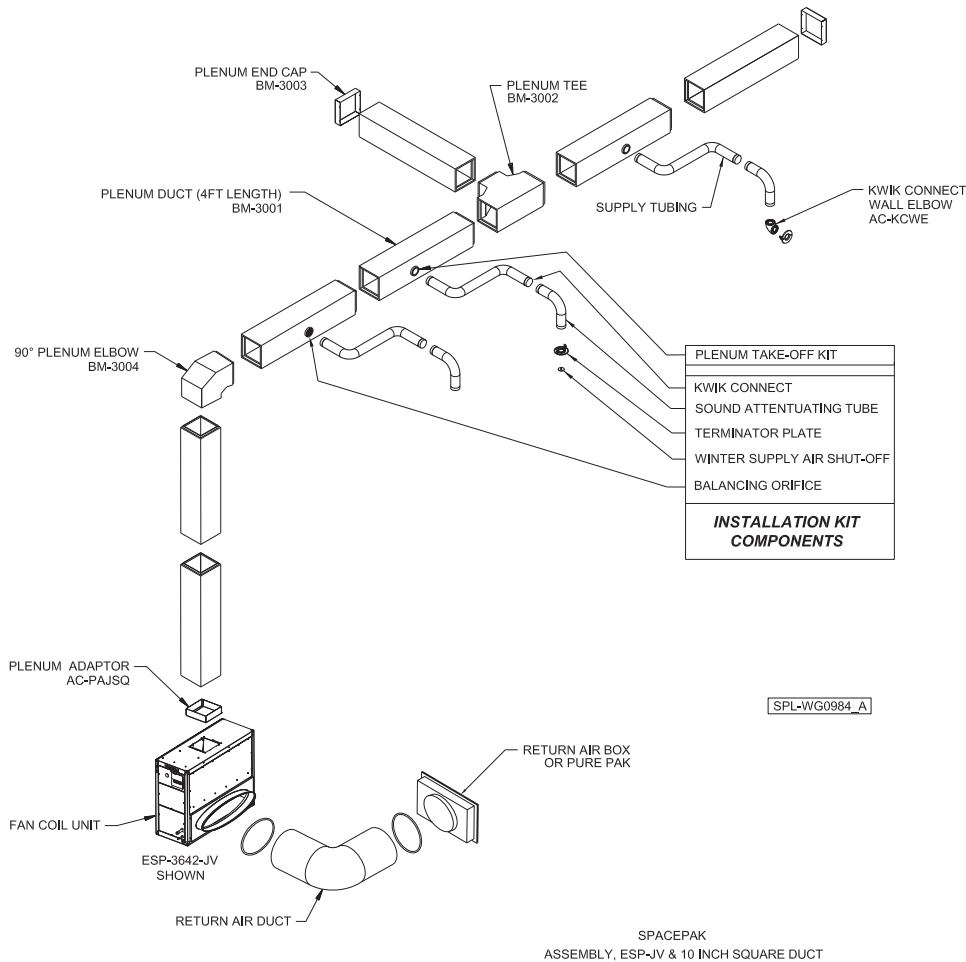

RETURN AIR BOX (SPC-1D, AC-RBF-3, SPC-3D): Each includes filter grill with metal frame, permanent filter, and 2 clamp bands. SPC-1D is for ESP-2430JV. AC-RBF-3 is for ESP-3642JV and SPC-3D is for ESP-4860JV.

RETURN AIR DUCT (SPC-4,5, & 6): Flexible, 10 feet long with round shape. SPC-4 (15" dia.) for ESP-2430JV. SPC-5 (19" dia.) for ESP-3642JV and SPC-6 (24" dia.) is for ESP-4860JV.

PLENUM ADAPTOR: 9" round OR 10" x 10" square metal component to attach plenum duct to fan coil unit.
 Plenum Adaptor - 9" Round - AC-PAJ
 Plenum Adaptor - 10" x 10" Square - AC-PAJSQ

PLENUM DUCT & COMPONENTS: May be 9" round sheet metal or 10" x 10" (O.D.) square, fiberboard duct types as specified by the installing contractor. Above layout is shown as an illustrative assembly reference only.

SUPPLY TUBING (SPC-25-100): Flexible, insulated, 2" I.D. and 3-1/4" O.D. Each section is 100 feet long.

R6 SUPPLY TUBING (AC-ST6-75): Flexible, R6 insulated, 2" I.D. and 5-3/8" O.D. Each section is 75 feet long.

R8 SUPPLY TUBING (AC-ST8-50): Flexible, R8 insulated, 2" I.D. and 6-1/4" O.D. Each section is 50 feet long.

INSTALLATION KITS: Contains a specified amount of sound attenuating tubes, kwik-connects, terminator plates (incl. spring clips & screws), winter supply air shut-offs and a balancing orifice set to complete installation of room outlets. Supplied in (2) [AC-IKLT-2] and (5) [AC-IKLT-5] outlet boxed quantities.

PLENUM TAKE-OFF KIT: Contains a specific amount of plenum take-offs, gaskets and fasteners to complete installation of room outlets. Take-offs available for round sheet metal or square fiberboard duct as specified by installing contractor. Supplied in (2) [AC-TKMR-2] and (5) [AC-TKMR-5] outlet boxed quantities for round sheet metal and (2) [AC-TKFS-2] and (5) [AC-TKFS-5] outlet boxed quantities for square fiberboard.

KWIK CONNECT WALL ELBOW (AC-KCWE): To allow for wall terminations in 2" x 4" stud spaces.

PLIERS (SPC-72): To assure full setting of all clips (fasteners) in plenum take-off (not shown).

PLENUM HOLE CUTTER (SPC-71-10): To cut 2" hole in fiber board for plenum take-off installation (not shown).

Plenum Duct

The plenum duct can be run in practically any location accessible for the attachment of the supply tubing (see suggested layouts in Figure 1.3). The plenum is normally located in the attic or basement, and it is usually more economical to run the plenum where it will appreciably shorten the lengths of two or more supply runs.

In some two-story split level homes, it may be advantageous to go from one level to another with the plenum duct. Whenever necessary, either between floors or along the ceiling, the small size of the plenum makes it easy to box in.

The fan coil unit is designed to operate with a total external static pressure of 1.8 inches of water column (minimum 1.2 - maximum 1.8). Excessive static pressure increases the air flow in individual runs and may cause some or all terminators to be noisy.

For systems designed with a bullhead tee installed as on Unit No. 1 (Figure 1.4), the best results are obtained if not more than 60% of the total number of system outlets are attached to any one branch of the tee. For systems with a branch tee installed as on Unit No. 2 (Figure 1.4), not more than 30% of the total number of system outlets should be attached to the perpendicular branch of the tee.

The ESP-4860JV has some additional plenum installation requirements that the smaller systems do not. This is due to the twin blower arrangement.

NOTE: For installations replacing B or C series units refer to retrofit instructions on page 22.

FIGURE 1.3: PLENUM/TUBING LAYOUT EXAMPLES (FOR GUIDANCE ONLY)

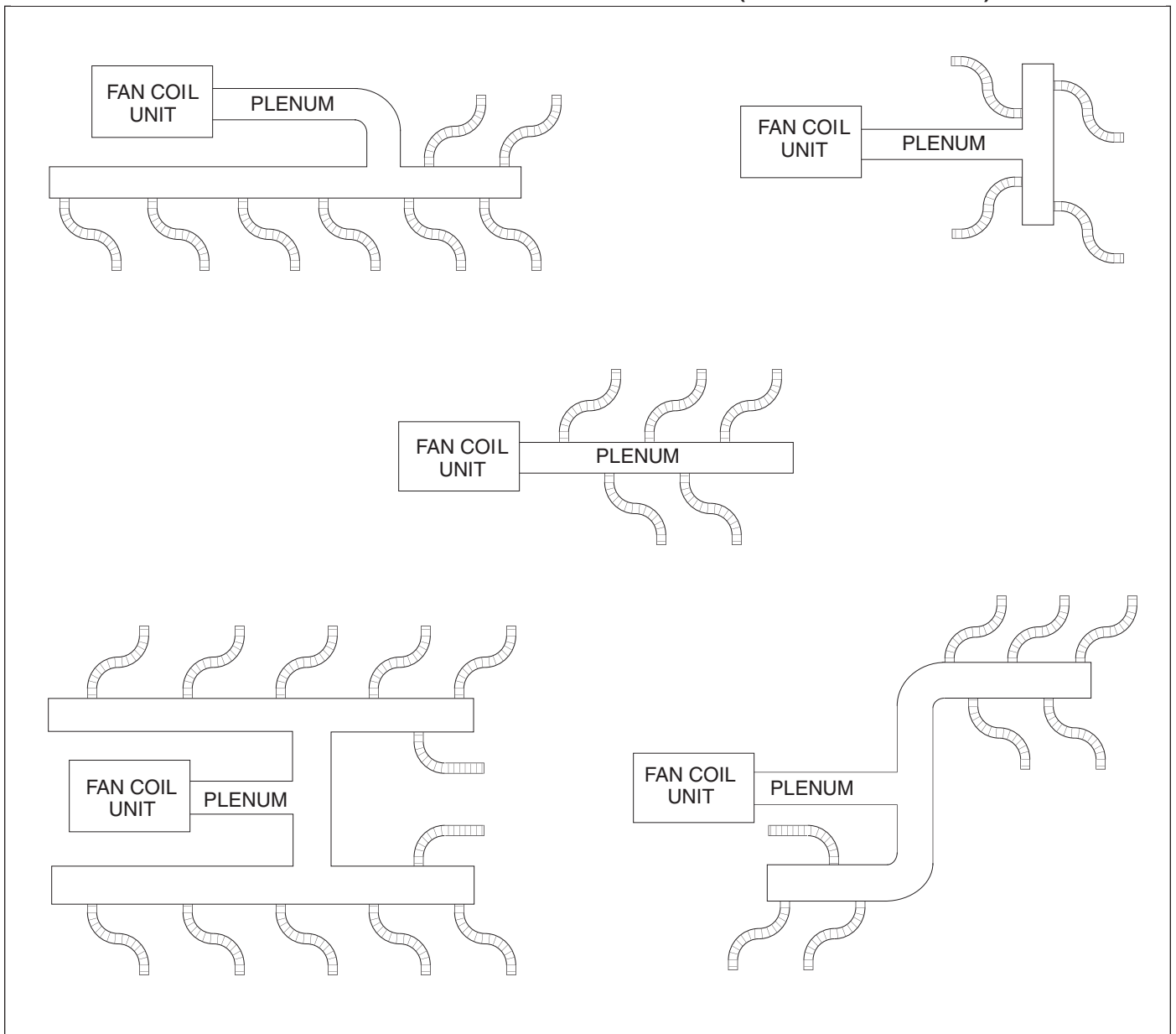
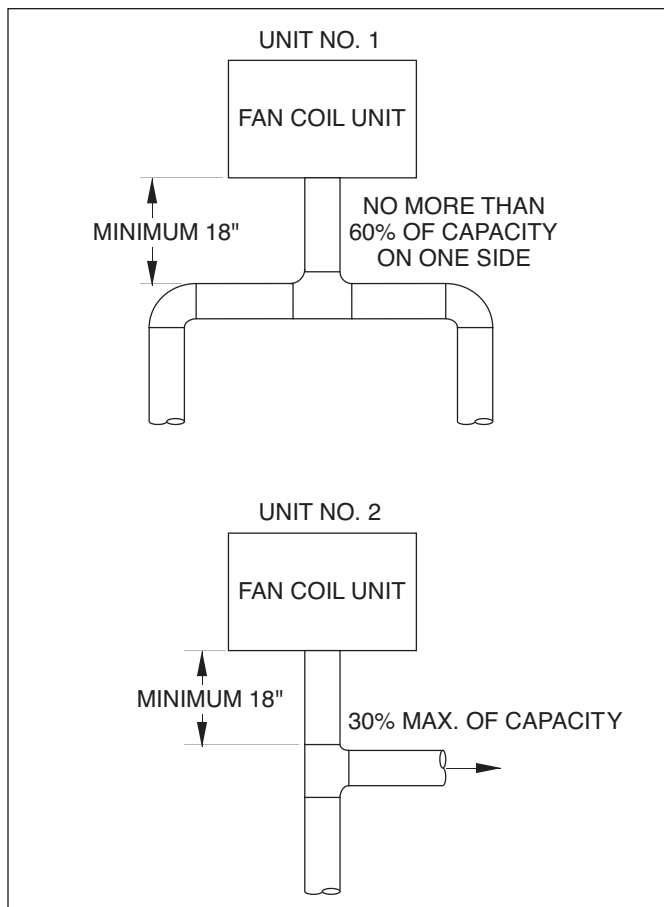

FIGURE 1.4: ESP-3642/4860J INSTALLATIONS



The larger system capacities (ESP-3642/4860J) are affected more by higher system static pressure than the smaller systems. Installation of the plenum tee closer than the minimum indicated in Figure 1.4 will reduce performance of the system. No supply runs should be installed between unit outlet and this tee. Static readings on system should be taken before tee.

Supply Tubing

In the case of two-story or split-level applications, supply tubing may run from one story to another. It is small enough to go in stud spaces, but this is often difficult in older homes because of hidden obstructions in stud spaces. It is more common to run the supply tubing from the attic down through second story closets to the first story terminators.

Supply tubing runs in the corners of the second story rooms can be boxed in and are hardly noticeable since overall diameter is only 3-1/4".

Room Terminators

Terminators should be located primarily in the ceiling or floor for vertical discharge or high on a wall for horizontal discharge. Installation of horizontally discharged terminators is assisted with the SpacePak 90° wall elbow (see page 19). Two excellent spots for horizontal discharge are in the soffit area above kitchen cabinets (see Figure 1.5) and in the top portion of closets (see Figure 1.6).

FIGURE 1.5: TERMINATOR IN SOFFIT AREA

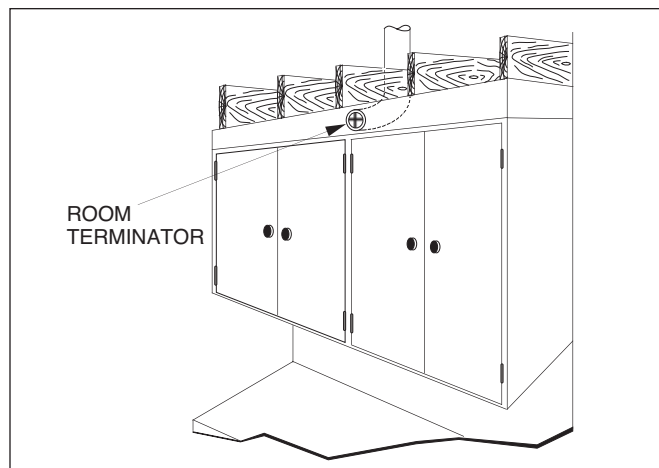
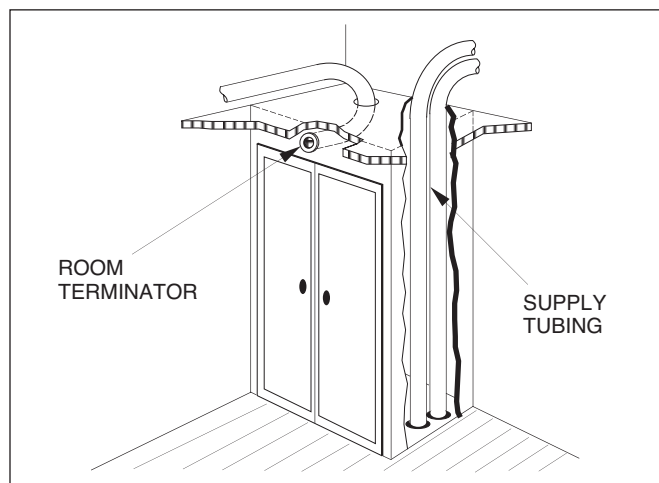

FIGURE 1.6: TERMINATOR IN CLOSET TOP AREA



Terminators should always be out of normal traffic patterns to prevent discharge air from blowing directly on occupants. And they should not be located directly above shelves or large pieces of furniture. Outside wall or corner locations are recommended if the room has more than one outside wall. Locating terminators away from interior doors prevents short cycling of air to the return air box.

SHIPMENT OF UNIT

Each fan coil unit is shipped in a single carton. Packed with the unit, there are vibration isolation pads, a condensate trap assembly and a factory installed primary float switch.

Each unit comes from the factory charged with nitrogen. When the unit is unsealed, a slight "pop" or "hissing" noise should be heard. This guarantees that the unit is properly sealed.

NOTICE: For high altitude systems use the following chart as a guideline for number of outlets.

ALTITUDE	MINIMUM NO. OF OUTLETS PER TON
5000 - 6500'	8
6500' and above	9

SECTION 2: SYSTEM INSTALLATION

NOTICE: Before proceeding with the installation, we recommend reading through this section of the manual for an overall understanding of the air conditioning fan coil unit and air distribution system component installation procedures.

Step 1: Locating the Unit

The fan coil unit may be installed in an unconditioned space (as long as it is protected from the weather) such as an attic, garage or crawlspace, or a conditioned space such as a basement, closet or utility room (see dimensions in Figures 2.2, 2.3 and 2.4).

When selecting a location, consider the location of the unit in relation to the return air box or filter box as shown in Figure 2.5. The return air duct should have at least one 90° bend to avoid unnecessary sound feedback to the living space from the fan coil unit.

When selecting a location, consider the layout of the plenum duct, supply tubing, refrigerant lines and condensate drain line.

When installing the unit above a finished ceiling or living space, install a secondary drain pan. Always follow local code requirements.

FIGURE 2.1: MODEL ESP-J SPECIFICATIONS

Model	System capacity (Nom. Tons)	Electrical Characteristics*	Connections				Recommended Condensing Unit	
			Suction Line (O.D.)	Liquid Line (O.D.)	Cond. Drain (FPT)	Return Inlet (Dia.)	Nominal Capacity (MBH)	Min SEER
ESP-2430J-V	2 - 2-1/2	230/60/1	7/8"	3/8"	3/4"	15"	24 to 30	13+
ESP-3642J-V	3 - 3-1/2	230/60/1	7/8"	3/8"	3/4"	19"	36 to 42	13+
ESP-4860J-V	4 - 5	230/60/1	7/8"	3/8"	3/4"	24"	48 to 60	13+

*Unit includes optional conversion kit to 115V.

Model	System capacity (Nom. Tons)	Blower				Coil		Ship. Wt. (lbs)	
		Std. CFM @ 1.2" W.C.	Wheel Dia. and Width	Motor HP	115V/230V F.L. Amps*	No. of Rows Deep	Flow Control Device	J	JV
ESP-2430J-V	2 - 2-1/2	440, 550	10" x 6"	3/4	5.6/2.8	6	TXV	105	135
ESP-3642J-V	3 - 3-1/2	660, 850	10" x 6"	3/4	7.6/4	6	TXV	123	170
ESP-4860J-V	4 - 5	880, 1150	10" x 6"	3/4	10.6/5.4	6	TXV	144	210

*Unit includes optional conversion kit to 115V.

FIGURE 2.2: UNIT DIMENSIONS AND CLEARANCES (inches)

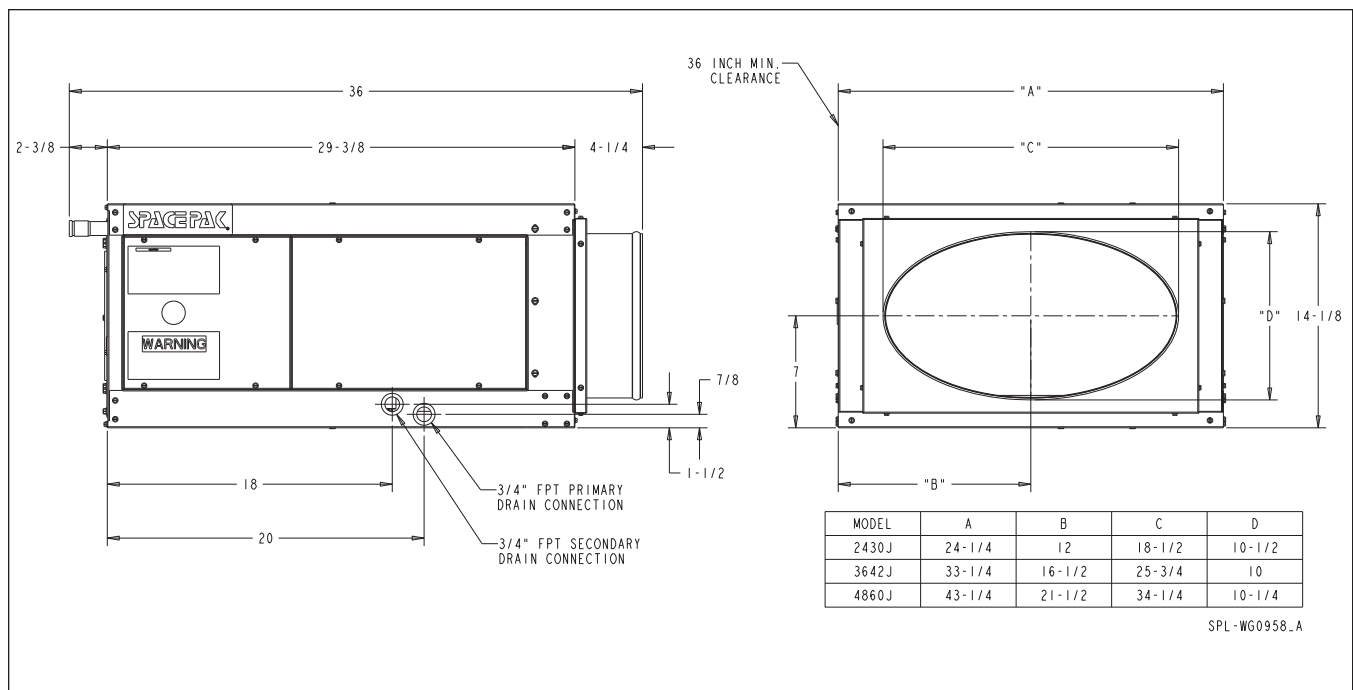

FIGURE 2.3: VERTICAL UNIT DIMENSIONS AND CLEARANCES (Inches)

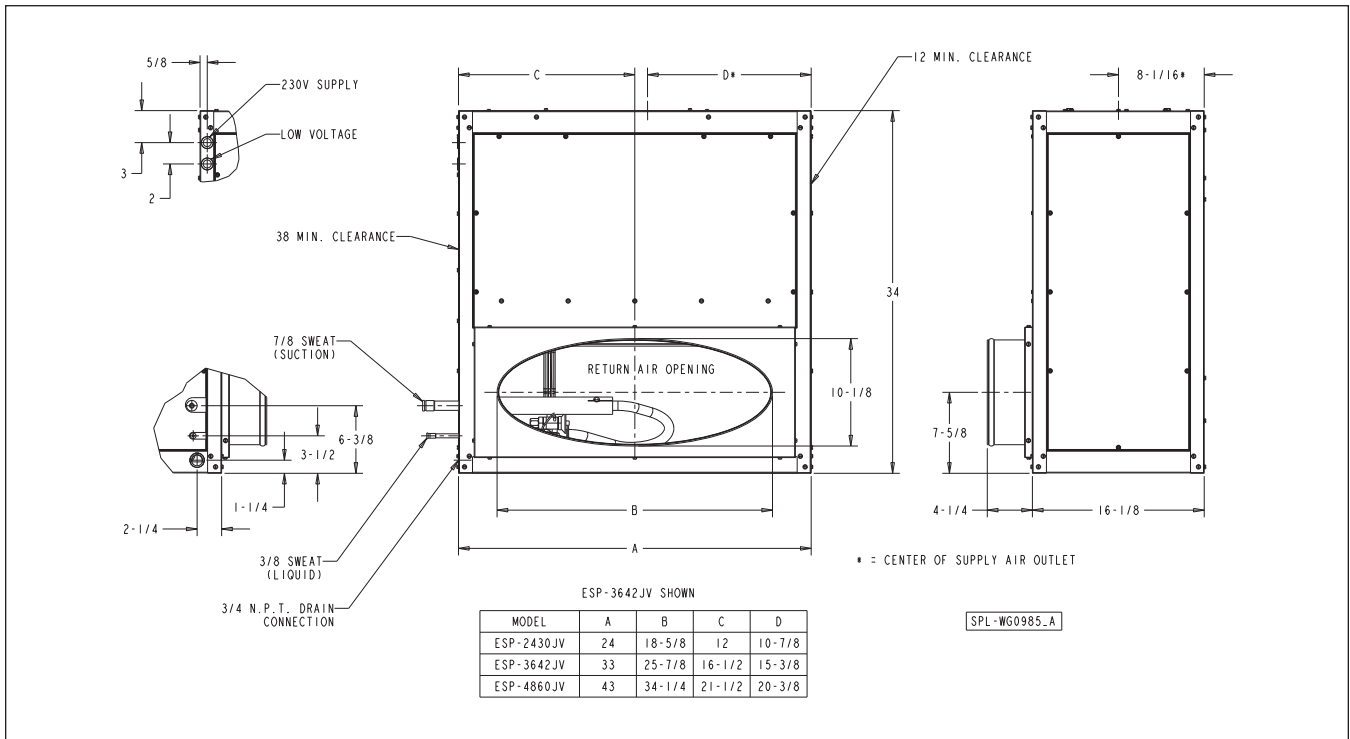

FIGURE 2.4: CONNECTION LOCATIONS AND ASSEMBLED PLENUM ADAPTOR DIMENSIONS

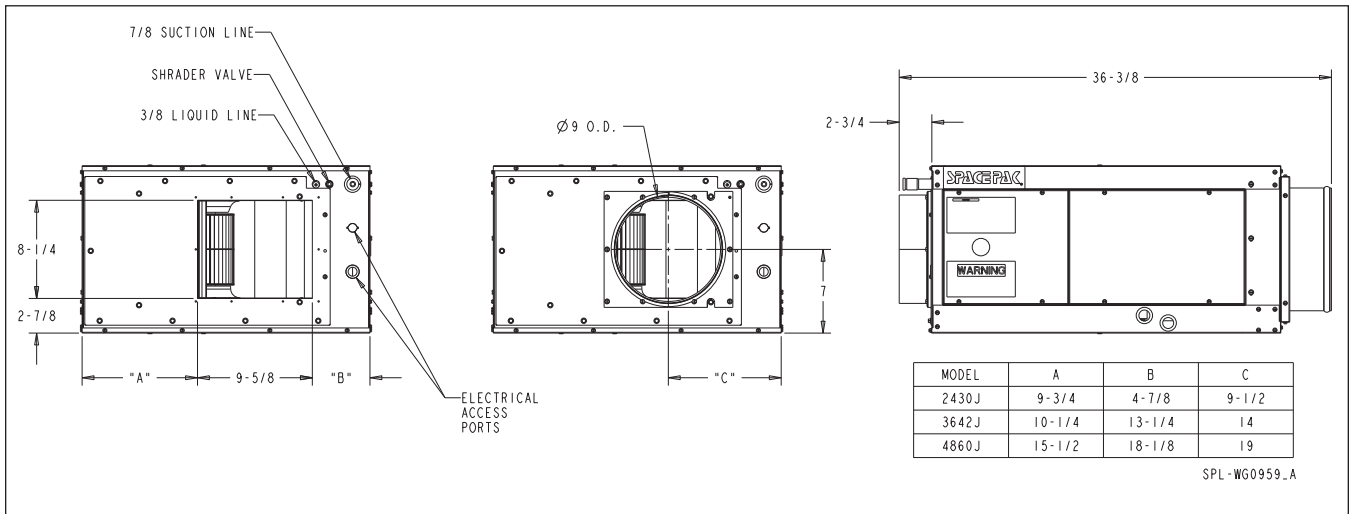

FIGURE 2.5: TYPICAL UNIT INSTALLATION

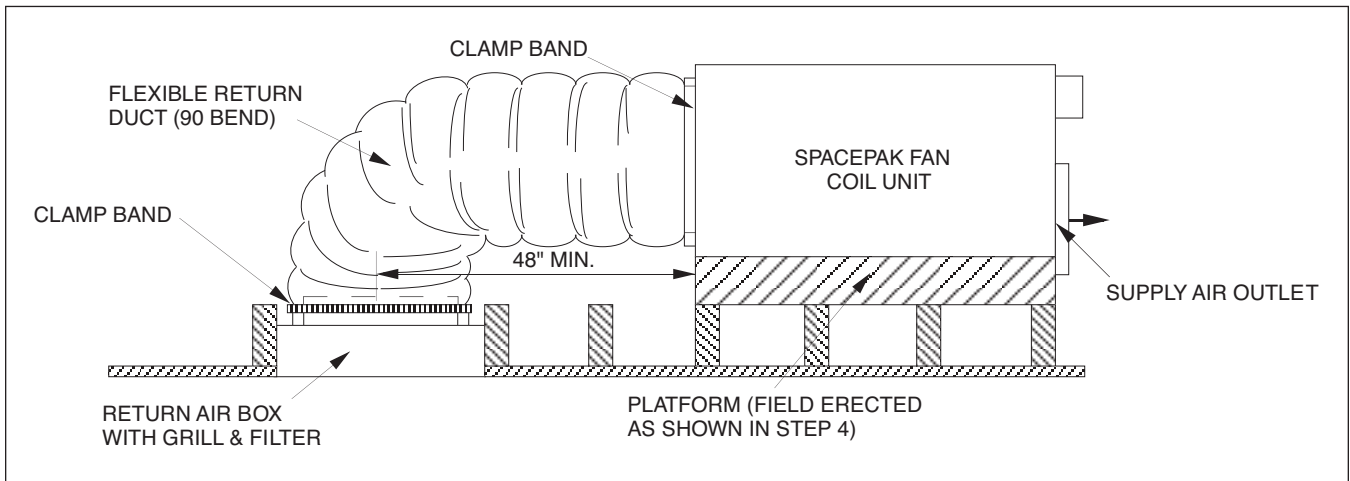

FIGURE 2.6: HORIZONTAL AIR FLOW UNIT INSTALLATION

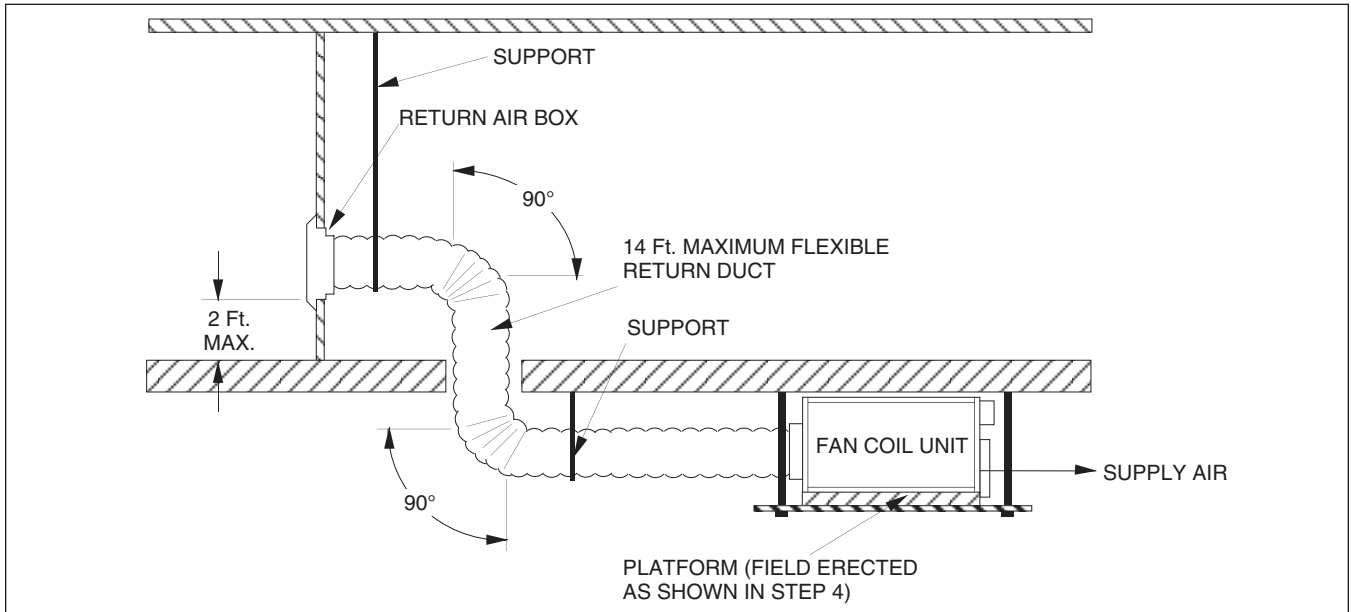

FIGURE 2.7: TYPICAL CLOSET/UTILITY ROOM INSTALLATION

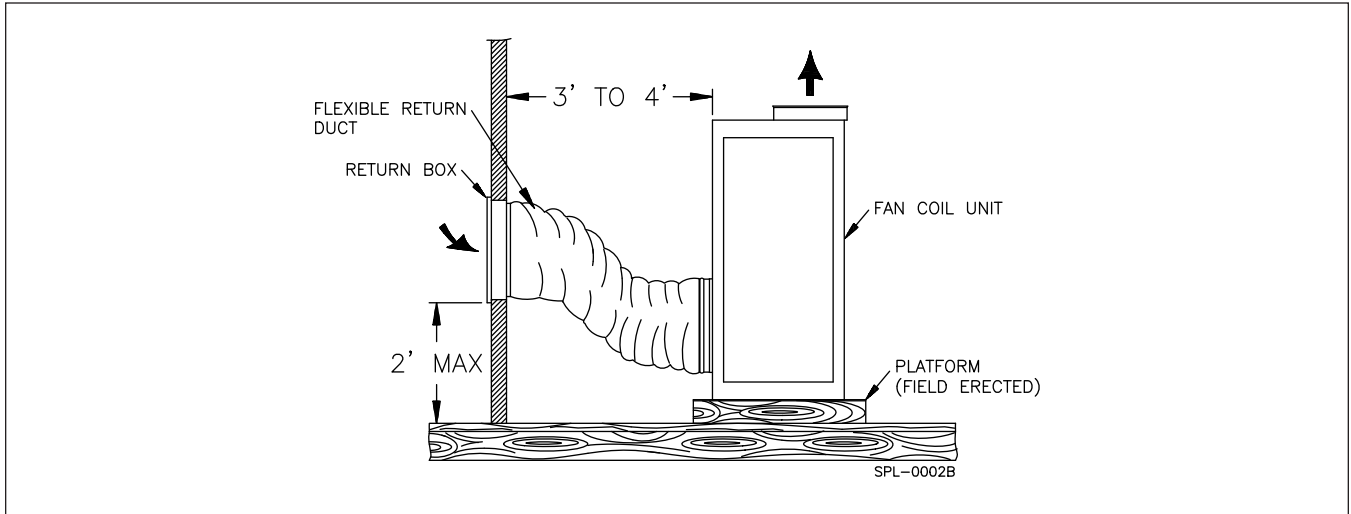
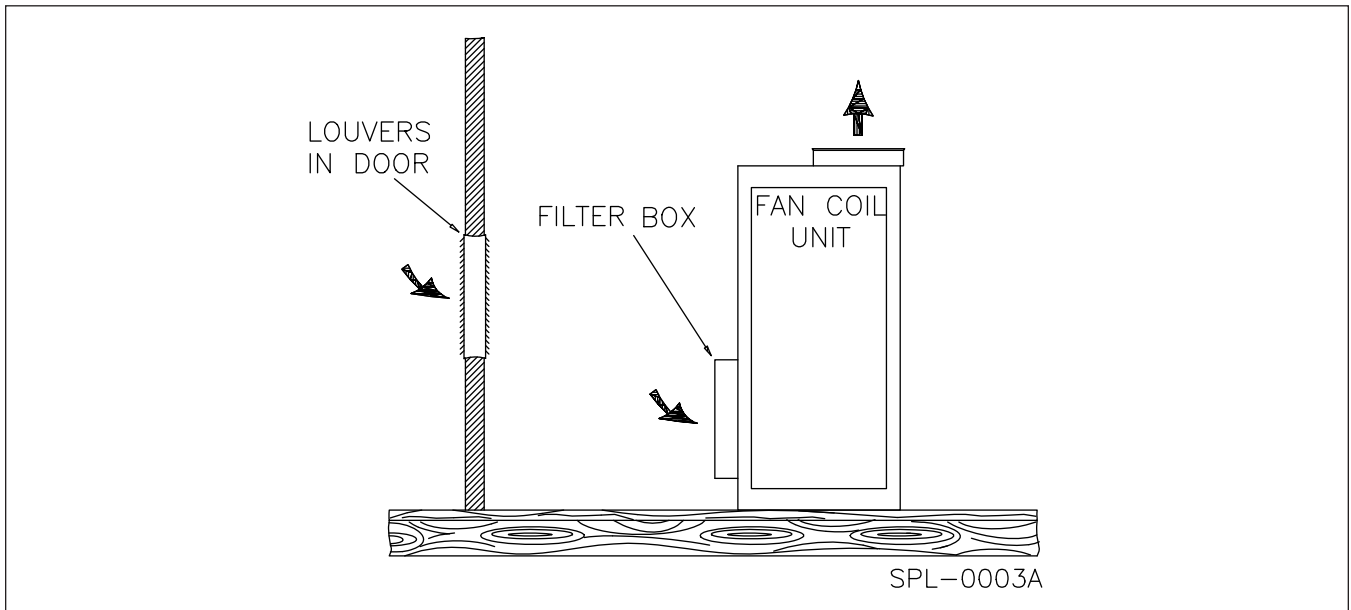

FIGURE 2.8: TYPICAL CLOSET INSTALLATION



Step 2: Cutting Return Air Opening

Select exact location for return air box. Avoid installing box in dining room, living room, kitchen, etc., unless return air duct can be installed with at least two 90° bends (accomplished by splicing two return air ducts together.)

For attic installations to raise fan coil unit up through opening, cut return air opening 14-1/2" wide by the "A" dimension (Figure 2.9) of appropriate unit size. These openings will accommodate the return air box with sufficient frame lip to cover the opening (see Figure 2.9).

NOTICE: The return air adapter may need to be removed from the unit to fit through the opening cut-out.

If joists are on 16" centers, the 14-1/2" width of the return air box should fit between successive joists. Where joists run in the opposite direction, or to properly center the return, it may be necessary to cut joists and install headers.

For all wall return applications, cut the return air opening to accommodate the return air box according to the same dimensions. Remember, location of opening must allow for a 90° bend in the return air duct.

Check the opening for proper fit of the return air box. Do not install the return air box until the installation of the entire SpacePak system is completed, if you want to fit materials up through this hole.

Step 3: Attaching Supply Air Plenum Adaptor

NOTICE: If unit is to be located in the attic and installed through ceiling joists, attach supply plenum adaptor in attic.

A. HORIZONTAL DISCHARGE:

Refer to Figure 2.11 and duct installation instructions supplied with fan coil unit.

NOTICE: Allow space on sides for servicing.

FIGURE 2.9: RETURN AIR BOX FRAME DIMENSIONS

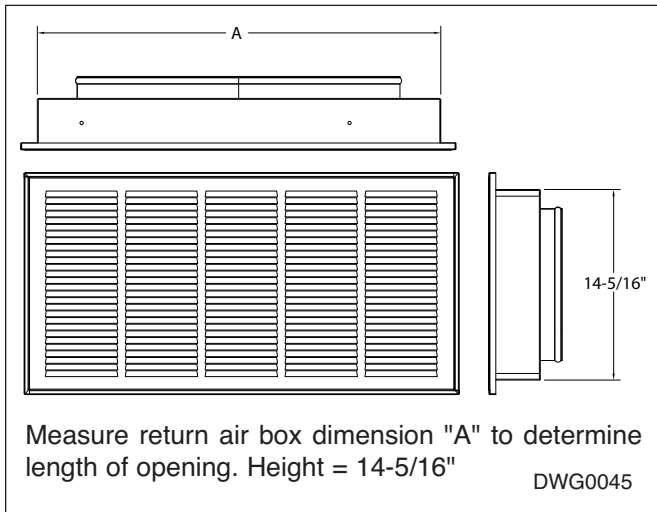

FIGURE 2.10

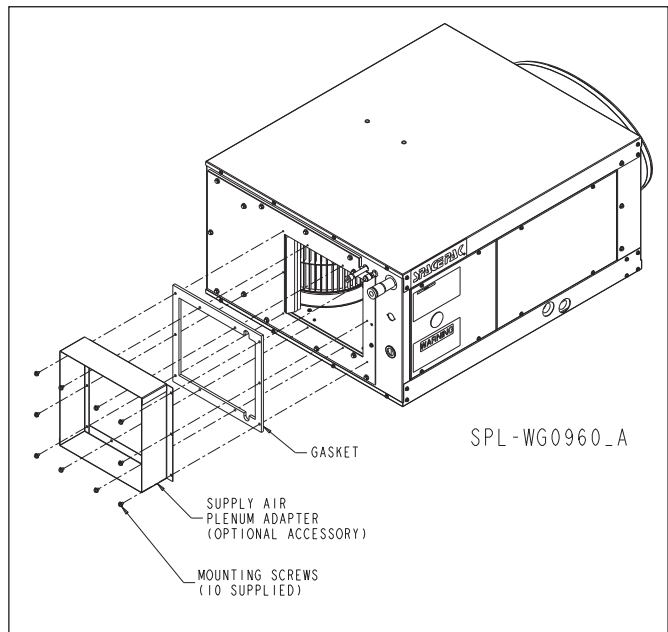
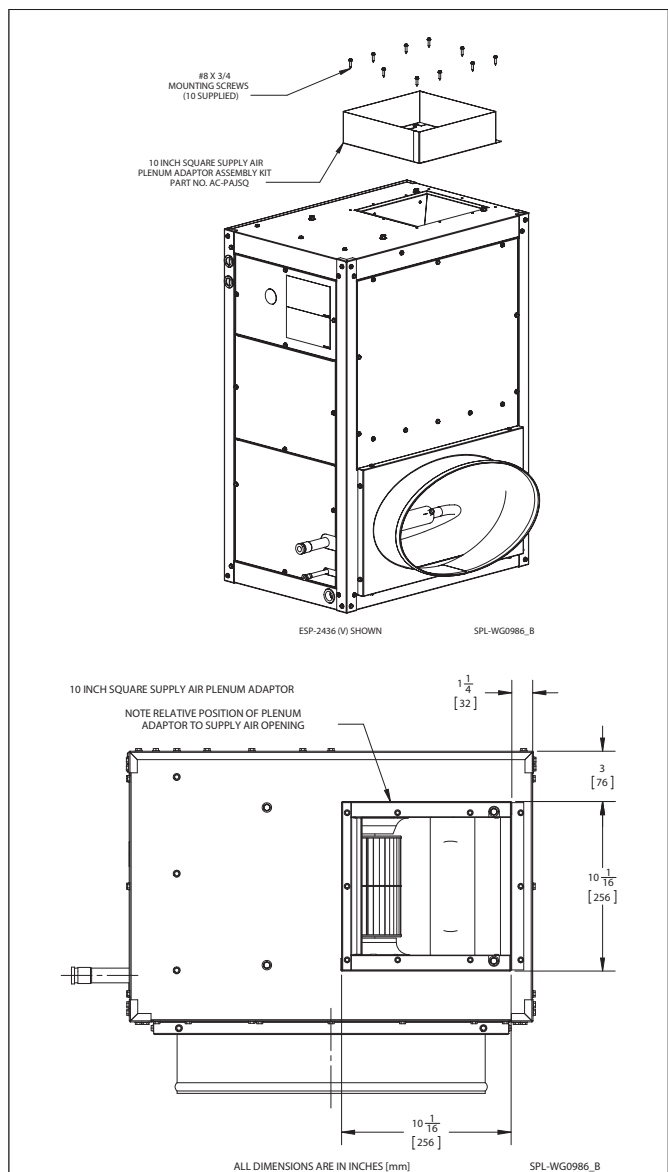

FIGURE 2.11: PLENUM ADAPTOR ASSEMBLY



Step 4: Setting the Unit

Construct a platform for the fan coil unit, as shown in Figure 2.13. The platform can be constructed of 2 x 4 x 4 (minimum), 2 x 6, 2 x 8 and 2 x 10 lumber, as necessary to achieve proper pitch of 1/4" per foot for the condensate drain line. Figure 2.12 shows the approximate normal allowable run of condensate piping as a function of the framing lumber used for platform construction. The platform covering should be 1/2" plywood minimum.

Attach vibration isolation pads (supplied inside fan coil unit) to platform covering as shown in Figure 2.13.

Secure the platform to the joist or floor, depending on location selected for the fan coil unit. Make sure platform is level.

For locations where the fan coil unit will be suspended, suspend platform from overhead by 1/4" threaded rods.

NOTICE: Allow room on sides for servicing.

For installations with a return air box and return air duct, set fan coil unit on the platform with the elliptical opening facing in the direction of the return air box. **DO NOT** let the supply air plenum adaptor support the weight of the unit.

Do not secure the unit to the platform, as the weight of the unit will hold it in position.

FIGURE 2.12: CONDENSATE PIPING RUNS

LUMBER SIZE	2 X 4	2 X 6	2 X 8	2 X 10
MAXIMUM HORIZONTAL	8'	16'	24'	32'

FIGURE 2.13: MOUNTING PLATFORMS SHOWN WITH VIBRATION ISOLATION STRIPS

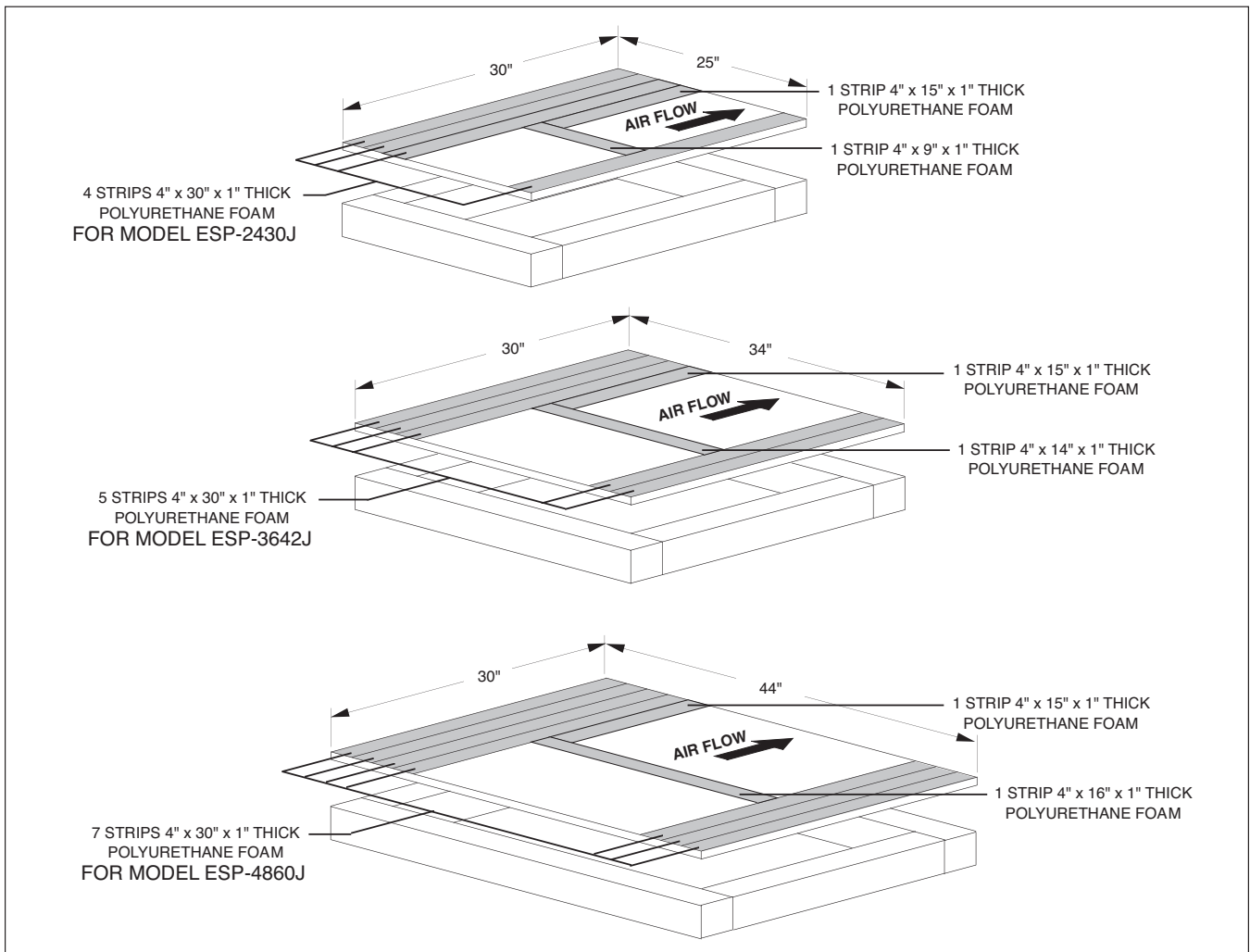
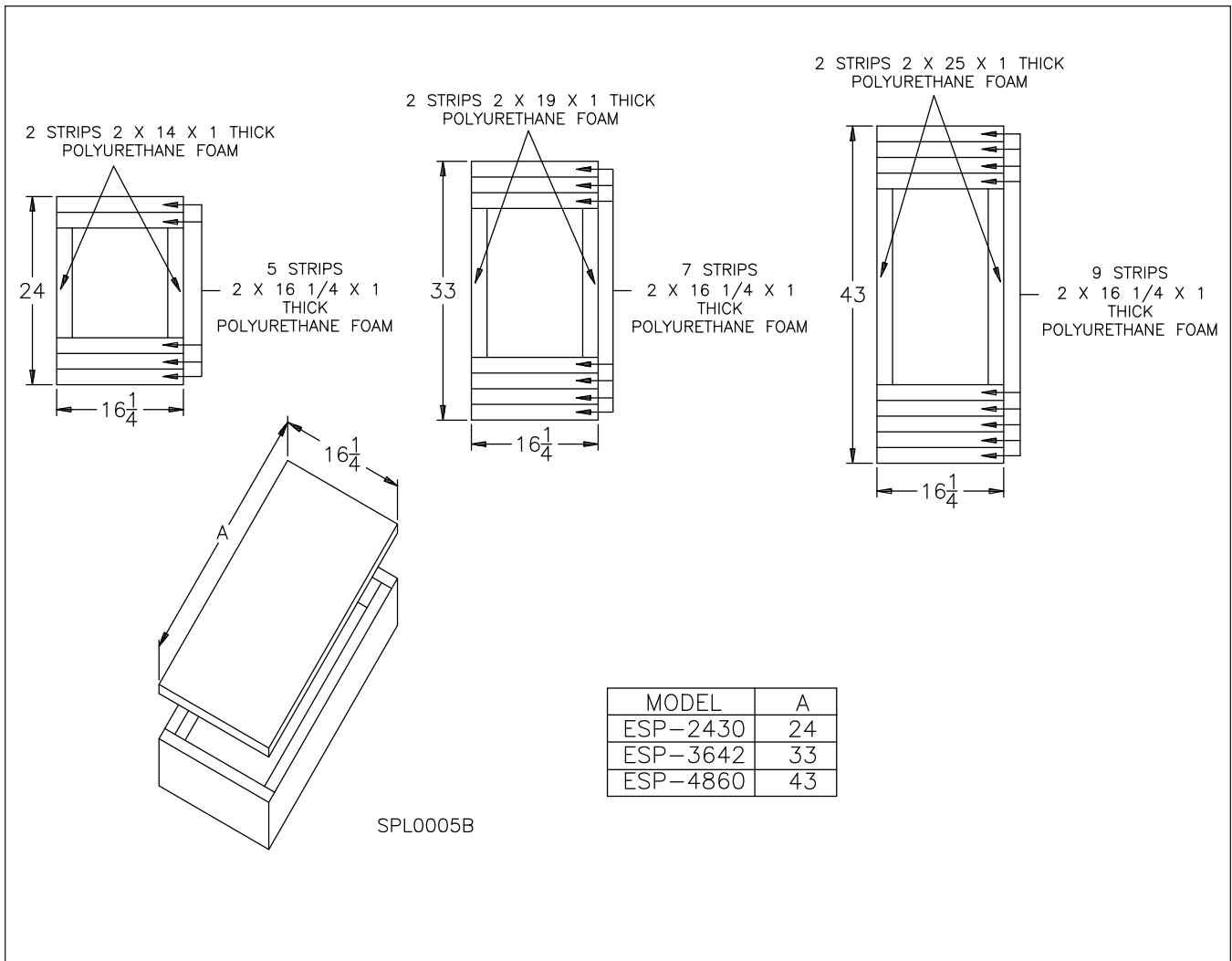

FIGURE 2.14: MOUNTING PLATFORMS FOR VERTICAL INSTALLATIONS



Step 5: Connecting Refrigerant Lines

Connect refrigerant lines from the outdoor condensing unit to the fan coil unit in accordance with its manufacturer's sizing recommendations for the length of the piping run. Proper line sizing is critical to the operation of the system. Always use proper brazing procedures. A

trickle flow (2PSI) of dry nitrogen to avoid scale or blockage in the piping system is recommended while brazing. SpacePak also recommends installing a sight glass on the liquid line outside of the unit as an aid for accurately charging the system.

Step 6: Installing the Condensate Trap & Line

NOTICE: It is a requirement of the International Mechanical Code (307.2.3) to install a secondary drain or an auxiliary drain pan where damage to any building components will occur as a result of overflow from the equipment drain pan or stoppage in the condensate drain piping from a cooling or an evaporator coil. Follow local code requirements.

Refer to Figure 2.2 and 2.3 for primary and secondary condensate drain locations. Components for the PVC condensate trap are provided in a separate bag with fan coil unit (see Figure 2.15) and should be cemented together with PVC pipe cement.

CAUTION Do not use substitute trap. Do not cut off or alter trap components.

Thread male adapter (see Figure 2.9) into unit's primary condensate drain connection. Assemble and cement remaining components together. Then cement assembly to male adapter. The 45° elbow provides an offset from beneath unit suction line for access to clean-out plug.

Run a condensate line from the trap to a suitable drain that's in accordance with local codes. Make sure the line is pitched 1/4" per foot.

NOTICE: The secondary drain connection requires field supplied components to complete installation. Follow local code requirements.

NOTICE: Never connect condensate line to a closed drain system.

FIGURE 2.15: CONDENSATE TRAP ASSEMBLY

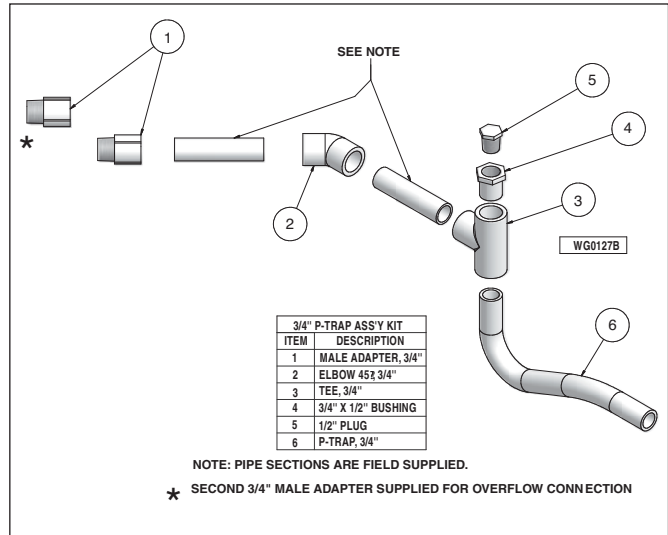

Step 7: Wiring the Unit

WARNING Turn off electrical power supply before servicing. Contact with live electric components can cause shock or death.

All electrical and control wiring must be installed in accordance with the codes listed in Section 1 of this manual. Standard wiring diagram is provided in Figure 2.16. Optional wiring diagrams are provided in Figures 2.17-2.20. A separate 230/60/1 power supply is recommended for the unit. Use standard 15-amp circuit breaker and 14-gauge wire from power supply to unit.

Connect power supply to Terminals L1 and L2 on the high voltage terminal block. Connect a ground wire to the equipment ground terminal located next to the high voltage terminal block.

Locate the room thermostat on a wall near the return air box, between 40" to 48" from the floor. Connect the low-voltage thermostat wiring from the room thermostat to the low voltage control block in the unit.

Connect low voltage from air handler to condensing unit as shown in figure 2.16.

Alternately, the unit may be configured to run on 115V, 60 Hz power. Refer to wiring diagram section.

Step 8: Installing Air Distribution Components

All plenum duct and supply tubing runs as well as room terminator locations must be in accordance with air distribution system requirements listed in Section 1 of this manual. Where taping of joints is required, UL181 approved tape is required.

Plenum Duct Installation

All tees, elbows and branch runs must be a minimum of 18" from the fan coil unit or any other tee, elbow or branch run.

Keep all tees and elbows to a minimum to keep system pressure drop on larger layouts to a minimum.

NOTICE: Refer to duct installation instructions supplied with fan coil unit or follow manufacturers instructions supplied with other duct system types.

FIGURE 2.16: MODEL ESP-J 230V STANDARD WIRING DIAGRAM*

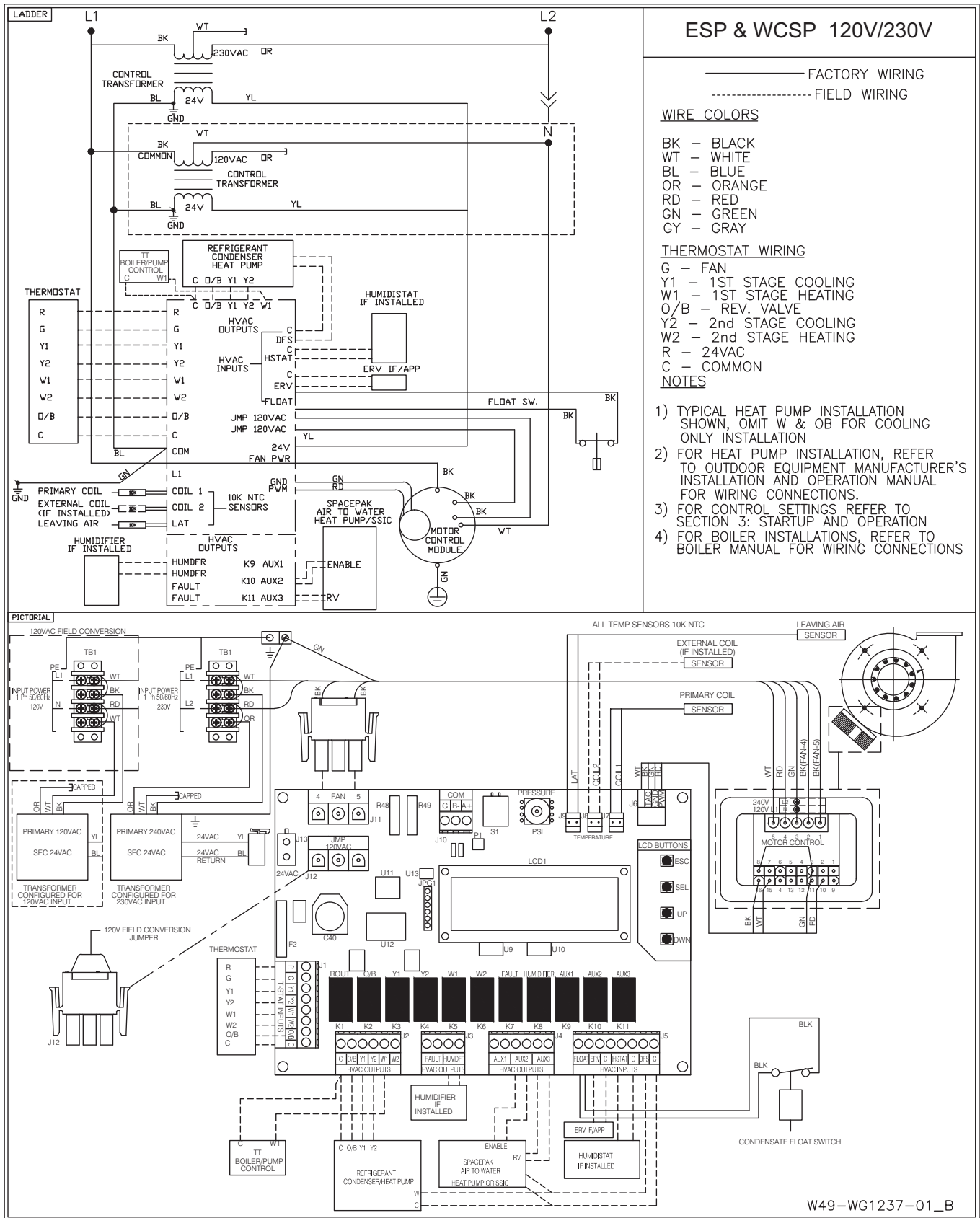

ESP & WCSP 120V/230V

————— FACTORY WIRING
 - - - - - FIELD WIRING

WIRE COLORS

- BK - BLACK
- WT - WHITE
- BL - BLUE
- OR - ORANGE
- RD - RED
- GN - GREEN
- GY - GRAY

THERMOSTAT WIRING

- G - FAN
- Y1 - 1ST STAGE COOLING
- W1 - 1ST STAGE HEATING
- O/B - REV. VALVE
- Y2 - 2nd STAGE COOLING
- W2 - 2nd STAGE HEATING
- R - 24VAC
- C - COMMON

NOTES

- 1) TYPICAL HEAT PUMP INSTALLATION SHOWN, OMIT W & OB FOR COOLING ONLY INSTALLATION
- 2) FOR HEAT PUMP INSTALLATION, REFER TO OUTDOOR EQUIPMENT MANUFACTURER'S INSTALLATION AND OPERATION MANUAL FOR WIRING CONNECTIONS.
- 3) FOR CONTROL SETTINGS REFER TO SECTION 3: STARTUP AND OPERATION
- 4) FOR BOILER INSTALLATIONS, REFER TO BOILER MANUAL FOR WIRING CONNECTIONS

W49-WG1237-01_B

FIGURE 2.17: SINGLE STAGE AIR CONDITIONING ONLY WIRING DIAGRAM

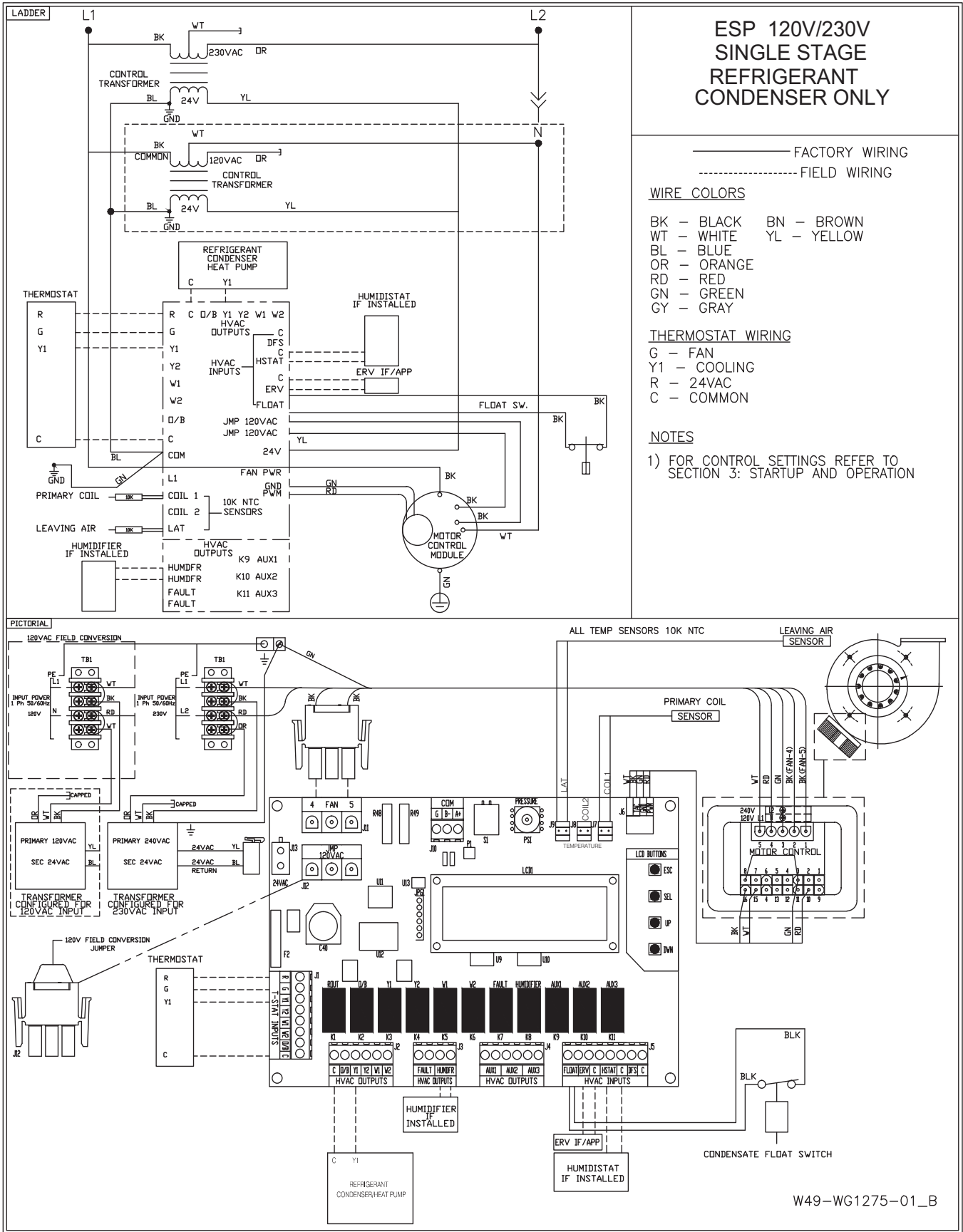
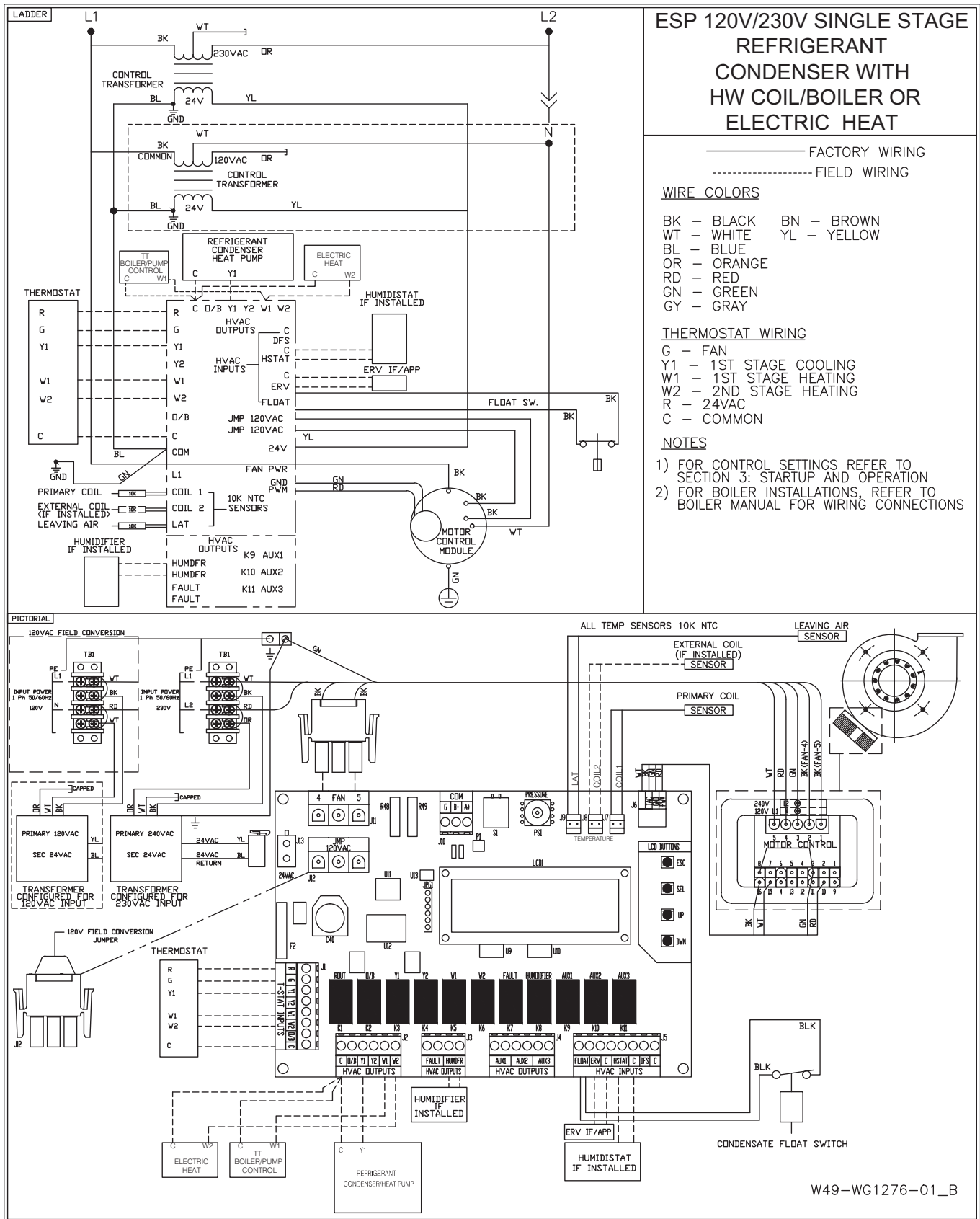

FIGURE 2.18: SINGLE STAGE AIR CONDITIONING WITH HW COIL WIRING DIAGRAM



ESP 120V/230V SINGLE STAGE REFRIGERANT CONDENSER WITH HW COIL/BOILER OR ELECTRIC HEAT

————— FACTORY WIRING
 - - - - - FIELD WIRING

WIRE COLORS

- BK - BLACK
- WT - WHITE
- BL - BLUE
- OR - ORANGE
- RD - RED
- GN - GREEN
- GY - GRAY
- BN - BROWN
- YL - YELLOW

THERMOSTAT WIRING

- G - FAN
- Y1 - 1ST STAGE COOLING
- W1 - 1ST STAGE HEATING
- W2 - 2ND STAGE HEATING
- R - 24VAC
- C - COMMON

NOTES

- 1) FOR CONTROL SETTINGS REFER TO SECTION 3: STARTUP AND OPERATION
- 2) FOR BOILER INSTALLATIONS, REFER TO BOILER MANUAL FOR WIRING CONNECTIONS

W49-WG1276-01_B

FIGURE 2.19: TWO STAGE HEAT PUMP/AC WIRING DIAGRAM

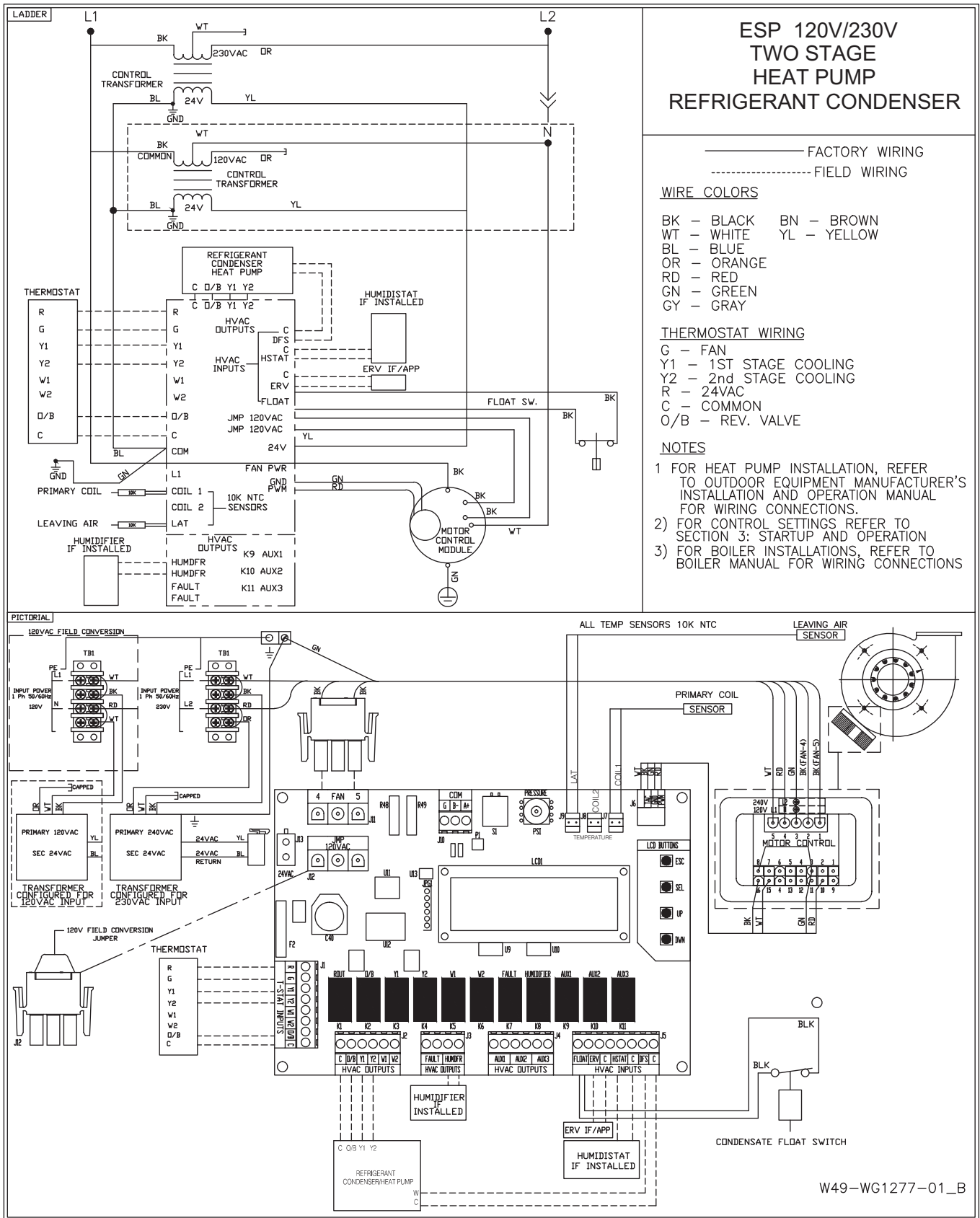

FIGURE 2.20: TWO STAGE HEAT PUMP/AC WITH BACKUP BOILER HEAT WIRING DIAGRAM

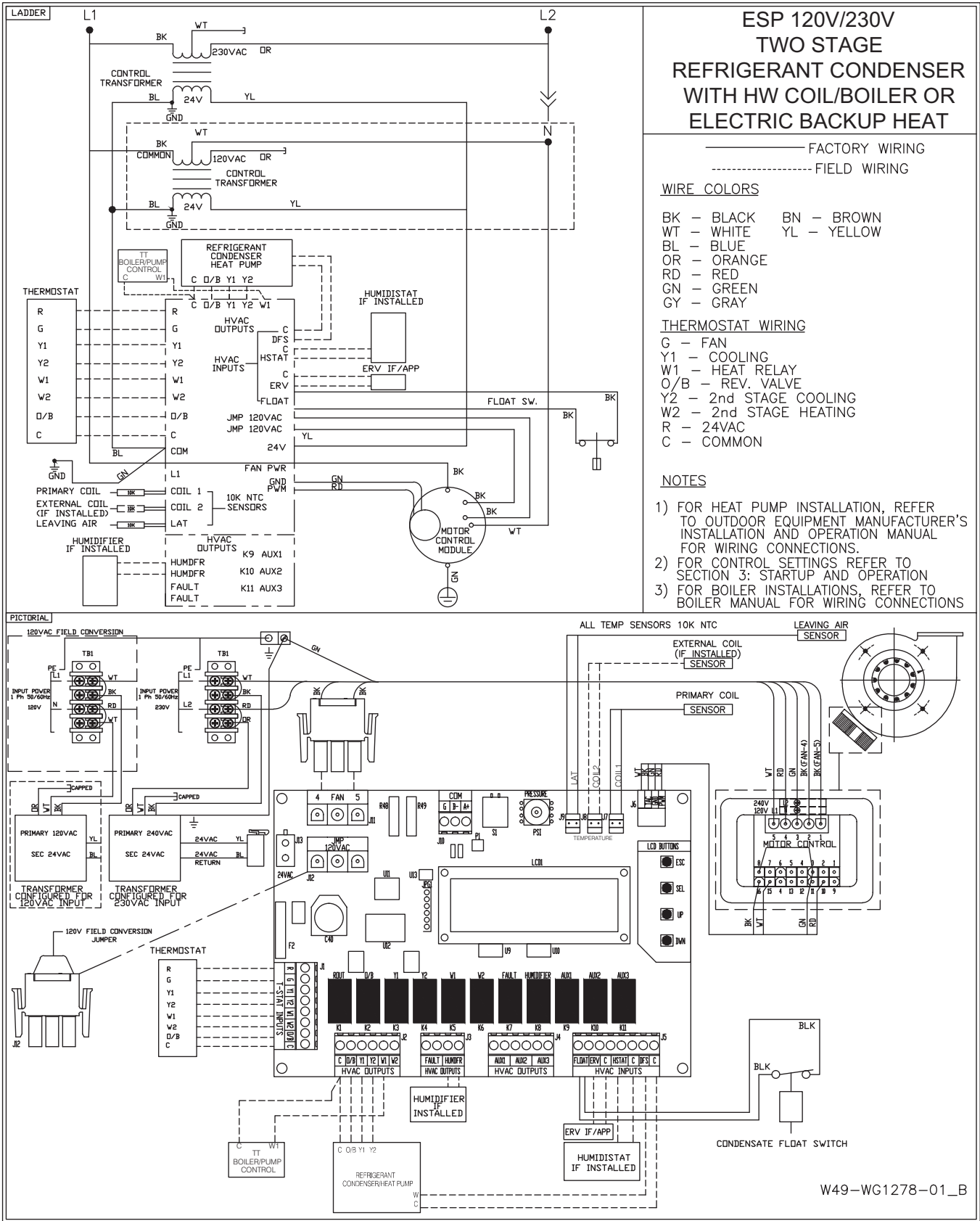
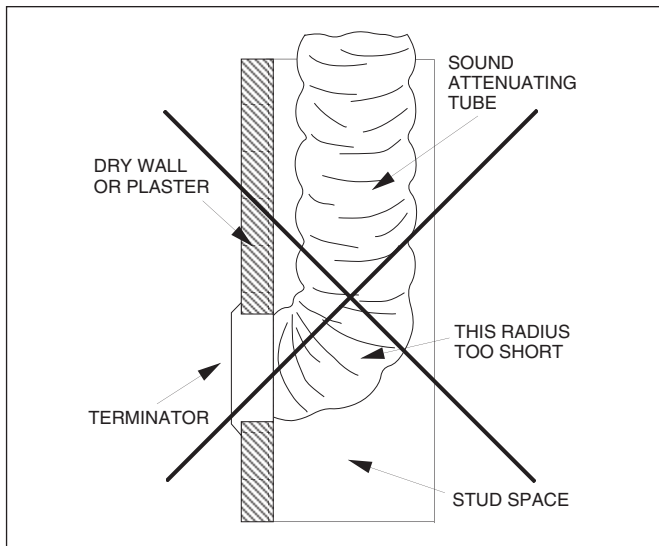

FIGURE 2.23: INCORRECT TUBING INSTALLATION



Room Terminator & Sound Attenuating Tubing Installation

Room terminators and pre-assembled sound attenuating tubes are provided in the Installation Kits.

NOTICE: Do not install terminators in a wall in which a sharp bend in the sound attenuating tube is required (see Figure 2.23). The result would be unacceptable noise.

OPTION: Using a SpacePak Kwik Connect Wall Elbow (Model Number: AC-KCWE) addresses this condition (see Figure 2.24).

FIGURE 2.24: INSTALLATION WITH KWIK CONNECT WALL ELBOW

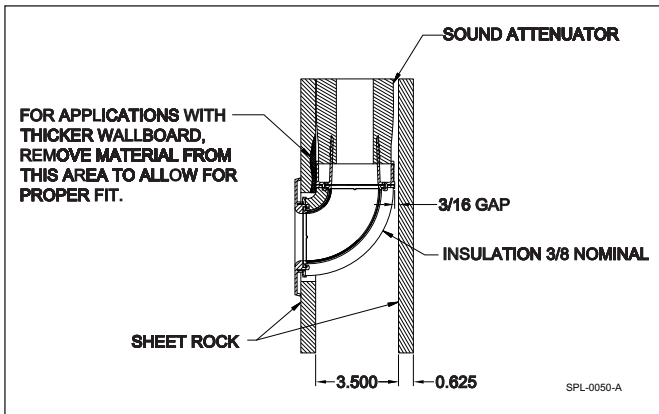

In marking location for room terminator (see Figure 2.25), the center of the terminator should be approximately 5" from the wall or, when installed in the corner of a room 5" from both walls.

After marking location, drill a 1/8" diameter hole for outlet. Verify there is at least 2" for tubing assembly clearance all around this hole by visual inspection or inserting a bent piece of wire to feel for obstructions. Adjust direction of hole as needed, to gain this 2" clearance. After all clearances have been checked, take a 4" diameter rotary-type hole saw and cut a hole, using the 1/8" diameter hole as a pilot.

FIGURE 2.25: TERMINATOR MEASUREMENTS

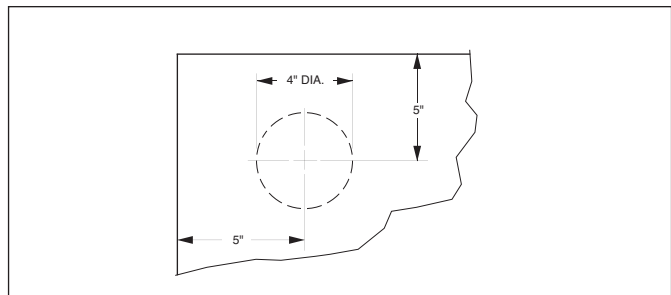

Assemble spring clips to terminator plate with screws provided in installation kit. Tighten clips until they are close to the thickness of the material they are being mounted to.

Assemble the room terminator to the sound attenuating tubing by simply fitting the two pieces together and twisting until tight (see Figure 2.24). If the terminator is to be used in a floor location, then field fabricate a small screen (1-1/2" square; 1/4 X 1/4 20-gauge galvanized wire screen) and place screen over opening on the back of the terminator prior to twisting on the kwik-connect (on the sound attenuating tube).

NOTICE: Do not shorten sound attenuating tube length. The result would be unacceptable noise.

Push the free end of the sound attenuating tube through the 4" hole until the two toggle springs on the room terminator snap into place.

Center the two spring clips on a line parallel to the direction of the tubing routing from the room terminator (see Figure 2.26). This is important since the weight of the tubing will have a tendency to cause a part of the terminator to pull away from the ceiling if the clips and tubing do not run parallel.

Then tighten the screws (attached to the terminator) until the terminator is snug against the ceiling or floor. **Do not overtighten.** For installations with floors or ceilings which are thicker than normal, longer toggle screws or special mounting plates may be required.

FIGURE 2.26: POSITIONING ROOM TERMINATOR

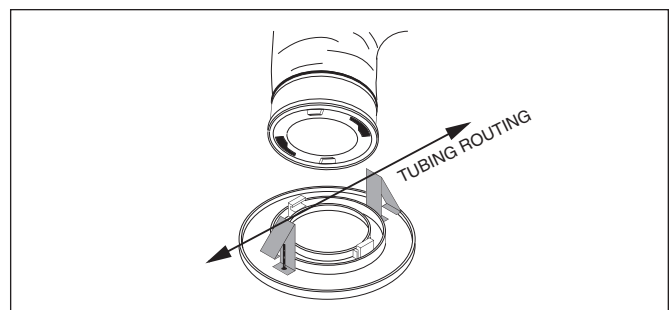

Supply Tubing Installation

Kwik-connects and balancing orifices are provided in the Installation Kits. Plenum take-offs, gaskets and fasteners are supplied in the separate plenum take-off kit.

Avoid sharp bends in the supply tubing (as well as the sound attenuating tubing). The minimum radius bend is 4" (see Figure 2.27); however, wherever possible, hold to a larger radius.

FIGURE 2.27: MINIMUM TUBING BEND

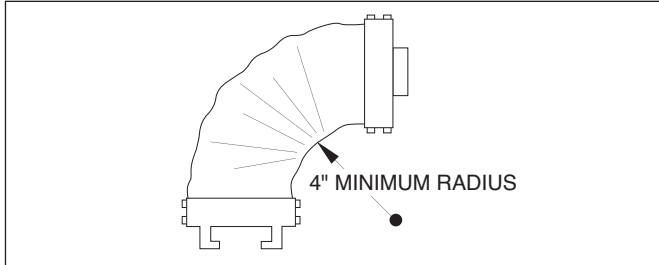

At the plenum, all supply tubing connections must be a minimum of 18" from any plenum tee, plenum elbow or the fan coil unit.

Individual supply tubing runs must be a minimum of 6-feet, even if the distance between the sound attenuating tubing and plenum is less than 6 feet.

R6 Supply tubing comes in 100-foot sections (R8 tubing comes in 75-foot sections) and may be cut to length with a knife or fine tooth hacksaw.

For each supply tubing run, estimate and cut the length of tubing that will be needed between the plenum and sound attenuating tube. At the open end of the supply tubing a kwik-connect will be installed (see Figure 2.28). First, push back the cover and the insulation exposing approximately 4" of the inner core. Fold in any tails or frays that may be present after cutting the supply tubing. Second, hand compress the corrugations until they are densely compacted 1-1/2" to 2" from the open end of the supply tube. Third, thread kwik-connect into the inner core until snug. Fourth, pull the insulation and cover forward and tuck it into the deep groove on the back side of the kwik-connect. Fifth, wrap the connection securely with UL181 approved tape.

FIGURE 2.28: KWIK-CONNECT INSTALLATION

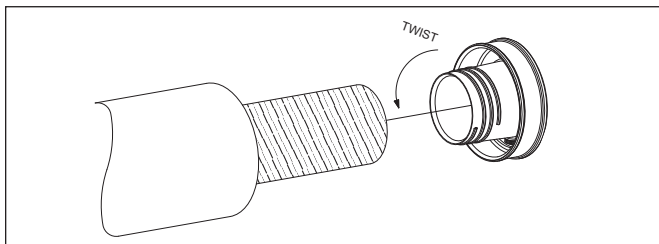

When finished, simply twist together (see Figure 2.29) the kwik-connect on the sound attenuating tube, and wrap the connection securely with tape.

After attaching the supply tubing to the sound attenuating tube, bring the open end of the tube to the plenum.

To cut a hole in the plenum, refer to duct installation instructions supplied with fan coil unit. Sheet metal duct requires a 2-1/16" hole.

FIGURE 2.29: CONNECTING TUBING

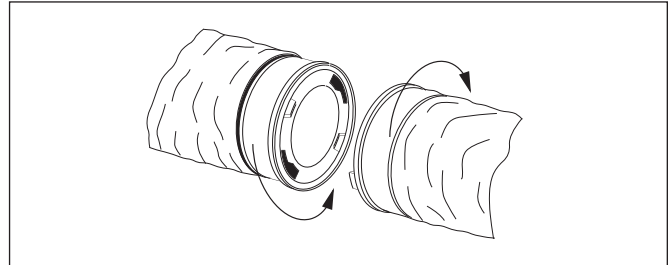

Remove the hole cut-out from the plenum. Make sure there is no "flap" left inside plenum that could block hole during operation.

Place the plenum take-off gasket on the back side of the plenum take-off and insert the assembly into the hole in the plenum (see Figure 2.30).

FIGURE 2.30: TAKE-OFF INSTALLATION

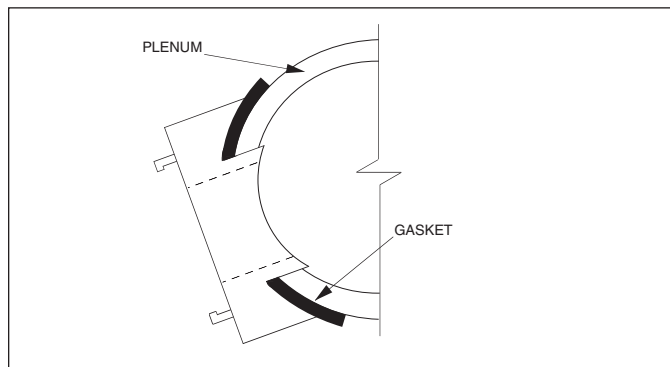

NOTICE: Gasket must be installed to seal plenum take-off to prevent air leakage.

Position the plenum take-off to match the curvature of the plenum duct. Hand insert the four plenum take off fasteners one at a time such that each clip reaches the interior of the duct. Using the SpacePak pliers, snap the fasteners into place until they lock in place (see Figure 2.31).

NOTICE: All four fasteners must be installed to assure air tight fitting between plenum take-off and plenum.

FIGURE 2.31: PLENUM TAKE-OFF FASTENER INSTALLATION

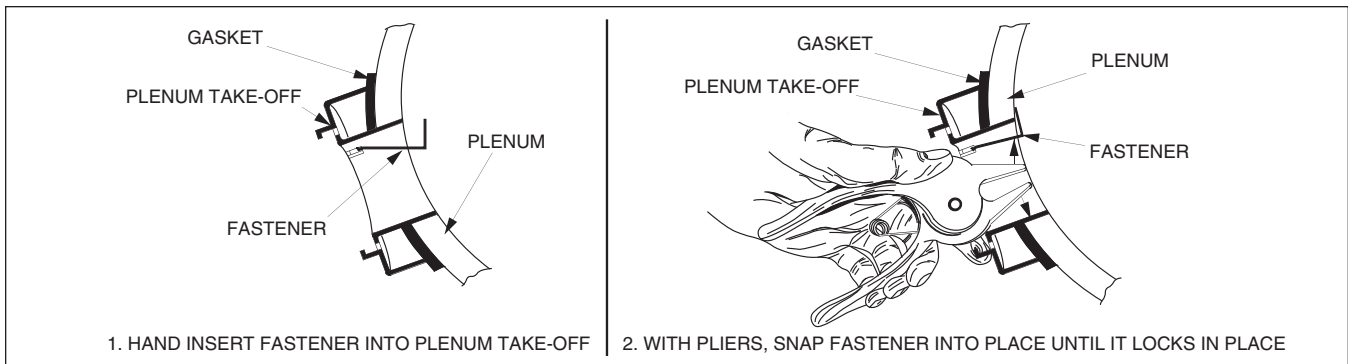

In accordance with your calculations as to requirements for balancing orifices, mount the orifice in the outlet of the plenum take-off (see Figure 2.32), prior to attaching the supply tubing.

Next, install a kwik-connect in the open end of the supply tubing, using the same procedures as before, and twist together kwik-connects on supply tubing and plenum take-off. Wrap connection securely with tape.

FIGURE 2.32: ORIFICE INSTALLATION

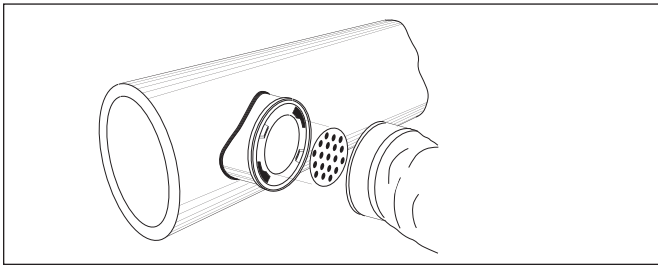

Return Air Box & Duct Installation

Remove the return air grill from the return air box and remove the air filter from the return air grill.

Insert the return box from below for ceiling installation (or from the front for wall installations) and fasten with four screws through holes provided on the long side of the box. (see Figure 2.33).

FIGURE 2.33: RETURN AIR BOX INSTALLATION

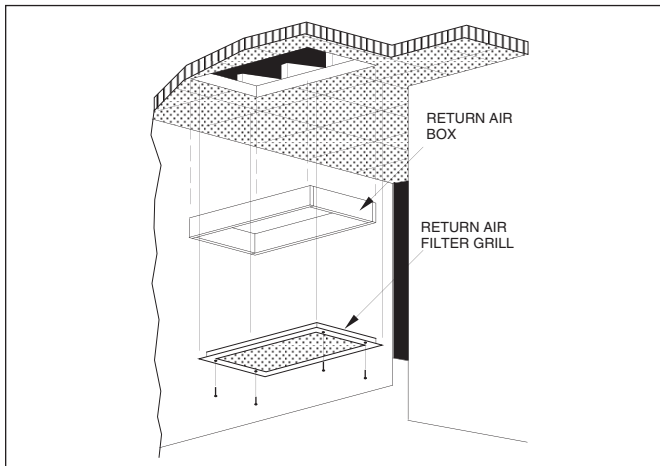

Remove the grill and the filter from the grill frame. Insert the frame into the box and mount in place with the screws provided through a hole at each corner of the frame. Finally, place the air filter into the frame and replace the grill. Turn the latches a quarter turn to lock the grill in place.

Slide a clamp band (provided with return air box) over one end of the return air duct. Place that end over the elliptical flange on the fan coil unit (see Figure 2.34). Move the clamp over the flange and tighten so the clamp holds the return air duct securely to the flange. Follow the same procedures to attach the return air duct to the return air box (see Figure 2.34).

FIGURE 2.34: RETURN AIR DUCT INSTALLATION

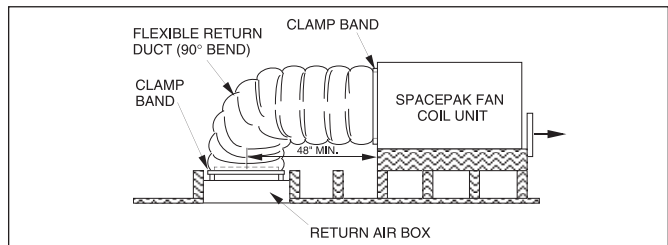

Return Air Box & Duct Installation

Remove the return air grill from the return air box and remove the air filter from the return air grill.

Insert the return box from below for ceiling installation (or from the front for wall installations) and fasten with four screws through holes provided on the long side of the box. (see Figure 2.35).

Remove the grill and the filter from the grill frame. Insert the frame into the box and mount in place with the screws provided through a hole at each corner of the frame. Finally, place the air filter into the frame and replace the grill. Turn the latches a quarter turn to lock the grille in place. Slide a clamp band (provided with return air box) over one end of the return air duct. Place that end over the elliptical flange on the fan coil unit (see Figure 2.36). Move the clamp over the flange and tighten so the clamp holds the return air duct securely to the flange.

Follow the same procedures to attach the return air duct to the return air box (see Figure 2.36).

FIGURE 2.35: RETURN AIR BOX INSTALLATION

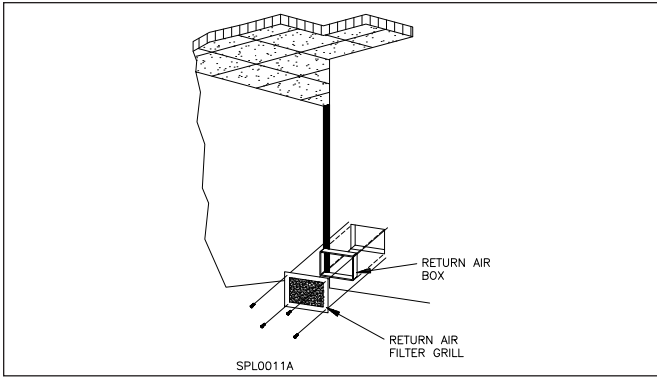
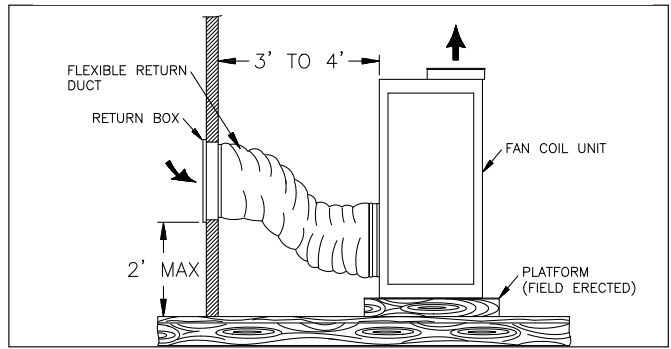

FIGURE 2.36: TYPICAL CLOSET/UTILITY ROOM INSTALLATION



Winter Supply Shut-Off Installation

Simply insert winter supply shut-offs into the room terminator openings (see Figure 2.37). Wrap the return air filter in a plastic bag and reinstall it to block the return air opening. Winter supply shut-offs prevent moisture from collecting in ductwork during winter months. Be sure to remove the plastic bag and all winter supply shut-offs before operating the system.

FIGURE 2.37: WINTER SUPPLY SHUT-OFF

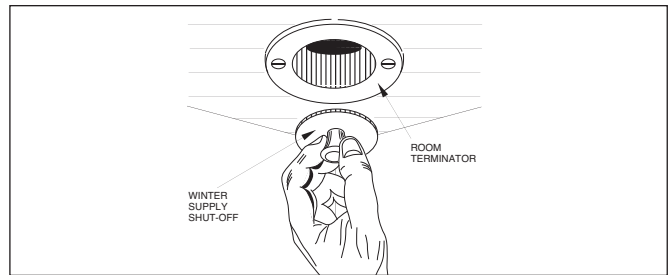

Step 9: B & C Series Unit Retrofits

For retrofitting an ESP-J series unit to an existing ESP-B or C series, some modifications will need to be made to the current system. The necessary changes are below and the extent of the changes is dependent upon the model of the unit. (Refer to Figures 2.38 / 2.39 / 2.40)

ESP-2430 Retrofits

The 7" duct can still be utilized with a transition kit (Part No. BM-6918) available from SpacePak. This kit will reduce the main plenum from 9" to 7" to adapt to the existing 7" duct.

ESP-3642/4860 Retrofits

The existing plenum duct, which is typically 7", will need to be replaced with 8" X 8" duct board or field supplied 9" round duct. The return duct and return grille will also have to be replaced with the proper parts for the replacement

model. The reason for this change is the amount of air supplied by current models is 30% higher than the B & C Series models. The existing 7" duct work will reduce the air flow and cause excessive static pressures resulting in lack of performance and could possibly freeze up the coil which will result in compressor failure due to short cycling.

NOTICE FOR ALL RETROFITS

It may be necessary to add outlets to the system. The number of additional outlets will be dependent upon the external static pressure which should be measured with a manometer. This measurement should be between 1.2-1.3" WC. For more details on this test procedure and location for the test, refer to the System Start Up and Adjustment section in this installation manual.

FIGURE 2.38: STRAIGHT DUCT OR SHOTGUN LAYOUT

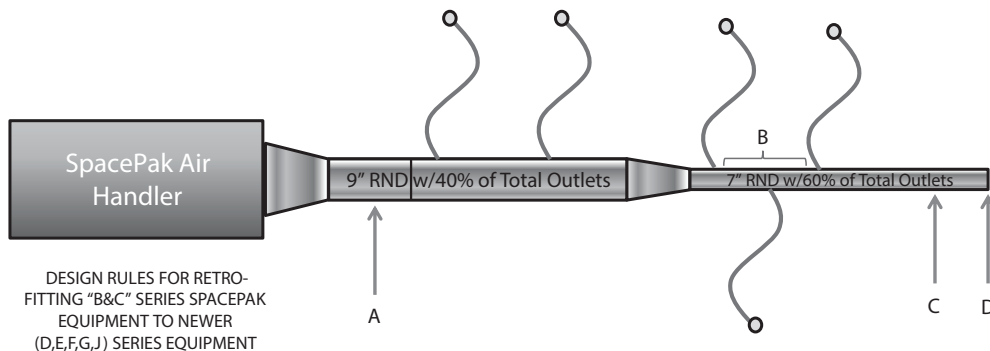

DESIGN RULES FOR RETROFITTING "B&C" SERIES SPACEPAK EQUIPMENT TO NEWER (D,E,F,G,J) SERIES EQUIPMENT

- A: No outlets in the first 18" of straight pipe coming off the Air Handler
- B: Minimum distance between outlets is 6" on center
- C: Minimum distance when placing an outlet from end cap is 12"
- D: NEVER place an outlet in the End Cap

FIGURE 2.39: HORSESHOE LAYOUT

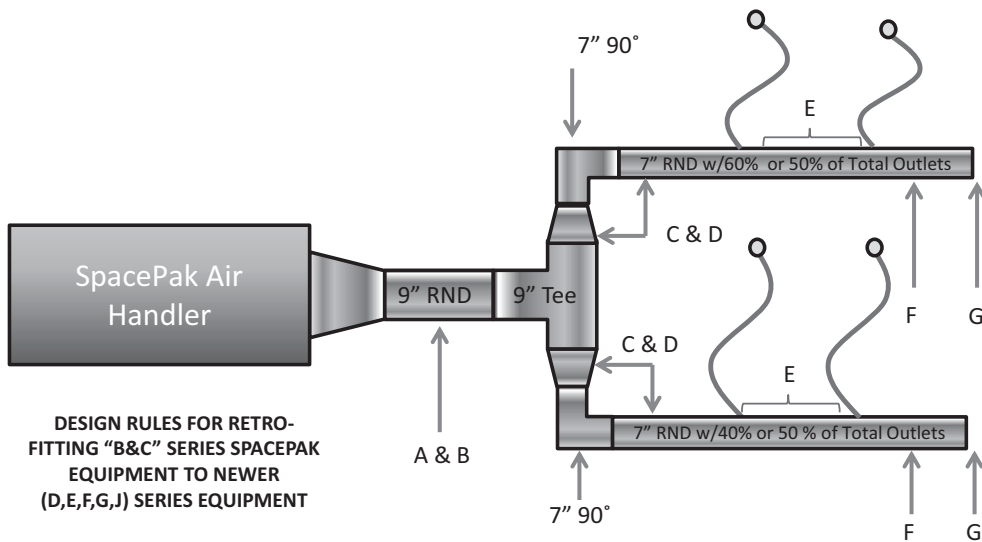

- A: Minimum distance from the air handler outlet to first tee or elbow is 18"
- B: No outlets in the first 18" of straight pipe off of the air handler
- C: Minimum distance of straight pipe after any tee or elbow is 18"
- D: Minimum distance when placing outlet after any tee or elbow is 18"
- E: Minimum distance between outlets is 6" on center
- F: Minimum distance when placing an outlet from the end cap is 12"
- G: Never place an outlet in the end cap

FIGURE 2.40: SIDE BRANCH

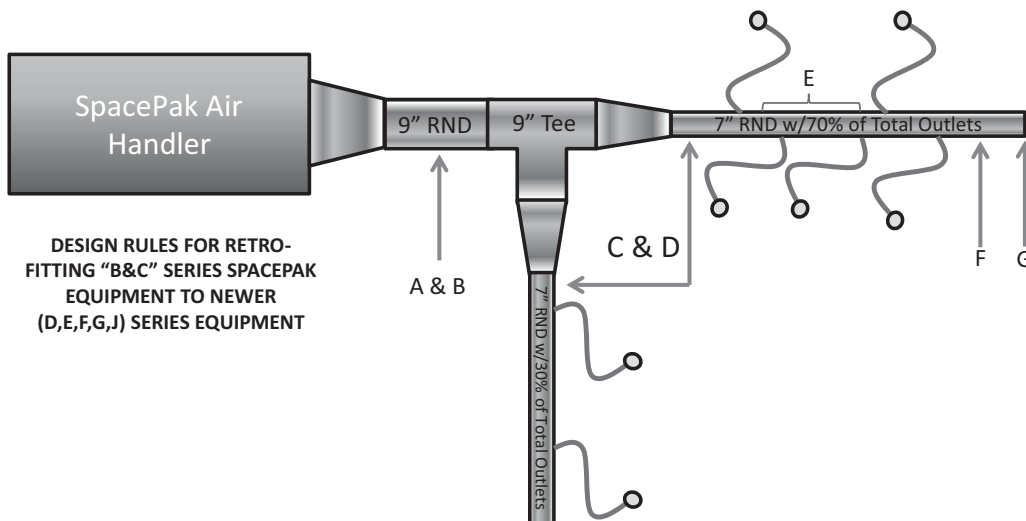

- A: Minimum distance from the air handler outlet to first tee or elbow is 18"
- B: No outlets in the first 18" of straight pipe off of the air handler
- C: Minimum distance of straight pipe after any tee or elbow is 18"
- D: Minimum distance when placing outlet after any tee or elbow is 18"
- E: Minimum distance between outlets is 6" on center
- F: Minimum distance when placing an outlet from the end cap is 12"
- G: Never place an outlet in the end cap

Integral Air Handler Control

The SpacePak ESP and WCSP air handlers now feature a sophisticated control platform that has the ability to control fan speed by measuring static pressure and calculating airflow (CFM), as well as heat exchanger coil temperature.

The fan control logic can be configured to maintain a constant static pressure, or constant fan speed, with individual settings that can be assigned to each of five different operating inputs; Cooling Y1, Cooling Y2, Heating W1, Heating W2, and G fan only. Each set point is adjusted separately through the onscreen interface, which is an integral component of the control board.

In each mode, the fan will gradually increase to the specific set point in order to minimize perceived airflow and duct noise. In the Cooling and Heating modes, the fan will not ramp up to the desired set point until the coil reaches the appropriate temperature. Both heating and cooling fan start set points can be adjusted through the onscreen menu following the menu tree located in this section.

The screen will also display the delivered airflow, in Cubic Feet per Minute, delivered by the air handler. CFM calculation is an approximation based upon laboratory test conditions, and may be affected by certain system construction features such as temperature and elevation. The primary setup criteria for all Small Duct High Velocity systems should always be Duct Static Pressure. CFM and static pressure displayed on screen should be used as REFERENCE ONLY.

All delivered airflow and static pressure, for each application, should be verified upon installation with calibrated equipment to ensure proper system operation and for troubleshooting purposes. For ESP models; The control also manages output signals to the outdoor condenser or heat pump, whether single or dual stage, as well as indoor accessories such as an ERV/HRV, Humidifier, Electric Heater or Auxiliary Hydronic Heating Coil.

For WCSP models; The control also manages output signals to the Geo or Air to Water Heat Pump, as well as indoor accessories such as an ERV/HRV, Humidifier, Electric Heater, Auxiliary Hydronic Heating Coil, or SSIC Hydronic System Interface Controller.

Refer to Section 3 for more detailed description and start-up instruction as well as the appropriate wiring diagrams located in section 2 step 7 of this manual.

SECTION 3: START-UP & COMMISSIONING

Controls Overview/Features/Setpoints

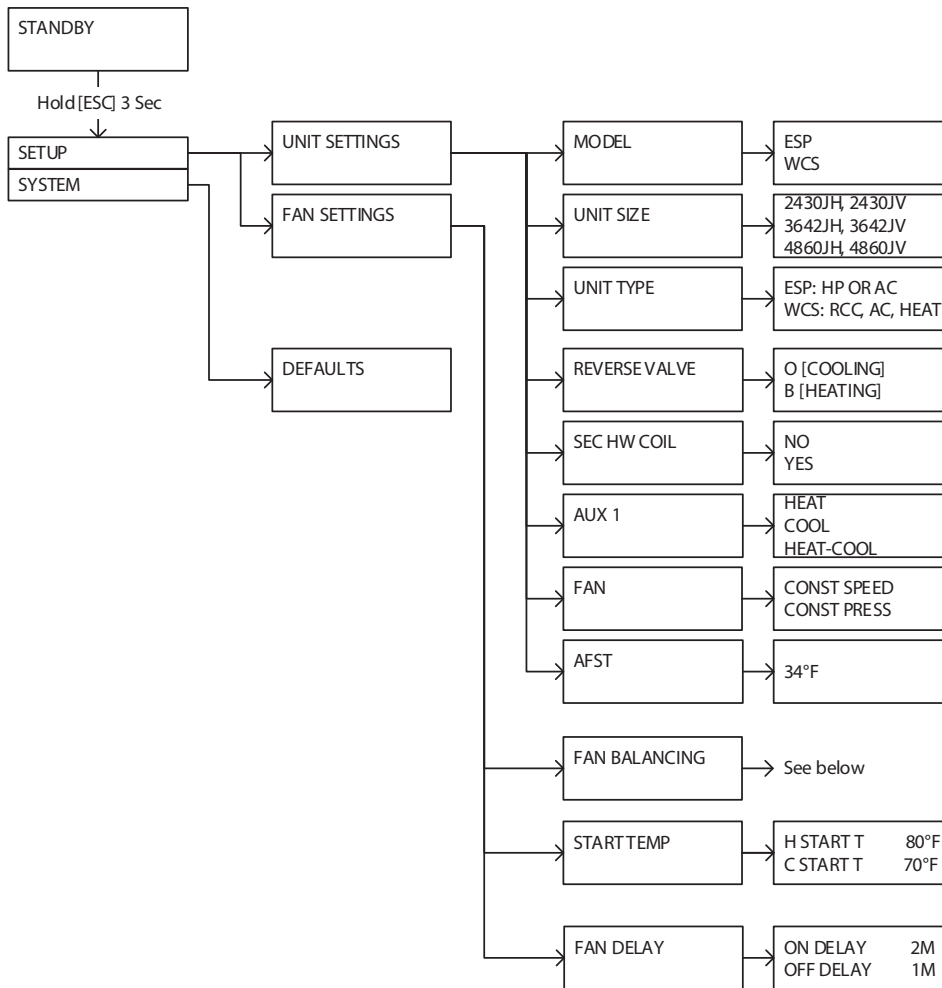

FAN BALANCING – CONSTANT SPEED

Y1:	SPEED%
Y2:	SPEED%
Y12:	SPEED%
W1:	SPEED%
W2:	SPEED%
W12:	SPEED%
G:	SPEED%
HUM:	SPEED%
ERV:	SPEED%
DFS:	SPEED%

➤

Y1%	PRESS	CFM
50	0.4	350
Y2%	PRESS	CFM
50	0.4	350
Y12%	PRESS	CFM
50	0.4	350
W1%	PRESS	CFM
50	0.4	350
W2%	PRESS	CFM
50	0.4	350
W12%	PRESS	CFM
50	0.4	350
G%	PRESS	CFM
50	0.4	350
HUM%	PRESS	CFM
50	0.4	350
ERV%	PRESS	CFM
50	0.4	350
DFS%	PRESS	CFM
50	0.4	350

FAN BALANCING – CONSTANT PRESSURE

Y1:	ST PRESS
Y2:	ST PRESS
Y12:	ST PRESS
W1:	ST PRESS
W2:	ST PRESS
W12:	ST PRESS
G:	ST PRESS
HUM:	ST PRESS
ERV:	ST PRESS
DFS:	ST PRESS



➤

Y1 SP	PRESS	CFM
1.2	0.51	350
Y2 SP	PRESS	CFM
1.2	0.51	350
Y12 SP	PRESS	CFM
1.2	0.51	350
W1 SP	PRESS	CFM
1.2	0.51	350
W2 SP	PRESS	CFM
1.2	0.51	350
W12 SP	PRESS	CFM
1.2	0.51	350
G SP	PRESS	CFM
1.2	0.51	350
HUM SP	PRESS	CFM
1.2	0.51	350
ERV SP	PRESS	CFM
1.2	0.51	350
DFS SP	PRESS	CFM
1.2	0.51	350

Menu navigation is accomplished by using the buttons located to the right side of the J+ control board.

ESC  **Escape key**, used to exit menus and to undo changes.

SEL  **Selection key**, used to select features and to save changes.

UP  and DOWN  **Directional keys**, used to navigate menus and to change parameters.

Press the ESC key for 3 seconds to enter the control menu system.

SETUP	UNIT SETTINGS
	FAN SETTINGS
	TIMERS
SYSTEM	DEFAULTS

SETUP MENU

The SETUP menu has 3 submenus: UNIT SETTINGS, FAN SETTINGS, and TIMERS.

1. UNIT SETTINGS

The UNIT SETTINGS menu consists of 8 submenus: MODEL, UNIT SIZE, UNIT TYPE, Reversing valve [REVERSE VALVE] settings, Secondary Hot Water Coil [SEC HW COIL], Auxiliary Relay 1[AUX 1], [FAN] CONSTANT SPEED or CONSTANT PRESSURE driven operation, and anti-frost temperature setting [AFST TEMP].

UNIT SETTINGS	MODEL
	UNIT SIZE
	UNIT TYPE
	REVERSE VALVE
	SEC HW COIL
	AUX 1
	FAN
	AFST TEMP

1.1 MODEL: This menu will allow you to select the model of the unit: ESP or WCSP.

1.2 UNIT SIZE: There are 6 unit sizes options: 2430H/V, 3642H/V, and 4860H/V.

1.3 UNIT TYPE: An ESP model can be configured as refrigerant heat pump by selecting [HP], or as cooling only mode available [AC] unit. A WCSP mode can be configured as a Reverse cycle chiller [RCC], or as a cooling only [AC] unit or as a heating only mode [HEAT] unit.

Note: These selections should only be changed by a qualified installer and should be verified for the installation.

Note: The unit model, and size will be configured specific to the purchased unit from the factory.

UNIT TYPE	HP	For ESP units:
	AC	

UNIT TYPE	RCC	For WCSP units:
	AC	
	HEAT	

1.4 REVERSE VALVE: The Reversing Valve [REVERSE VALVE] can be set to O [energized in cooling] or B [energized in heating]

REVERSE VALVE	O
	B

1.5 SEC HW COIL: The Secondary Hot Water Coil menu [SEC HW COIL] allows you to add a secondary heating water coil as an optional item.

SEC HW COIL	NO
	YES

1.6 AUX 1: The Auxiliary 1 Relay [AUX 1] can be set to close its contacts only during a heating call, only during a cooling call only or on both heating and cooling calls.

AUX 1	HEAT
	COOL
	HEAT-COOL

1.7 Fan Speed: The fan can be run at either a constant speed or a constant static pressure.

FAN	CONST SPEED
	CONST PRESS

When Constant Speed is selected a different speed % can be selected for each input. (Y1, Y2, W1, W2, or G). The fan will run at the set speed % for the active input. This setting can be from 5% - 100%

When Constant Pressure is selected a different static pressure setpoint can be selected for each input. (Y1, Y2, W1, W2 or G). The fan will vary its speed to maintain the static pressure target of the active input.

See section 2, FAN SETTINGS, for information on setting the speed % or static pressure setpoints.

1.8 Anti-Frost protection temperature setting: The Anti-Frost Protection Temperature setting [AFST TEMP] controls the integrated Anti-frost feature. The default setting is 34°F, and is adjustable up to 50°F. The temperature of the primary coil is constantly monitored. If the coil temperature drops below the Anti-Frost Protection Temperature setting the Anti-frost feature will be enabled, the fan will continue run at the called for speed, but all HVAC outputs will be disabled. The feature will be disabled once the primary coil temperature rises 10°F above this setting.

AFST TEMP	34°F
-----------	------

2. FAN SETTINGS

The FAN SETTINGS menu consists of 3 sub menus: FAN BALANCING, START TEMP, and FAN DELAY

FAN SETTINGS	FAN BALANCING
	START TEMP
	FAN DELAY

2.1 FAN BALANCING: The FAN MODE setting will determine the appearance of the FAN BALANCING menu. If CONSTANT SPEED has been selected, the SPEED% setting can be adjusted for each input.

FAN:CONST SPEED%	Y1:	SPEED%	Y1%	PRESS	CFM
			50	0.4	350
	Y2:	SPEED%	Y2%	PRESS	CFM
			50	0.4	350
	Y12:	SPEED%	Y12%	PRESS	CFM
			50	0.4	350
	W1:	SPEED%	W1%	PRESS	CFM
			50	0.4	350
	W2:	SPEED%	W2%	PRESS	CFM
			50	0.4	350
	W12:	SPEED%	W12%	PRESS	CFM
			50	0.4	350
	G:	SPEED%	G%	PRESS	CFM
			50	0.4	350
	HUM:	SPEED%	HUM%	PRESS	CFM
			50	0.4	350
	ERV:	SPEED%	ERV%	PRESS	CFM
			50	0.4	350
	DFS:	SPEED%	DFS%	PRESS	CFM
			50	0.4	350

For example: If FAN: CONSTANT SPEED has been selected, then selecting “Y1: SPEED%” will display:

Y1%	PRESS	CFM
50	0.4	350

The default speed value is 50%. Line 1 displays the units, and line 2 shows the real time value of the parameters. Selecting Y1% will set the cursor at line 2 indicating real time adjustment is active. UP and Down clicks will change Y1% increasing the fan speed value up to 100% or decreasing it down to 5%. The Pressure and CFM values are constantly being updated to provide feedback to the fan speed changes. You must hit SEL to save the desired setpoint.

If CONSTANT PRESSURE has been selected the static pressure setpoint can be adjusted for each input.

FAN:CONST PRESS	Y1:	ST PRESS	Y1 SP	PRES	CFM
			1.2	0.39	350
	Y2:	ST PRESS	Y2 SP	PRES	CFM
			1.2	0.39	350
	Y12:	ST PRESS	Y12 SP	PRES	CFM
			1.2	0.39	350
	W1:	ST PRESS	W1 SP	PRES	CFM
			1.2	0.39	350
	W2:	ST PRESS	W2 SP	PRES	CFM
			1.2	0.39	350
	W12:	ST PRESS	W12 SP	PRES	CFM
			1.2	0.39	350
	G:	ST PRESS	G SP	PRES	CFM
			1.2	0.39	350
	HUM:	ST PRESS	HUM SP	PRES	CFM
			1.2	0.39	350
	ERV:	ST PRESS	ERV SP	PRES	CFM
			1.2	0.39	350
	DFS:	ST PRESS	HRV SP	PRES	CFM
			1.2	0.39	350

For example: If FAN: CONSTANT PRESSURE has been selected, selecting “Y1: ST PRESS” will display:

Y1 SP	PRES	CFM
1.2	0.39	350

The default pressure setpoint 1.2” WC. Line 1 shows the units. Line 2 shows the real time value of the parameters. Selecting Y1 will set the cursor to line 2, indicating real time adjustment is active. UP and Down clicks will change the static pressure setpoint, either increasing the value to up to 2.5” WC or decreasing it down to 0.5” WC. The fan speed will vary to maintain the selected static pressure setpoint. You must hit SEL to save the desired set-point.

2.2 FAN START TEMP: The temperature of the heating/cooling coils is constantly being monitored. When a call for heating or cooling is received the fan will not start until the coil is at the appropriate temperature. This assures the coil is at the correct temperature to avoid initially delivering warm air for a cooling call or cool air for a heating call. The Fan Start Temperature [START TEMP] menu allows the target coil temperature to be adjusted. The default target temperature for heating is 80°F and the default target temperature for cooling is 70°F.

START TEMP	H START T	80°F
	C START T	70°F

2.3 FAN DELAY: The FAN DELAY menu contains 2 settings: ON DELAY and OFF DELAY.

FAN DELAY	ON DELAY	2 m
	OFF DELAY	1 m

The FAN ON DELAY is only used if a coil sensor is in fault. If the J+ board recognizes a coil temperature sensor is not installed or has faulted the FAN ON DELAY will be used to delay the fan from coming on to allow the coil time to get to the target temperature.

The FAN OFF DELAY is always used to allow the fan to optionally run for a time after a demand has been satisfied allowing time to offload the coil of any excess heat that may still be present.

SYSTEM MENU

The System menu consists of two items; Defaults and Cal pressure.

SYSTEM	DEFAULTS
--------	----------

The DEFAULTS menu allows all settings to be returned to factory default values indicated in Defaults Section. UNIT MODEL and UNIT SIZE are not changed when loading factory defaults.

RUN SCREEN

There are 5 run screens that show the current status of the unit. Pressing the UP or DOWN buttons will cycle through the 5 screens.

Run Screen #1.

Line 1 shows the status of the unit: STANDBY, HEATING, COOLING, or FAN.

Line 2 shows the HVAC inputs currently present: O/B, Y1, Y2, W1, W2, G, HUMIDIFIER [HUM] and ERV. Line 2 will also display faults, warnings, and errors. Fault, warnings, and configuration errors are found in the FAULT section of this manual at the last 3 pages of this manual.

Examples

S T A N D B Y	Line1 Line 2
---------------	-----------------

Line 1: Heating call
Line 2: B, Y1 and Y2 HVAC inputs are energized and the humidifier is running.

H E A T I N G B Y 1 Y 2	HUM
----------------------------	-----

Line 1: Cooling call
Line 2: O and Y1 HVAC inputs are energized.

C O O L I N G O Y 1	
------------------------	--

Line 1: Heating call
Line 2: W1 HVAC input is energized

H E A T I N G W 1	
----------------------	--

Line 1: Fan is running
Line 2: G HVAC input is energized

F A N G	
------------	--

Line 1: FAN, and Humidifier are running
Line 2: Humidifier [HSTAT] HVAC input is energized

F A N H S T A T	HUM
--------------------	-----

Line 1: FAN and Humidifier are running
Line 2: G, and Humidifier [HSTAT] HVAC inputs are energized

F A N G H S T A T	HUM
----------------------	-----

Line 1: FAN, and ERV are running
Line 2: ERV input is energized

F A N E R V	
----------------	--

Run Screen #2.

Line 1 displays the measured static pressure in Inches of water column ["WC]
Line 2 show the Airflow in cubic feet per minute [CFM]

P R E S S U R E 1 . 2 0 " W C A I R F L O W 9 4 0 C F M
--

Run Screen #3, and #4.

Run screen #3 and #4 display coil temperature readings and the leaving air temperature. If a temperature sensor is not installed "NONE" will be displayed, if a temperate sensor is faulted in a shorted or open condition, SHORTED or OPEN will be displayed.

Examples:

Run Screen #3.

C O I L 1	7 4 ° F
C O I L 2	8 0 ° F

Note: If the Secondary Hot Water Coil [SEC HW COIL] is disabled, line 2 will be blank.

```

C O I L   1           O P E N
C O I L   2           N O N E

```

Run Screen #4.

```

L A T           7 4 ° F
F A N   S P E E D %           1 0 0

```

Run Screen #5.

Line 1 shows the Model and Size.
 Line 2 shows the Unit type: Reverse Cycle Chiller, Heat Pump, Cooling or Heating mode only, as well as the Reversing valve setting, and the secondary heating water coil if installed.

Examples

Unit Configuration: ESP model, size 3642J, horizontal [H] unit, configured as heat pump with its reversing valve set to energize in cooling and a secondary hot water coil installed

```

M O D E L   E S P   3 6 4 2 JH
H P   O   H W C

```

Unit Configuration: ESP model, size 2430J, vertical [V] unit, configured as a heat pump with its reversing valve set to energize in heating and a secondary hot water coil installed

```

M O D E L   E S P   2 4 3 0   JV
H P   B   H W C

```

Unit Configuration: WCS model, size 3642J horizontal [H] unit, configured as a reverse cycle chiller with its reversing valve set to energize in heating

```

M O D E L   W C S   3 6 4 2 JH
R C C   O

```

FAULTS:

Ifaults are flashed on the 2nd line on all run screens during all operations.

Float switch fault: The condensate float switch is open.

```

S T A N B Y
F L O A T   S W           F A U L T

```

Anti-frost fault: The primary coil has dropped below the Anti-frost temperature setpoint.

```

C O O L I N G
A N T I F R O S T           F A U L T

```

Pressure transducer fault: The pressure transducer is has failed.

```

C O O L I N G
T R A N S D U C E R   F A U L T

```

Low pressure fault: The pressure transducer is reading below 0.1" when the fan is running.

```

C O O L
L O W   P R E S S   F A U L T

```

WARNINGS:

There are 10 warnings. The unit will continue to run during these warnings:

1. OPEN COIL 1 – The coil 1 temperature sensor is open
2. SHORTED COIL 1 – The coil 1 temperature sensor is shorted.
3. OPEN COIL 2 – The coil 2 temperature sensor is open
4. SHORTED COIL 2 – The coil 2 temperature sensor is shorted.
5. OPEN LAT – The leaving air temperature sensor is open
6. SHORTED LAT – The leaving air temperature sensor is shorted.
7. COIL1 NOT FOUND – The coil 1 temperature sensor not found at power up.
8. COIL2 NOT FOUND – The coil 2 temperature sensor is expected, but not found at power up.
9. HWC DISABLE – The coil 2 sensor is recognized although the secondary coil is [SEC HW COIL] is disabled
10. DEFROST – The heat pump has entered defrost mode.

Examples

Run Screen #1 displaying warnings.

Line 1 shows the status of the unit: STANDBY, HEATING, COOLING, or FAN.

Line 2 shows faults, warnings, and errors.

```
S T A N D B Y
O P E N           C O I L 1
```

```
C O O L I N G
S H O R T E D     C O I L 1
```

```
H E A T I N G
D E F R O S T
```

```
S T A N D B Y
C O I L 1       N O T F O U N D
```

```
H E A T I N G
C O I L 2       N O T F O U N D
```

```
H E A T I N G
H W C           D I S A B L E
```

ERRORS:

Configuration - Wiring Errors.

The J+ Control is able to recognize wiring and configuration errors. If conflicting inputs are received, the control will always prioritize heating over cooling an error message will be displayed, but the unit will continue to operate.

```
E R R O R 2           O B + W
H W C                 D I S A B L E
```

Based on the unit configuration the following errors can be recognized.

Unit Configuration: HP/ RCC

RV = O [REVERSE VALVE ON COOLING]

For Heating Mode: Expected inputs: Y's, Y's+W's.

For Cooling Mode: Expected inputs: Y's+OB.

RV = B [REVERSE VALVE ON HEATING]

For Heating Mode: Expected inputs: Y's+OB, Y's+OB+W's

For Cooling Mode: Expected inputs: Y's.

Detected inputs; W's+OB or OB

ERRORS:

Error 1: Unexpected OB, Configuration error.

Wiring error.

Error 2: Unexpected W's+OB, Configuration error.

Wiring error.

Unit Configuration: COOL ONLY FOR BOTH MODELS

Expected inputs: Y's or W's.

Detected input: OB

ERRORS:

Error 1: Unexpected OB, Configuration error. Wiring error.

Error 2: Unexpected W's + OB, Configuration error. Wiring error.

Error 3: Unexpected Y's + OB, Configuration error. Wiring error.

Error 4: Unexpected Y's + W's, Configuration error. Wiring error.

Unit Configuration: HEAT ONLY FOR WCS ONLY

Expected inputs: W's.

Detected inputs; Y's, Y's+OB, or OB

ERRORS:

Error 1: Unexpected OB, Configuration error. Wiring error.

Error 3: Unexpected Y'S + OB, Configuration error. Wiring error

Error 5: Unexpected Y'S, Configuration error.

Wiring error.

ADDITIONAL SUPPLEMENTARY FEATURES OF THE J+ CONTROL

The J+ control has 3 inputs that can be used to interface to additional equipment. These inputs are enabled when 24VAC is applied.

Energy Recovery

An Energy Recovery Ventilator can use the [ERV] input to have the J+ unit run the fan. If the fan is already running, the fan will continue to run at the speed set by the active thermostat inputs. If the fan is not running the fan will run at the [ERV] fan setting.

Humidifier

The Humidifier [HUM] input can be used to have the J+ control enable an external humidifier by using the [HUMDFR] relay output. The [HUMDFR] relay output is a dry set of contacts. If the fan is running already the fan will continue to run at the speed set by the active thermostat inputs. If the fan is not running the fan will run at the humidifier [HUM] fan setting.

HP Defrost

The Defrost input [DFS] input can be used by a heat pump to notify the J+ control that it has entered defrost mode. In this mode the W2 relay output will be enabled, and if the fan is running already the fan will continue to run at the speed set by the active thermostat inputs. If the fan is not running the fan will run at the defrost [DFS] fan settings.

Aux2 & Aux3

In a unit that is commissioned for ESP. The Aux2 terminal will always be energized during any cooling call and the Aux3 terminal will always be energized in a heating call.. In a unit that is commissioned for WCSP. The Aux2 and 3 terminals are designed to work with the Spacepak Air to Water Heat pump family of products. Aux2 will be wired to the “remote on/off” terminals located in the air to water heat pump electrical compartment and Aux3 will be wired to the “Heat/Cool” terminals of the air to water heat pump. Refer to your specific air to water heat pump for the exact terminal numbers, wiring locations and follow the recommended piping practices detailed in the manual for the specific air to water heat pump.

DEFAULTS

ITEM DESCRIPTION	DEFAULT	MAX	MIN
UNIT MODEL*	PER UNIT PURCHASED		
UNIT SIZE*	PER UNIT PURCHASED		
UNIT TYPE	HP		
REVERSING VALVE	O		
SEC HW COIL	NO		
AUX 1	HEAT		
FAN	CONSTANT PRESSURE		
ANTI FROST TEMPERATURE	34	50°F	34°F
SPEED Y1	50%	100%	5%
SPEED Y2	50%	100%	5%
SPEED Y12	50%	100%	5%
SPEED W1	50%	100%	5%
SPEED W2	50%	100%	5%
SPEED W12	50%	100%	5%
SPEED G	50%	100%	5%
SPEED HUMIDIFIER	50%	100%	5%
SPEED ERV	50%	100%	5%
SPEED DEFROST [DFS]	30%	100%	5%
STATIC PRESSURE Y1	1.2 "WC	2.5 "WC	0.5 "WC
STATIC PRESSURE Y2	1.2 "WC	2.5 "WC	0.5 "WC
STATIC PRESSURE Y12	1.2 "WC	2.5 "WC	0.5 "WC
STATIC PRESSURE W1	1.2 "WC	2.5 "WC	0.5 "WC
STATIC PRESSURE W2	1.2 "WC	2.5 "WC	0.5 "WC
STATIC PRESSURE W12	1.2 "WC	2.5 "WC	0.5 "WC
STATIC PRESSURE G	1.2 "WC	2.5 "WC	0.5 "WC
STATIC PRESSURE HUMIDIFIER	1.2 "WC	2.5 "WC	0.5 "WC
STATIC PRESSURE ERV	1.2 "WC	2.5 "WC	0.5 "WC
STATIC PRESSURE DEFROST [DFS]	0.7 "WC	2.5 "WC	0.5 "WC
HEATING START TEMPERATURE	80	120°F	60°F
COOLING START TEMPERATURE	70	80°F	50°F
FAN ON DELAY	2 MINUTES	5 MIN	1 MIN
FAN OFF DELAY	1 MINUTES	5 MIN	0 MIN

*UNIT MODEL and UNIT SIZE are not reset when loading Factory Defaults

SYSTEM COMMISSIONING

1. Check that system static pressure is within acceptable limits (minimum 1.2" WC - ,maximum 1.3" WC). You can use a U-tube manometer to check the external static pressure on the duct system.
 1. Puncture a 1/4" diameter hole in the plenum duct at least 18" from the fan coil unit.
 2. Insert the high-side manometer tube into the hole so that the end is approximately flush with the inside wall of the plenum, and perpendicular to the direction of airflow.
 3. System static pressure should be between 1.2" and 1.3" WC.
 - a. If the pressure is higher than 1.2" provide additional supply runs to increase airflow or lower the fan speed by turning the fan speed adjustment for the current mode of operation counter-clockwise to reduce the static pressure.
 - b. If the pressure is lower than 1.2", look for leaks in the supply plenum, restrictions in the return system (including clogged filters) If more than the recommended number of supply runs are installed, you may install flow restrictors (orifices) in these runs. If the number of runs is appropriate for the load, increase the static pressure by turning fan speed adjustment for the current mode of operation clockwise to increase the static pressure.
2. Check that blower motor amp draw compares with fan coil unit rating plate. Amp draw shown on plate is the FLA of motor (not the actual running amps) and will vary with the pressure and voltage.
3. Place the thermostat cooling indicator in COOL position, which will start the outdoor unit. Let the system run at least 30 minutes to stabilize operating conditions.
4. For outdoor unit start-up, follow manufacturer's instructions.

5. Check that temperature drop across evaporator coil in the indoor unit is between 20°F to 28°F.

NOTICE: Do not introduce refrigerant liquid to system through suction port. Liquid in the suction line may damage the compressor.

NOTICE: Before adding refrigerant to system verify Item #1 has been performed.

6. Verify that system refrigerant is correct by measuring subcooling at liquid service port. Subcooling should be in accordance with outdoor unit manufacturers recommendations.
7. Check the super heat leaving the evaporator coil against the corresponding suction pressure from the schrader fitting at the fan coil unit. Superheat value should be between 9°F and 12°F.
8. If a sight glass has been installed on the liquid line at the air handler check for the presence of flashing. If flashing is occurring, check and adjust subcooling by adding refrigerant.

CHARGING COOLING ONLY SYSTEMS

After start-up, allow the system to operate for approximately 30 minutes in order to establish stable operating conditions. Check that the temperature drop across the evaporator coil is 20°F to 30°F. Do not attempt to adjust the charge at ambient temperatures below 65°F.

Verify and adjust refrigerant charge based upon outdoor unit manufacturer's published recommendations.

▲ CAUTION Releasing refrigerant gas into the atmosphere is a criminal offense.

FACTORS AFFECTING THE BALANCE OF THE SYSTEM

A. Room Terminators (Outlets): Based on the equipment selected, determine the recommended number of fully open outlets from Figure 3.1.

1. The minimum or recommended number of outlets means fully open outlets. Any outlet having an orifice would be only a percentage of an outlet.

FIGURE 3.1

NOMINAL TONNAGE	MINIMUM RECOMMENDED NUMBER OF FULLY OPEN OUTLETS		
	MODEL	A	B
2	ESP-2430J-V	12	14
2-1/2	ESP-2430J-V	15	18
3	ESP-3642J-V	18	21
3-1/2	ESP-3642J-V	21	25
4	ESP-4860J-V	26	28
5	ESP-4860J-V	30	35

2. For systems with average supply tubing lengths of 15 feet or less, use column A. For systems with supply tubing lengths greater than 15 feet, use column B.

NOTICE: The number of outlets and average length of the supply tubing has a significant effect on the overall system performance. It is highly recommended that the adjustment factors outlined in the SpacePak Application Manual are accounted for prior to any installation.

B. Orifice Combinations: Should orifices be required to balance the system (installed at plenum take-off), refer to the combinations listed in Figure 3.2.

FIGURE 3.2

DESIRED NUMBER OF TERMINALS*	TERMINAL - ORIFICE COMBINATION
.5	(1) .5
.65	(1) .35
.85	(1) .15
1.00	(1)
1.15	(1) .5 + (1) .35
1.30	(2) .35
1.50	(1) .35 + (1) .15 or (1) + (1) .5 or (3) .5
1.65	(1) + (1) .35 or (2) .5 + (1) .35
1.70	(2) .15
1.80	(2) .35 + (1) .5
1.85	(1) + (1) .15
1.95	(3) .35
2.00	(2)

*For a room with more than two (2) terminals, combinations of the above may be used to achieve the desired fractional number.

C. Supply Tubing Length: An outlet with a supply tubing length of 15 feet is considered one, fully opened outlet. For other lengths refer to Figure 3.3 for adjustment factors.

FIGURE 3.3

2" SUPPLY TUBING LENGTH ADJUSTMENT FACTOR CHART								
RUN	6'	8'	10'	12'	15'	20'	25'	30'
FACTOR	1.18	1.14	1.11	1.06	1.0	.9	.8	.66

SECTION 4: MAINTENANCE

The SpacePak system has been designed to provide years of trouble-free performance in normal installations. Examination by the homeowner at the beginning of each cooling season, and in mid-season should assure continued, good performance. In addition, the system should be examined by a qualified service professional at least once every year.

BEFORE EACH COOLING SEASON

1. Check and clean air filter. The air filter is permanent type. Remove and clean thoroughly with soap solution and water.

▲ WARNING Turn off electrical power supply before servicing. Contact with live electric components can cause shock or death.

2. Check fan coil unit. Turn off unit power disconnect switch and remove service access panels.
 - a. Inspect evaporator coil and blower wheel for build-up of dust and dirt. Clean with solvent and/ or water as necessary.
 - b. Replace service access panels and turn on unit power disconnect switch.
3. Check that unit condensate drain is clear and free running, and plug is in cleanout.

4. For outdoor condensing unit, follow manufacturer's maintenance instructions.
5. Follow "System Start-Up & Adjustments" procedures in Section 3 of this manual.

IF SYSTEM FAILS TO OPERATE

1. Check that thermostat switch is set for proper mode of operation and is set below room temperature.
2. Check that outdoor unit is operating.
 - a. Confirm that compressor and fan are operating properly.
 - b. Confirm voltages to outdoor unit.

IF FAN AND COMPRESSOR AT OUTDOOR UNIT ARE NOT RUNNING

1. Check Fault Indicator. See Flash Codes, page 19. Float switch fault will stop fan and compressor.
2. Check for tripped circuit breaker or blown fuse at either the main fuse box or at unit disconnect box on or near the condensing unit. Replace blown fuse with same size and type.
3. Review Troubleshooting Guide beginning on page 34 of this manual.

TROUBLESHOOTING GUIDE

CONDITION: ESP-J & CONDENSING UNITS RUN, BUT COOLING INSUFFICIENT

POSSIBLE CAUSE	VERIFICATION	SOLUTION
Low Suction Pressure	Check blower motor as described on page 38 in this manual.	If defective, replace motor.
	Check that filter in return air box is clean.	Clean air filter.
	Check system refrigerant charge.	Charge to proper subcooling according to manufacturer's instructions.
	Check for dirty evaporator coil.	Clean evaporator coil.
High Suction Pressure	Check for air bubbles in system refrigerant.	Charge to proper subcooling according to condensing unit manufacturer's instructions. Install sight glass near indoor unit and monitor.
	Check calculated heat gain to be sure that equipment is sized properly.	Take necessary action.
	Check for obstructions near condensing unit which could cause recirculation of air.	Remove obstructions.
Low Head Pressure	Check system refrigerant charge.	Charge to proper subcooling according to condensing unit manufacturer's instructions.
	Check calculated heat gain to be sure that equipment is sized properly.	Take necessary action.
High Head Pressure	Check condenser fan motor according to condensing unit manufacturer's instructions.	If defective, replace fan motor.
	Check for dirty condensing unit coil.	Clean condensing unit coil.
	Check system refrigerant charge.	Charge to proper subcooling according to condensing unit manufacturer's instructions.
	Check for dirty evaporator coil.	Clean evaporator coil.
	Check for obstructions near condensing unit which could cause recirculation of air.	Remove obstructions.
	Check for restricted liquid lines.	Remove restrictions and kinks from lines.
Distribution System Air Leaks	Check all joints in air distribution system.	Make sure all joints are air tight. Verify static pressure as described on page 38 in this manual.

CONDITION: ESP-J UNIT & CONDENSING UNIT WILL NOT START

POSSIBLE CAUSE	VERIFICATION	SOLUTION
Thermostat Not Level	Check level of thermostat	If necessary, level thermostat.
Defective Thermostat	With volt meter, check resistance of thermostat contacts.	If resistance, thermostat is O.K. If no resistance, replace thermostat.
Loose Low Voltage Wiring	Check all wiring connections for tightness.	Tighten all loose connections.
Defective Low Voltage Transformer	Check transformer as described on page 38 in this manual.	If defective, replace transformer.
Inadequate Electrical Service	Check electrical service against minimum requirements.	Replace electrical service with adequately sized service.

CONDITION: ESP-J UNIT WILL NOT START, BUT CONDENSING UNIT RUNS

POSSIBLE CAUSE	VERIFICATION	SOLUTION
Speed Control Adjustments Set to Zero	Remove electrical box cover to access the speed control.	Access speed settings in control menus (refer to start-up section) and ensure blower speeds are not set to "0".
Shorted Or Broken Wiring	Check wiring.	If necessary, repair or replace wiring.
Loose Low or High Voltage Wiring	Check all wiring connections for tightness.	Tighten all loose connections.
Defective Blower Motor	Check motor as described on page 38 in this manual.	If defective, replace motor.

CONDITION: ESP-J UNIT RUNS, BUT CONDENSING UNIT WILL NOT START

POSSIBLE CAUSE	VERIFICATION	SOLUTION
Defective Thermostat	With volt meter, check resistance of thermostat contacts.	If resistance, thermostat is O.K. If no resistance, replace thermostat.
Loose Low Or High Voltage Wiring	Check all wiring connections for tightness.	Tighten all loose connections.
Shorted Or Broken Wiring	Check wiring.	If necessary, repair or replace wiring.
Condensing Unit	Check according to manufacturer's instructions.	Repair or replace as directed by manufacturer.

CONDITION: ESP-J UNIT WILL NOT START, BUT CONDENSING UNIT CYCLES

POSSIBLE CAUSE	VERIFICATION	SOLUTION
Incorrect Low Voltage Connections	Check low voltage connections against wiring diagram.	Correct low voltage connections.
Loose Low Voltage Connections	Check all wiring connections for tightness.	Tighten all loose connections.
Defective Blower Motor	Check motor as described on page 38 in this manual.	If defective, replace motor.

CONDITION: ESP-J UNIT CYCLES, BUT CONDENSING UNIT RUNS

POSSIBLE CAUSE	VERIFICATION	SOLUTION
Blower Motor	Check motor as described on page 38 in this manual.	If defective, replace motor.
	Check motor amps and compare to nameplate ratings.	If excessive, motor may be overloaded. Check supply duct for breaks or leaks.

CONDITION: ESP-J UNIT RUNS, BUT CONDENSING UNIT CYCLES

POSSIBLE CAUSE	VERIFICATION	SOLUTION
Thermostat in Wrong Location	Check that thermostat is in vicinity of return air box.	If necessary, relocate thermostat.
Loose Low Or High Voltage Wiring	Check all wiring connections for tightness.	Tighten all loose connections.
Defective Blower Motor	Check motor as described on page 38 in this manual.	If defective, replace motor.
Condensing Unit	Check according to manufacturer's instructions.	Repair or replace as directed by manufacturer.

CONDITION: SWEATING AT ESP-J UNIT SUPPLY OUTLET

POSSIBLE CAUSE	VERIFICATION	SOLUTION
Air Leak At Supply Air Plenum Adaptor	Check taped joint at adaptor.	Tape joint properly.
Insulation at Outlet Not Installed	Check for insulation at outlet.	Install insulation.

CONDITION: EXCESSIVE NOISE AT TERMINATOR

POSSIBLE CAUSE	VERIFICATION	SOLUTION
High Supply Air Plenum Static Pressure	Check static pressure as described on page 38 in this manual.	Check for and add flow restrictors as necessary in supply runs.
		If necessary, add additional outlets.
Sound Attenuating Tube Not Installed	Check for installation of sound attenuating tube.	Where necessary, install sound attenuating tube.
Tight Radius In Sound Attenuating Tube Or In Supply Tubing	Check all tubing for tight radius.	Where necessary, correct radius.
Incorrect Supply Tubing Length	Check that all supply tubing runs are 9 ft minimum (includes 3 ft sound atten. tube).	Where necessary, correct supply tubing length.
Improperly Balanced System	Check that correct size orifices have been installed.	Properly orifice supply tubing runs.

CONDITION: EXCESSIVE NOISE AT RETURN AIR GRILL

POSSIBLE CAUSE	VERIFICATION	SOLUTION
Return Air Duct Not Installed Properly	Check for minimum 90° bend in return air duct.	Correct bend in return air duct to minimum 90°.
Dirty Return Air Filter	Remove and inspect.	Clean or replace air filter.

CONDITION: EXCESSIVE VIBRATION AT ESP-J UNIT

POSSIBLE CAUSE	VERIFICATION	SOLUTION
Foreign Matter in Blower Wheel	Check for loose or damaged blower wheel.	Replace blower assembly.
Blower Wheel Damaged or Unbalanced	Remove and inspect blower assembly.	Remove any foreign matter and retest fan vibration.

CHECKING ESP-J BLOWER MOTOR

1. With voltmeter, check for selected voltage at input terminals, L1 to N for 115V, L1 to L2 for 230V. Measured voltage should be $\pm 10V$ of selected line voltage.
2. Refer to **SYSTEM START-UP AND ADJUSTMENTS** section. Ensure that the operating speed for the current operating mode is adjusted.

CHECK ESP-J LOW VOLTAGE TRANSFORMER

1. Verify that the unit is configured for the selected line voltage connected to the input terminal strip, 120V or 230V. Refer to **STEP: 7 Wiring the Unit**.
2. Measure the input voltage, either 120V **L1** to **N**, or 230V **L1** to **L2**. Input voltage should be within $\pm 10\%$ of nominal value.
3. If no voltage or voltage outside this range, verify building power supply.
4. If proper voltage is present at the input terminal strip, check transformer secondary voltage for 22-28V across the blue and yellow terminals at the 24VAC terminal strip.
5. If measured voltage is zero, or outside this range, replace the transformer.

CHECK EXTERNAL STATIC PRESSURE

You can use a U-tube manometer to check the external static pressure on the duct system.

1. Puncture a $\frac{1}{4}$ " diameter hole in the plenum duct at least 18" from the fan coil unit.
2. Insert the high-side manometer tube into the hole so that the end is approximately flush with the inside wall of the plenum, and perpendicular to the direction of airflow.
3. System static pressure should be between 1.2" and 1.3" WC.
 - a. If the pressure is higher than 1.2" provide additional supply runs to increase airflow or lower the fan speed by turning the fan speed adjustment for the current mode of operation counter-clockwise to reduce the static pressure.
 - b. If the pressure is lower than 1.2", look for leaks in the supply plenum, restrictions in the return system (including clogged filters) If more than the recommended number of supply runs are installed, you may install flow restrictors (orifices) in these runs. If the number of runs is appropriate for the load, increase the static pressure by turning fan speed adjustment for the current mode of operation clockwise to increase the static pressure.



Service / Troubleshooting FORM "1A"

Customer / Dealer Data:

Name: _____

Address: _____

Tel (day) _____ (eve) _____

Installing Dealer / Contractor:

Name: _____

Tel: _____

Equipment Data:

SPACEPAK Model # ESP / WCSP - _____

SPACEPAK Serial # _____

SPACEPAK Date of Installation: _____

Cond Unit Mfr: _____

Cond Unit Mod #: _____

Rated Capacity: _____ BTUH; SEER: _____

Air-side Data:

Total # of outlets: _____ ; Supply tube length: _____ Ft (avg)
(Please sketch duct layout on reverse side of this sheet, noting all fittings and distances, including return duct size / length)

Air Filter: Size (LxHxD) _____

Type (pleated, etc): _____

Is the filter clean? _____ (Y/N)

Static Pressure (Ps) in supply plenum: _____ "WG
(Measure at approximately 3 ft downstream of blower discharge)

Ps in return duct (downstream of filter, upstream of coil) _____ "WG

SpacePak Motor: Amps (measured): _____ Amps

Voltage (measured): _____ Volts

Air Temperatures:

@ Return (indoor ambient): _____ °FDB; _____ °FWB

@ Condensing unit (outdoor ambient): _____ °F

@ AHU (read 3 ft from fan discharge) _____ °F

@ last supply outlet _____ °F

Refrigeration-side Data:

Line sizes: Liquid _____ Suction _____

Total equivalent length of lines: _____ Ft; Vertical Rise: _____ Ft.

@ Condensing Unit:

Liquid: _____ psi; Temp: _____ °F; Subcool: _____ °F

Suction: _____ psi; Temp: _____ °F; Superheat: _____ °F

@ SpacePak:

Liquid: _____ psi; Temp: _____ °F; Subcool: _____ °F

Suction: _____ psi; Temp: _____ °F; Superheat: _____ °F

Approximate time running before taking readings: _____ Hrs.

Did you adjust the TXV? _____ (Y/N); (If yes, explain): _____

Refrigerant Charge (if weighed-in): _____ lbs

R410a / R22 (circle one)

Installed options: (circle one)

sight glass filter/drier zone controls

Other: _____

Water Data: (where applicable)

Line sizes: _____"; Length: _____ FT

Water temperatures:

Supply: _____ °F; Return _____ °F

Glycol?: _____ (Y/N); % Solution: _____

NOTES: _____

FIGURE 4.1: MODEL ESP-J GENERAL ASSEMBLY

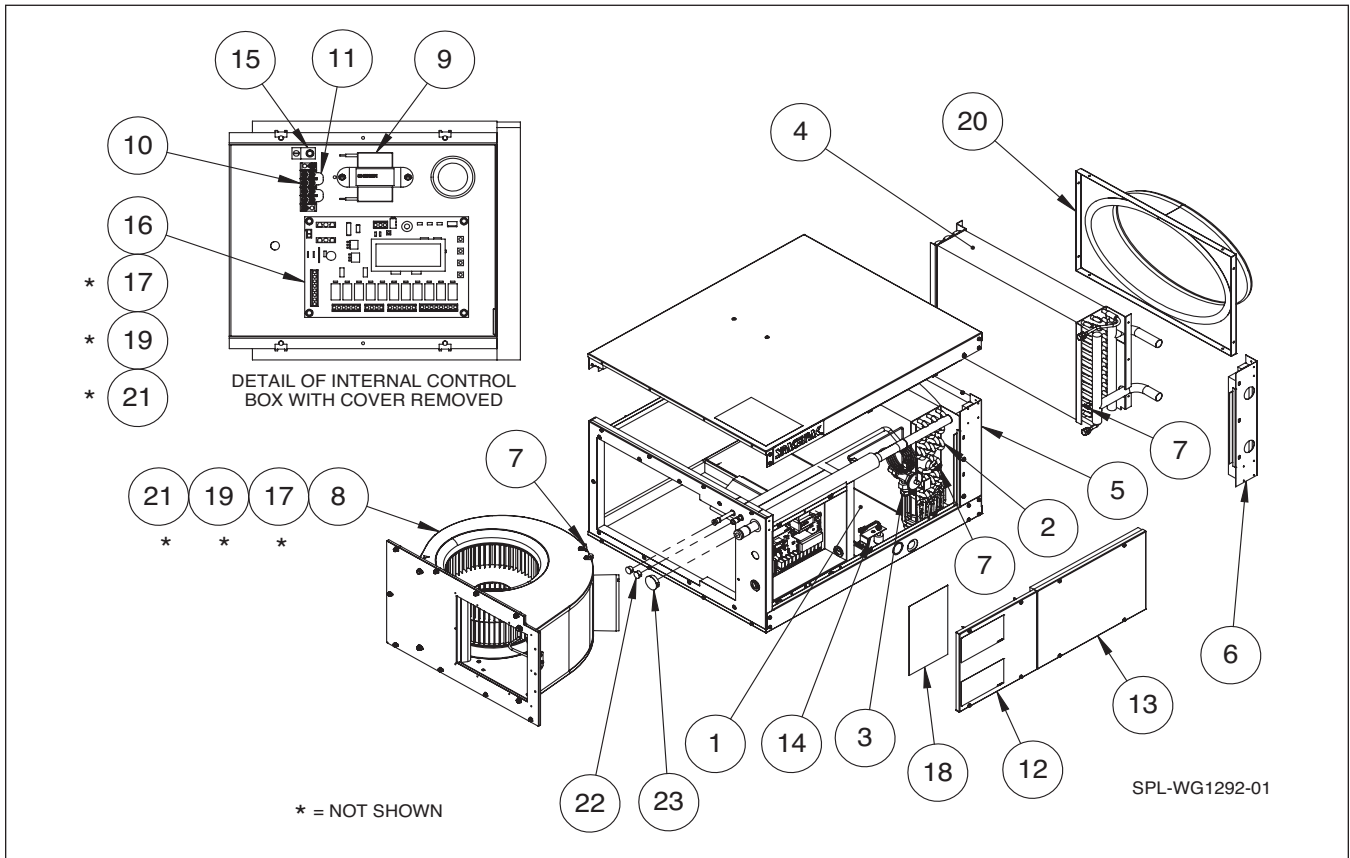

REPLACEMENT PARTS - HORIZONTAL FAN COIL UNITS					
ITEM	PART DESCRIPTION	UNIT SIZE	PART NUMBER	ESP/ WCSP	
1	PRIMARY DRAIN PAN	2430J	W06RWG0220-22	X	X
		3642J	W06RWG0220-23	X	X
		4860J	W06RWG0220-24	X	X
2	R410A COIL ASSEMBLY	2430J	469RWG1270-02	X	
		3642J	469RWG1270-03	X	
		4860J	469RWG1270-04	X	
3	THERMAL EXPANSION VALVE, CHATLEFF CONNECTION	2430J	W28RWG0641-02	X	
		3642J	W28RWG0641-03	X	
		4860J	W28RWG0641-04	X	
4	HYDRONIC COIL ASSEMBLY	2430J	469RWG1267-02		X
		3642J	469RWG1267-03		X
		4860J	469RWG1267-04		X
5	CORNER POST ESP COIL	ALL SIZES	462RWG0530-01	X	
6	CORNER POST WCSP COIL	ALL SIZES	462RWG0573-01		X
7	TEMPERATURE SENSOR	ALL SIZES	W09RWG1257-01	X	X
8	BLOWER ASSEMBLY	ALL SIZES	W35RWG0802-10	X	X
9	TRANSFORMER	ALL SIZES	W14RWG1234-01	X	X
10	TERMINAL BLOCK	ALL SIZES	W09RWG1263-04	X	X
11	JUMPER, TERMINAL BLOCK	ALL SIZES	W09RWG1264-01	X	X
12	ELECTRICAL CONTROL BOX COVER	ALL SIZES	462RWG1245-01	X	X
13	COIL ACCESS PANEL	ALL SIZES	462RWG0914-01	X	X
14	PRIMARY FLOAT SWITCH	ALL SIZES	460RWG0543-01	X	X
15	CABLE CONNECTOR (GROUND)	ALL SIZES	W09RWG0313-01	X	X
16	J+ CONTROL BOARD (BLACK)	ALL SIZES	W11RWG1242-01	X	X
17	WIRE HARNESS, MOTOR CONTROL	ALL SIZES	460RWG1235-01	X	X
18	WIRING DIAGRAM	ALL SIZES	W49RWG1282-01	X	X
19	BLOWER SPEED CONTROL CABLE	ALL SIZES	W11RWG0807-01	X	X
20	RETURN AIR PANEL ASSEMBLY	2430J	463RWG0708-02	X	X
		3642J	463RWG0708-03	X	X
		4860J	463RWG0708-04	X	X
21	SILICONE TUBING, 3/16 ID	ALL SIZES	H07R01471-002	X	X
22	SNAP PLUG, 5/8 ID	ALL SIZES	JO7R01019-015		X
23	SNAP PLUG, 1-3/8 ID	ALL SIZES	JO7R01019-037		X

FIGURE 4.2: MODEL ESP-JV GENERAL ASSEMBLY

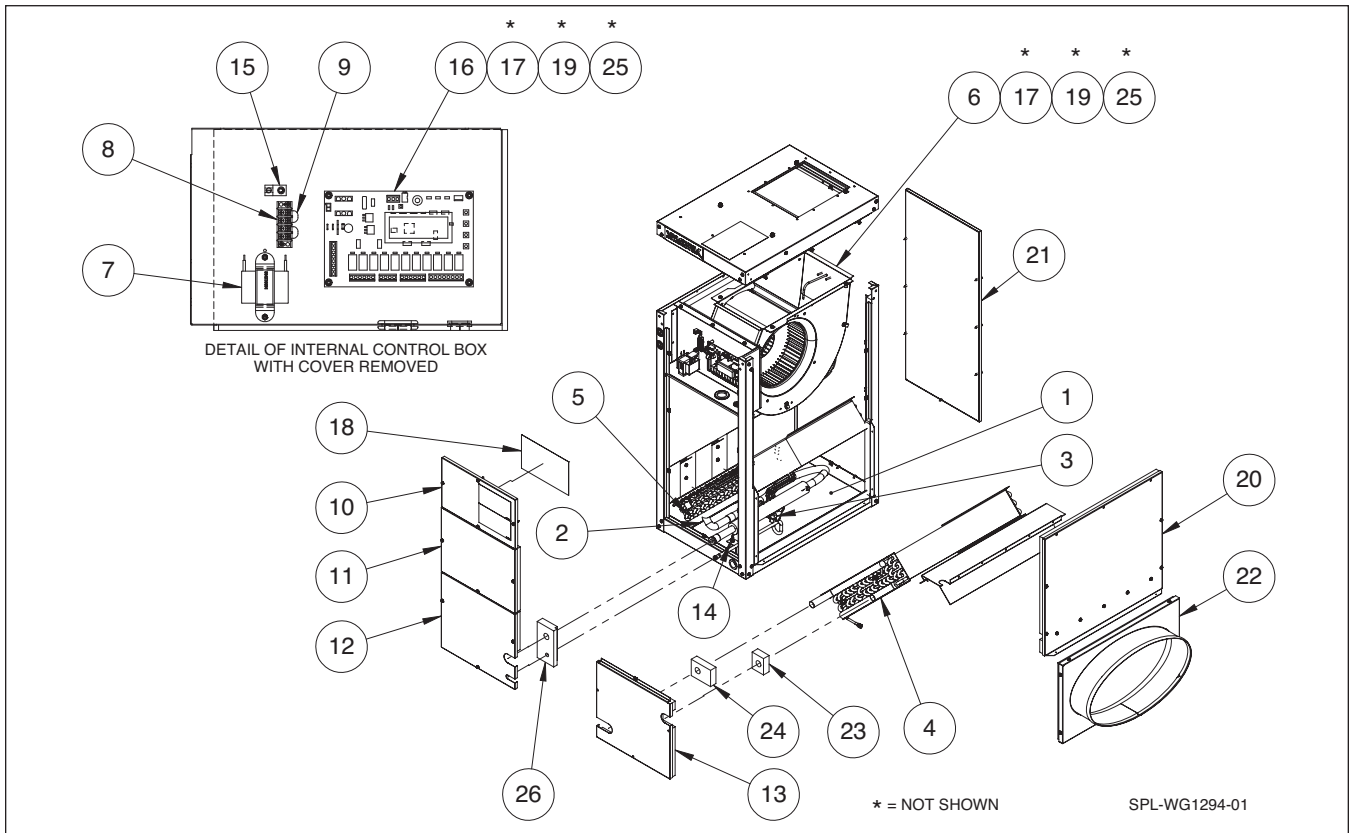

REPLACEMENT PARTS - VERTICAL FAN COIL UNITS					
ITEM	PART DESCRIPTION	UNIT SIZE	PART NUMBER	ESP	WCSP
1	PRIMARY DRAIN PAN ASSEMBLY	2430J	W06RWG1012-02	X	X
		3642J	W06RWG1012-03	X	X
		4860J	W06RWG1012-04	X	X
2	R410A COIL ASSEMBLY	2430J	469RWG1252-02	X	
		3642J	469RWG1252-03	X	
		4860J	469RWG1252-04	X	
3	THERMAL EXPANSION VALVE, CHATLEFF CONNECTION	2430J	W28RWG0641-02	X	
		3642J	W28RWG0641-03	X	
		4860J	W28RWG0641-04	X	
4	HYDRONIC COIL ASSEMBLY	2430J	469RWG1268-02		X
		3642J	469RWG1268-03		X
		4860J	469RWG1268-04		X
5	TEMPERATURE SENSOR	ALL SIZES	W09RWG1257-01	X	X
6	BLOWER ASSEMBLY	ALL SIZES	W35RWG0802-10	X	X
7	TRANSFORMER ASSEMBLY	ALL SIZES	W14RWG1234-01	X	X
8	TERMINAL BLOCK	ALL SIZES	W09RWG1263-04	X	X
9	JUMPER, TERMINAL BLOCK	ALL SIZES	W09RWG1264-01	X	X
10	ELECTRICAL CONTROL BOX COVER	ALL SIZES	462RWG1247-01	X	X
11	CENTER ACCESS PANEL ASSEMBLY	ALL SIZES	458RWG0975-01	X	X
12	ACCESS PANEL, R410A COIL	ALL SIZES	458RWG0725-01	X	
13	ACCESS PANEL, HYDRONIC COIL	ALL SIZES	458RWG0665-01		X
14	PRIMARY FLOAT SWITCH	ALL SIZES	455RWG1009-01	X	X
15	CABLE CONNECTOR (GROUND)	ALL SIZES	W09RWG0313-01	X	X
16	J+ CONTROL BOARD (BLACK)	ALL SIZES	W11RWG1242-01	X	X
17	WIRE HARNESS, MOTOR CONTROL	ALL SIZES	460RWG1235-01	X	X
18	WIRING DIAGRAM	ALL SIZES	W49RWG1282-01	X	X
19	BLOWER SPEED CONTROL CABLE	ALL SIZES	W11RWG0807-01	X	X
20	BLOWER ACCESS PANEL ASSEMBLY	2430J	462RWG0691-02	X	X
		3642J	462RWG0691-03	X	X
		4860J	462RWG0691-04	X	X
21	SIDE ACCESS PANEL ASSEMBLY	ALL SIZES	462RWG1007-01	X	X
22	RETURN AIR PANEL ASSEMBLY	2430J	463RWG0709-02	X	X
		3642J	463RWG0709-03	X	X
		4860J	463RWG0709-04	X	X
23	INSULATION, UPPER COIL TUBE	ALL SIZES	Y06RWG0663-01		X
24	INSULATION, LOWER COIL TUBE	ALL SIZES	Y06RWG0663-02		X
25	TUBING, HI-TEMP, 3/16" ID	ALL SIZES	H07R01471-002	X	X
26	INSULATION, COIL TUBE	ALL SIZES	Y06RWG0726-01	X	



LIMITED WARRANTY STATEMENT

SpacePak “Solstice Inverter”* Series Air to Water Heat Pumps

Subject to the terms and conditions of this Limited Warranty Statement (the “Limited Warranty”), SpacePak warrants to the original purchaser of the “Solstice Inverter” Series that:

- 1) The parts are warranted for a period of two (2) years to the original owner of the System (as such term is defined in part (4) below). If any parts should prove defective due to improper workmanship and/or material for a period of two (2) years from the date of installation, SpacePak will replace any defective part without charge for that part. Replacement parts are warranted for the remainder of the original 2-year warranty period. Parts used as replacement may be of like kind and quality and may be new or remanufactured. Defective parts must be available for SpacePak in exchange for the replacement parts and become the property of SpacePak.
- 2) The compressor is warranted for a period of five (5) years to the original owner of the System. If the compressor should prove defective due to improper workmanship and/or material for a period of five (5) years from the date of installation, SpacePak will replace the defective compressor without charge for the compressor. Replacement compressors are warranted for the remainder of the original 5-year warranty period. Compressors used for replacement may be of like kind and quality and may be new or remanufactured. Defective compressors must be made available to SpacePak in exchange for the replacement compressor and become the property of SpacePak.
- 3) Notwithstanding the foregoing, if the System is installed in a residential single-family home by a SPACEPAK CERTIFIED CONTRACTOR the parts will be warranted for five (5) years and compressor will be warranted for a period of ten (10) years, to the original owner, so long as the original owner resides in the home. Specifically, if any parts and/or the compressor should prove defective due to improper workmanship and/or material for the period listed above from the date of installation, SpacePak will replace any defective parts or compressor without charge for the part or compressor. The replacement parts and/or compressor are warranted for the remainder of the original warranty period. Parts and/or compressors used for replacement may be of like kind and quality and may be new or remanufactured. Defective parts and/or compressors must be made available to SpacePak in exchange for the replacement parts and become the property of SpacePak.
- 4) For purposes of this Solstice Inverter” Series Limited Warranty, as used herein, the term “System” shall mean the Solstice Inverter outdoor and indoor components connected via refrigerant piping and electrical wiring purchased on or after February 1, 2021, (i) sold from a licensed HVAC representative of SpacePak (and not an unauthorized third party) to the original owner, (ii) installed by such contractor in accordance to local and National regulations in the continental U.S., Alaska, Hawaii, and Canada; and (iii) registered on SpacePak’s website located at www.SpacePak.com/warranty)

*For any Solstice equipment that is non-inverter, please refer to warranty located in the equipment original installation manual.

SpacePak Small Duct High Velocity Air Handlers and Hydronic Fan Coils

Subject to the terms and conditions of this Limited Warranty Statement (the “Limited Warranty”), SpacePak warrants to the original purchaser of the Small Duct High Velocity Air Handlers and hydronic fan coils that:

- 1) The parts are warranted for a period of one (1) year to the original owner of the System (as such term is defined in part (3) below). If any parts should prove defective due to improper workmanship and/or material for a period of one (1) year from the date of installation, SpacePak will replace any defective part without charge for that part. Replacement parts are warranted for the remainder of the original 1-year warranty period. Parts used as replacement may be of like kind and quality and may be new or remanufactured. Defective parts must be available for SpacePak in exchange for the replacement parts and become the property of SpacePak.
- 2) Notwithstanding the foregoing, if the System is installed in a residential single-family home by a SPACEPAK CERTIFIED CONTRACTOR the parts will be warranted for five (5) years, to the original owner, so long as the original owner resides in the home. Specifically, if any parts should prove defective due to improper workmanship and/or material for the period listed above from the date of installation, SpacePak will replace any defective parts or compressor without charge for the part or compressor. The replacement parts are warranted for the remainder of the original warranty period. Parts used for replacement may be of like kind and quality and may be new or remanufactured. Defective parts must be made available to SpacePak in exchange for the replacement parts and become the property of SpacePak.
- 3) For purposes of this Small Duct High Velocity Air Handlers and hydronic fan coils limited warranty, as used herein, the term “System” shall mean the “SpacePak Small Duct High Velocity Air Handlers, hydronic fan coils purchased on or after February 1, 2021, (i) sold from a licensed HVAC representative of SpacePak (and not an unauthorized third party) to the original owner, (ii) installed by such contractor in accordance to local and National regulations in the continental U.S., Alaska, Hawaii, and Canada; and (iii) registered on SpacePak’s website located at www.SpacePak.com/warranty)

SpacePak Buffer Tanks

The “Manufacturer” warrants to the original owner at the original installation site that the Hydronic Buffer Tanks (the “Product”) will be free from defects in material or workmanship for a period not to exceed ten (10) years from the startup, provided the product is installed in accordance with the manufacturers installation instructions. If upon examination by the Manufacturer the Product is shown to have a defect in material or workmanship during the warranty period, the Manufacturer will repair or replace, at its option, that part of the Product which is shown to be defective.

The following items apply to each Limited Warranty offered by SpacePak.

- 4) **NO LABOR.** Each Limited Warranty offered by SpacePak does NOT include labor or any other costs incurred for service, maintenance, repair, removing, replacing, installing, complying with local building and electric codes, shipping or handling, or replacement of the System/Products, compressors or any other parts. For items that are designed to be maintained or replaced by the original owner, the original owner is solely responsible for all labor and other costs of maintaining, installing, replacing, disconnecting or dismantling the System/ Products and parts in connection with owner-required maintenance. Please consult the applicable technical documentation for regularly suggested maintenance procedures.
- 5) **PROPER INSTALLATION.** This Limited Warranty applies only to Systems/Products that are sold by SpacePak HVAC representatives, installed by contractors who are licensed for HVAC installation under applicable local and state law, and who install the Systems/Products in accordance with (i) all applicable building codes and permits: (ii) SpacePak’s installation and operation instructions: and (iii) good trade practices.
- 6) **BEFORE REQUESTING SERVICE,** please review the applicable technical documentation to insure proper installation and correct customer control adjustment for the System/Products. If the problem persists, please arrange for warranty service.
 - a. **TO OBTAIN WARRANTY SERVICE:**
 - i. Contact the licensed contractor who installed the System/Products or the nearest licensed contractor, dealer, or distributor (whose name and address may be obtained on our website at www.SpacePak.com of any defect within the applicable warranty time period.
 - ii. Proof of the installation date by a licensed contractor is required when requesting warranty service. Present the sales receipt, building permit or other document which establishes proof and date of installation. In the absence of acceptable proof, this Limited Warranty shall be deemed to begin one hundred twenty (120) days after the date of manufacture stamped on the System/Products.
 - iii. This Limited Warranty applies only to System/Products purchased on or after February 1, 2021 only while the System/Products remains at the site of the original installation, and only to locations within the continental United States, Alaska, Hawaii and Canada.
 - iv. Shipment, to the Manufacturer, of that part of the Product thought to be defective. Goods can only be returned with prior written approval from the Manufacturer. All returns must be freight prepaid. Determination, in the reasonable opinion of the Manufacturer, that there exists a defect in material or workmanship.
 - b. **THIS LIMITED WARRANTY DOES NOT COVER:** property damages, malfunction or failure of the System/Products, or personal injury caused by or resulting from: (a) accident, abuse, negligence or misuse; (b) operating the System/Products in a corrosive or wet environment, including those containing chlorine, fluorine or any other hazardous or harmful chemicals or environmental factors, including sea- or salt-water; (c) installation, alteration, repair or service by anyone other than a licensed contractor or other than pursuant to the manufacturer’s instructions; (d) improper matching of System/Products components; (e) improper sizing of the System/Products; (f) improper or deferred maintenance contrary to the manufacturer’s instructions; (g) physical abuse to or misuse of the System/Products (including failure to perform any maintenance as described in the Operation manual, or any System/ Products damaged by excessive physical or electrical stress; (h) System/Products that have had a serial number or any part thereof altered, defaced or removed; (i) System/Products used in any manner contrary to the Operation Manual; (j) freight damage; or (k) events of force majeure or damage caused by other external factors such as lightning, power surges, fluctuations in or interruptions of electrical power, rodents, vermin, insects, or other animal- or pest-related issues.
 - c. **THIS LIMITED WARRANTY ALSO EXCLUDES:** (a) SERVICE CALLS WHERE NO DEFECT IN THE SYSTEM/PRODUCTS COVERED UNDER THIS WARRANTY IS FOUND: (b) System/Products installation or set-ups; (c) Adjustments of user controls; (d) System/Products purchased or installed outside the continental United States, Alaska, Hawaii and Canada; or (e) System/Products purchased or installed prior to **February 1, 2021**. Consult the operating instructions for information regarding user controls.



IN UNITED STATES: 260 NORTH ELM ST. WESTFIELD, MA 01085 (413) 564-5530/FAX (413) 564-5815
IN CANADA: 7555 TRANMERE DRIVE, MISSISSAUGA, ONTARIO, L5S 1L4 (905) 670-5888/FAX (905) 670-5782