

Since 1949
Slant/Fin[®]
BASEBOARD

HD-850

Heavy-Duty 16-Gauge, Slope Top Baseboard Heating



Ideal for Sites Where
RUGGED TREATMENT
is Anticipated



HD-850

Heavy-Duty Baseboard

The exceptional strength of HD-850 baseboard makes it ideal for installation in sites where rugged treatment is anticipated. HD-850 is highly recommended for rental properties, military housing, schools, institutions, and public housing. Its compact size and high output make it suitable for a wide range of new and retrofit applications. In addition to heavy gauge enclosure and support brackets, HD-850 baseboard cover is secured in place with self tapping at each bracket location.

Features

- Heavy gauge enclosure including 16-gauge front cover
- Durable support bracket welded to back panel
- Screw fastens front cover directly to support brackets every 12 inches (304mm)
- Six heating elements selection
- Nu-White pre-painted finish
- Fully assembled and factory packaged (Elements shipped separately)



HD-850

Interchangeable Heating Elements

A choice of six heating elements provides a range of output and capacity to closely match HD-850 baseboard to job requirements. 1" (25mm) and 1-1/4" (32mm) copper/aluminum elements permit higher flow rates, longer series-loop runs and lower pump loads where required. With the 1-1/4" (32mm) all-steel element, HD-850 is ideal for use in one or two pipe steam systems.

Ratings

Model Number	Element Type	Tube Size & Material	Aluminum Fin Size	Fins Per Foot	Water Flow	Pressure Drop(1)	Steam PSI Btu/Hr. Per Foot	HOT WATER RATINGS*											
								BTU/HR/FT. (Flow Rate 3 Ft./Sec.)											
								110° F 43° C	120° F 49° C	130° F 54° C	140° F 60° C	150° F 66° C	160° F 71° C	170° F 77° C	180° F 82° C	190° F 88° C	200° F 93° C	210° F 99° C	220° F 104° C
HD-850	H-1	3/4" (19mm) Copper	3 1/4" x 3 1/4" x .018" (82mm x 82mm x .46mm)	48	1 GPM	47	N/A	190	260	320	390	470	550	640	720	800	890	970	1050
					4 GPM	525		210	280	350	420	500	580	680	760	850	940	1030	1110
	H-3	3/4" (19mm) Copper	2 3/4" x 2 1/2" x .010" (70mm x 64mm x .25mm)	60	1 GPM	47	N/A	170	230	290	350	420	490	570	640	720	790	870	940
					4 GPM	525		180	240	300	370	440	520	600	680	760	840	920	990
	H-4	1" (25mm) Copper	3 1/4" x 3 1/4" x .018" (82mm x 82mm x .46mm)	55	1 GPM	13	N/A	170	230	280	340	410	460	560	630	710	780	860	1030
					4 GPM	145		180	240	300	360	430	500	590	670	750	830	1000	1080
	H-2	1" (25mm) Copper	2 3/4" x 2 1/2" x .010" (70mm x 64mm x .28mm)	55	1 GPM	13	N/A	180	240	290	350	420	530	580	660	740	830	900	980
					4 GPM	145		190	250	310	380	450	550	620	700	780	860	960	1050
	H-5	1-1/4" (32mm) Copper	3 1/4" x 3 1/4" x .018" (82mm x 82mm x .46mm)	48	1 GPM	6	1160	180	240	300	360	430	550	600	680	770	860	920	1010
					4 GPM	63		190	250	320	390	460	560	640	710	810	880	980	1070
	H-6	1-1/4" (32mm) IPS Steel	3 1/4" x 3 1/4" x .026" (82mm x 82mm x .66mm)	48	1 GPM	3	980	150	200	250	300	360	440	510	570	640	710	780	850
					4 GPM	41		150	200	260	310	370	450	540	600	680	750	830	900

* Based on 65° F (18° C) entering air temperature

(1) Millinches per foot.

Note: Ratings are based on active finned length (3" (76mm) less than overall length), and include 15% heating effect factor.

Use 4 GPM ratings only when flow is known to be equal to or greater than 4 GPM; otherwise 1 GPM

Dimensions

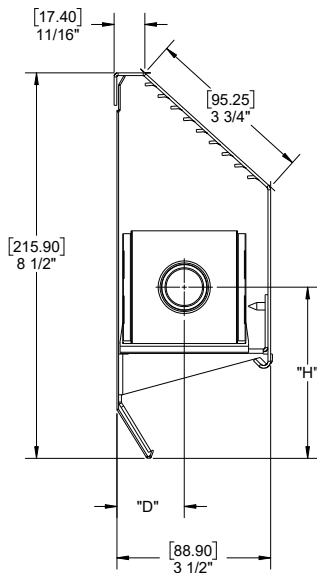

Element	"H"		"D"	
H-1	4-1/16"	103mm	1-3/4"	44mm
H-2, H-3, H-4	3-5/8"	92mm	1-5/8"	48mm
H-5	4"	102mm	1-3/4"	44mm
H-6	4"	102mm	1-3/4"	44mm

Ordering Data

PACKAGING: Complete two-piece enclosure assembly factory packaged with necessary brackets and hangers. Order element separately.

CONSTRUCTION: Full back panel with interlocking slope top front panel. Pencil-proof louvers. Bracket with element guide spot welded to back panel every 24" (610mm) alternating with cabinet spacer welded to back panel every 24" (610mm) giving rigid support to front every 12" (305mm). There are dimpled anchoring holes every 12" (305mm). For fastening front to brackets, use 8 x 1/2 self tapping screws with countersunk head as supplied with cover.

DEPTH: 3-1/2" (89mm)

HEIGHTS: 8-1/2" (216mm) (one tier)

LENGTHS: 2' (.6m), 3' (.9m), 4' (1.2m), 5' (1.8m), 6' (1.8m), 7' (2.1m), 8' (2.4m).

MATERIAL: 16-gauge steel front cover, 20-gauge back panel.

FINISH: CRS in Nu-White is standard.

ELEMENTS: Choice of six elements. Copper with aluminum fins: H-1, H-2, H-3, H-4, H-5. Steel with aluminized steel fins: H-6. Lengths from 2' (.6m) to 8' (2.4m) feet.

JOINTS: Snap on accessories eliminate the need to perfectly butt one length of cover to the next, reducing need for field cutting. Critical linear and vertical tolerances are eliminated because the snap on accessories absorb misalignment issues that might result from uneven floors and walls.

HD-850

Accessories

HINGED

End Cap 4" (101.6mm)



Slotted End Cap 4" (101.6mm)



Inside Corner 90°



Inside Corner 135°

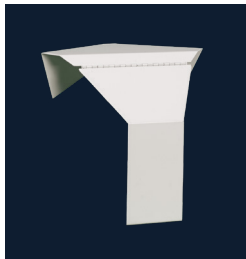

Valve Cover 10" (254mm)



Slotted Valve Cover 10" (254mm)



Center Valve Cover 10" (254mm)



NON-HINGED

End Cap 2" (50.8)



Splice Plate 2" (50.8),
3" (76.2mm) & 4" (101.6mm)



Filler Sleeve 7" (177.8mm)



Outside Corner 90° & 135°



ADDITIONAL ACCESSORIES

- Wall Trim 4" (101.6mm)
- Support Bracket
- Plastic Expansion Cradle

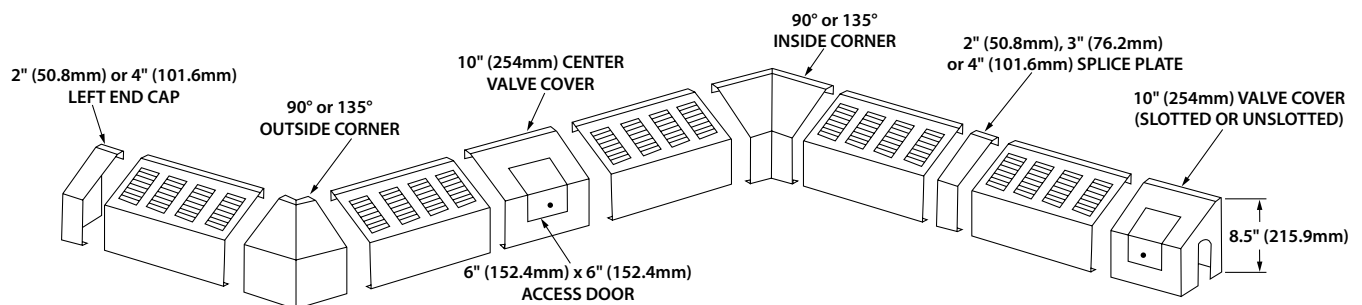

10 Hub Drive
Melville, NY 11747
Phone: 631-694-1800

7555 Tranmere Drive
Mississauga, Ontario, L5S 1L4
Phone: 905-670-5888

www.slantfinbaseboard.com

