

TORUS 1500 VERTICAL

Category II or Category IV Appliance

(see Installation and Operation Manual for venting information)

CODE OPTIONS

CSD-1

FIRMWARE W/REMOTE
TEST MANUAL RESET LWCO

INDOOR UNIT

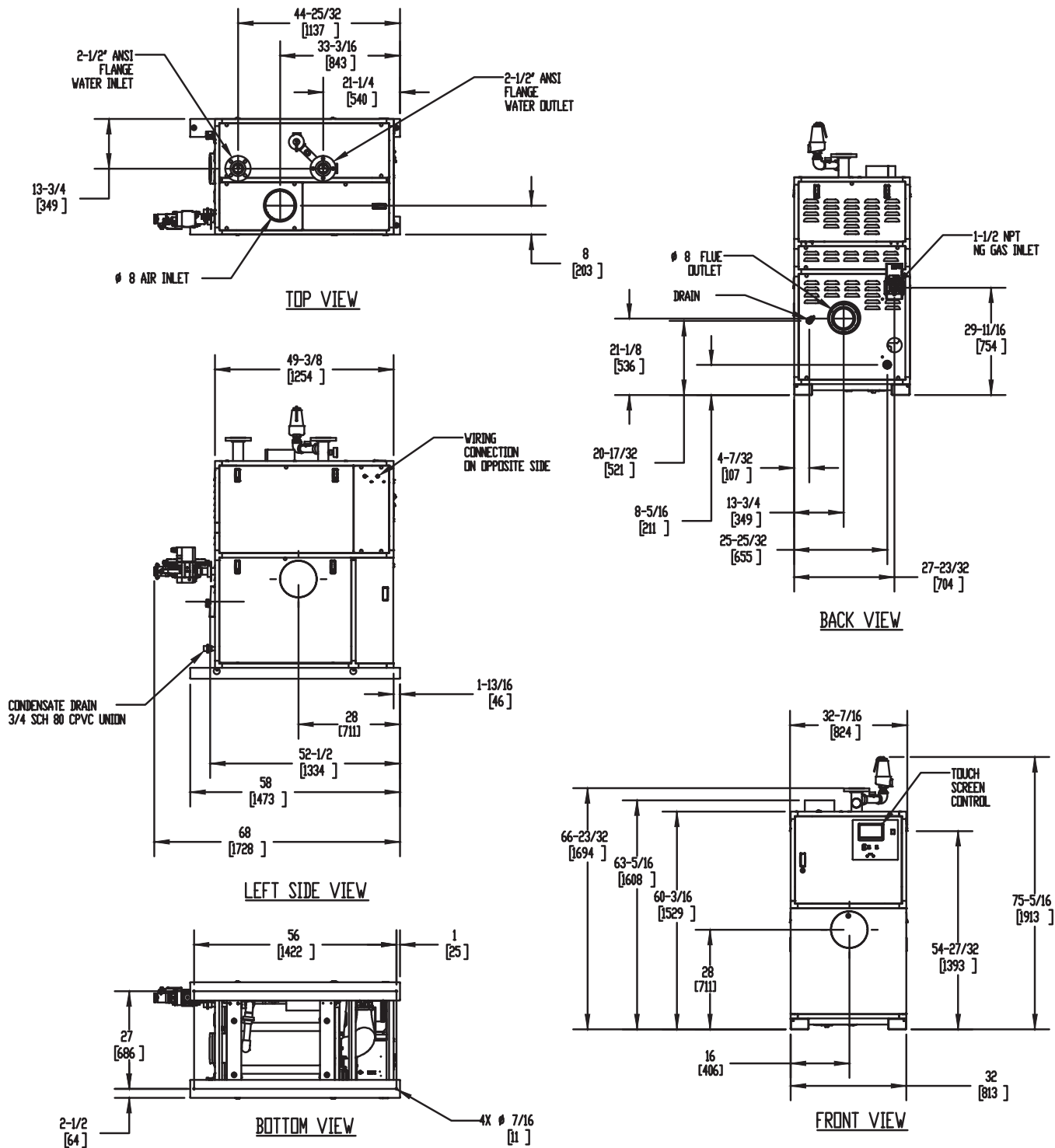

Notes:

1. Dimensions are approximate and should not be used to "rough-in" equipment.
2. Dimensions are subject to change without notice.
3. All dimensions are in inches (mm).
4. Symbol indicates center of gravity.

TORUS 1500 VERTICAL

Category II or Category IV Appliance
(see Installation and Operation Manual for venting information)

CODE OPTIONS

CSD-1

FIRMWARE W/REMOTE
TEST MANUAL RESET LWCO

DUAL FUEL UNIT

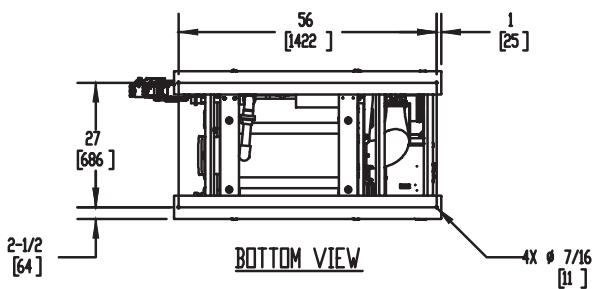
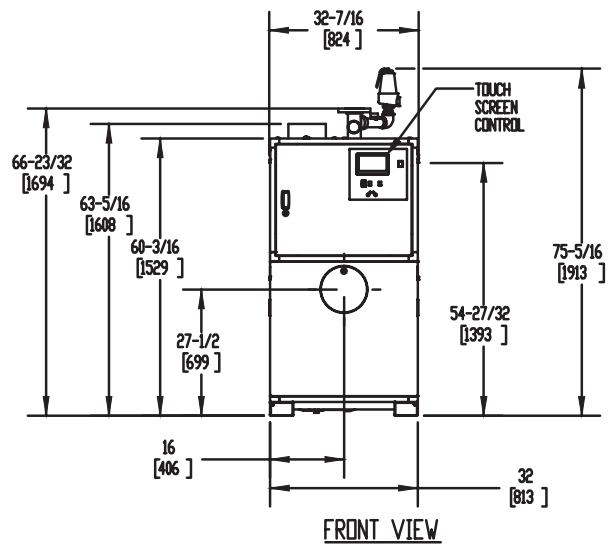
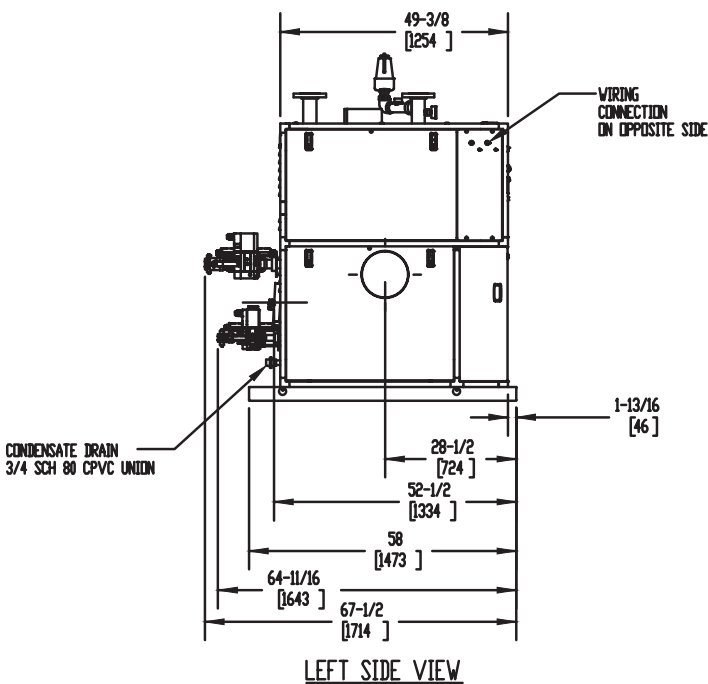
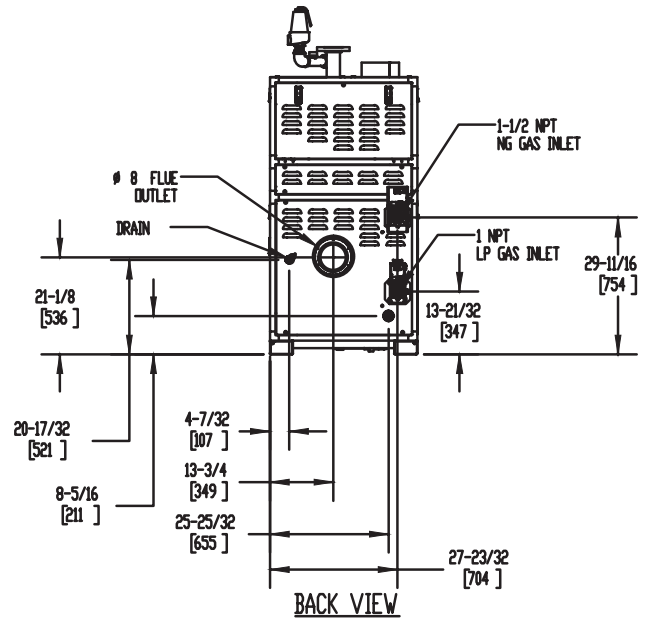
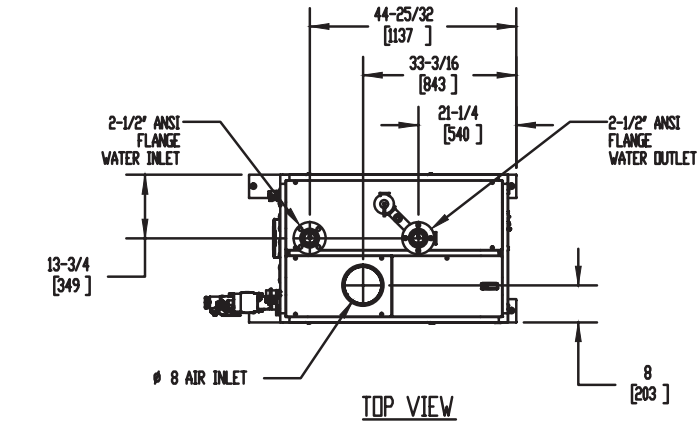

Notes:

1. Dimensions are approximate and should not be used to "rough-in" equipment.
2. Dimensions are subject to change without notice.
3. All dimensions are in inches (mm).
4. ● Symbol indicates center of gravity.

BOILER CERTIFIED RATINGS & CAPACITIES

Fuel Type	Natural/Propane Gas	Boiler FLA	21.0*
Input BTU/hr.	1,500,000 / 440 kW	Boiler HP	43.25
Output BTU/hr.	1,447,500 / 424 kW	Min. Gas Pressure Required	4" W.C.
Electrical Requirements	120 VAC/60 Hz/1PH	Max. Gas Pressure Allowed	14" W.C.
		Operating Weight	1183 lbs / 537 kg

BOILER TRIM & CONTROLS

Main Gas Valve	Dungs MBC	Air Switch	Huba
Firing Valve	1" Apollo	Flow Switch	SIKA
Ignition Control	Fenwal	Blocked Flue Switch	Cleveland NS2
Operating Control	HeatNet®	Blower Motor	Ametek
High Limit	Jumo	L.W.C.O.	800
Main Ball Valve	1 1/2" Apollo	Relief Valve (WB)	1" x 1-1/4" set @ 50 psi
		Relief Valve (WW)	1" x 1" set @ 125 psi

Pump contactor strongly recommended for water heater applications.

A.S.M.E.

ASME Sect IV Fire Side Htg Surface	119.8 Sq. Ft. / 11.13 Sq. M.	Design Data	Max. 160 psig & 210°F
ASME Sect IV Water Side Htg Surface	111.08 Sq. Ft. / 10.32 Sq. M.	Water Volume	13 gal. / 49.2 Liters
		pH Level	6.5-8.5

* Add circulator amps.

BOILER TEMPERATURE RISE / PRESSURE DROP (Based on Full Input)

20°F / 11.1°C				30°F / 16.7°C				40°F / 22.2°C				50°F / 27.8°C				60°F / 33.3°C			
Flow Rate		Pressure Drop		Flow Rate		Pressure Drop		Flow Rate		Pressure Drop		Flow Rate		Pressure Drop		Flow Rate		Pressure Drop	
GPM	L/s	Ft	kPa	GPM	L/s	Ft	kPa	GPM	L/s	Ft	kPa	GPM	L/s	Ft	kPa	GPM	L/s	Ft	kPa
144.8	9.1	16.4	49.0	96.5	6.1	8.1	24.2	72.4	4.6	5.0	14.9	57.9	3.7	3.5	10.4	48.3	3.0	2.6	7.8
Flow GPM (Boiler)				Temp. Rise (°F) (Boiler**)				Vent Length (Equiv. Ft.)				Air Inlet Length (Equiv. Ft.)							
Min		Max		Min		Max		Min		Max		Min		Max					
48.3		144.8		20		60		8		160		0		160					

** Min/Max delta t reflects boiler operation at full input. For applications requiring operation above/below these parameters please consult factory.

WATER HEATER HOURLY RECOVERY CAPACITY (GPH & LPH)

40°F	22°C	60°F	33°C	80°F	44°C	100°F	56°C	120°F	67°C	140°F	78°C
4367	16506	2911	11004	2183	8253	1747	6603	1456	5502	1248	4716

Water Heater Min Flow Rates

Normal (4 to 12) gpg				Hard (12 to 15) gpg			
Flow Rate		Pressure Drop		Flow Rate		Pressure Drop	
gpm	L/s	Ft	kPa	gpm	L/s	Ft	kPa
110.0	6.9	10.1	30.2	147.0	9.3	16.8	50.2

REP FIRM _____
SUBMITTED BY _____
JOB NAME _____
ARCHITECT _____
ENGINEER _____
CONTRACTOR _____
DATE _____

TORUS 1500 VERTICAL

Category II or Category IV Appliance
 (see Installation and Operation Manual for venting information)



A Division of Mestek, Inc.
 Westfield, MA 01085
 (413) 564-5515