

SPECTRUM 300

Category I Appliance

Must be vented into a negative pressure vent system.

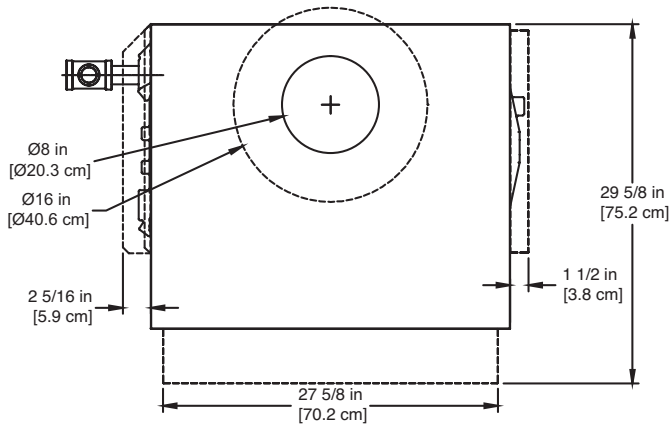

TOP

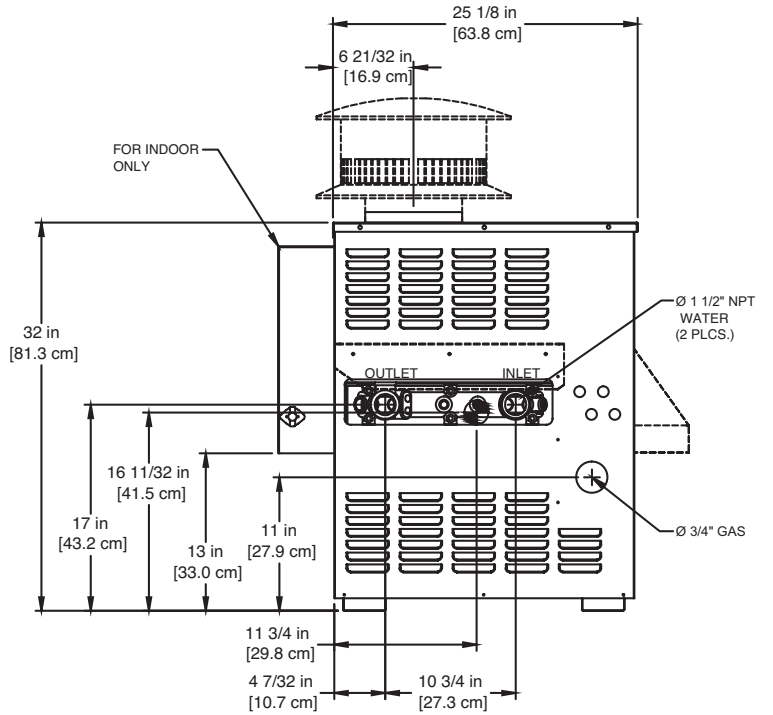

LEFT SIDE

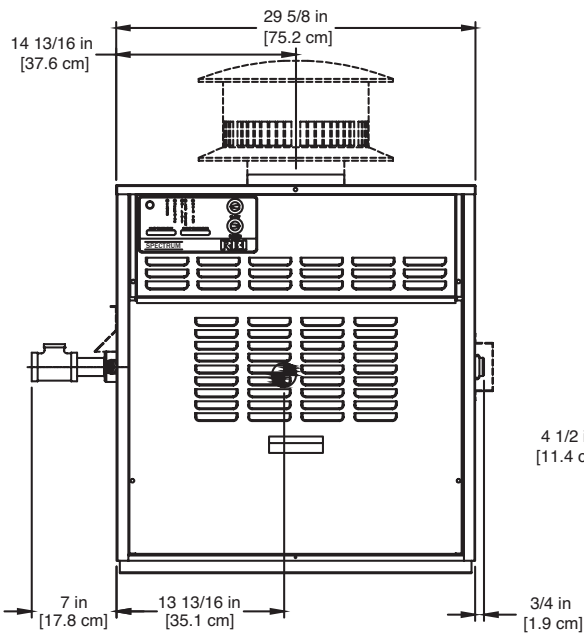

FRONT

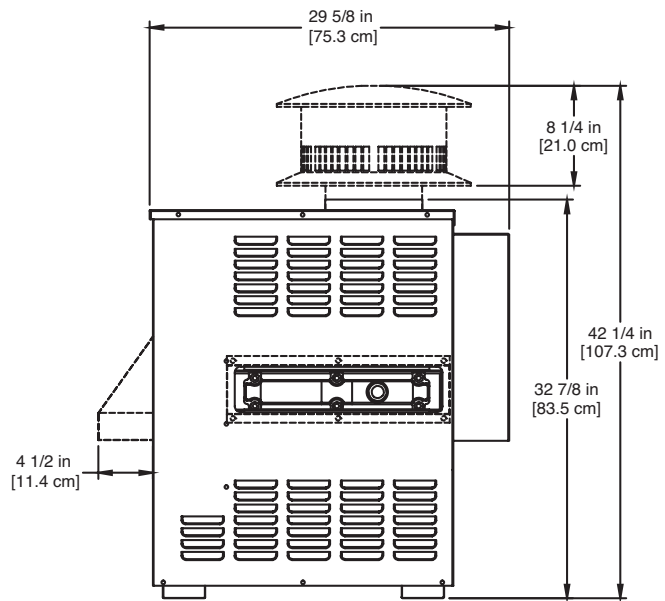

RIGHT SIDE

NOTE:
----- FOR OUTDOOR ONLY

RSUB-5-C

Notes:

1. Dimensions are approximate and should not be used to "rough-in" equipment.
2. Dimensions are subject to change without notice.

BOILER CERTIFIED RATINGS & CAPACITIES

Fuel Type	Natural/Propane Gas	Boiler FLA	1*
Input BTU/hr.	301,000 / 88 kW	Min. Gas Pressure Required	5" WC**
Output BTU/hr.	246,820 / 72 kW	Max. Gas Pressure Allowed	14" WC
Electrical Requirements	120VAC / 1 ph / 60 hz	Operating Weight	232 lbs. / 105 kg.

BOILER / WATER HEATER TRIM & CONTROLS

Gas Valve - INT	Honeywell VR8304M 3/4"	Ignition Control (SB On/Off)	Honeywell S9361A2085
Gas Valve	Honeywell VR8304Q 3/4" - 2 Stg.	Ignition Control (SB 2 Stg.)	Honeywell S86IOM
Operating Control (SB/SW)	Honeywell - On/Off	Ignition Control (SW)	Honeywell S86IOM
Operating Control (SB)	Jumo - 2 Stage	Relief Valve - SW	3/4" x 3/4" set @ 125 psi
High Limit (SB/SW)	Jumo	Relief Valve - SB	3/4" x 3/4" set @ 30 psi
		Flow Switch	TACO

A.S.M.E.

ASME Sect IV Htg Surface	42.5 Sq. Ft. / 3.95 Sq. M.	Design Data	Max. 160 psig & 250°F
Water Volume	1.4 gal / 5.11 Liters		

* Add circulator amps.

** For incoming gas pressures lower than 5" WC natural or 11" WC propane, consult factory.

BOILER TEMPERATURE RISE / PRESSURE DROP

10°F / 5.5°C				20°F / 11.1°C				30°F / 16.7°C				
Flow Rate		Pressure Drop		Flow Rate		Pressure Drop		Flow Rate		Pressure Drop		
GPM	L/s	Ft	kPa	GPM	L/s	Ft	kPa	GPM	L/s	Ft	kPa	
49.4	3.1	0.80	2.4	24.7	1.6	0.22	0.7	16.5	1.0	0.10	0.3	2 Pass
49.4†	3.1†	5.79	17.1	24.7	1.6	1.60	4.7	16.5	1.0	0.80	2.2	4 Pass

† Flow exceeds recommended maximum use a greater temperature rise or consult manufacturer.
Cupronickel heat exchanger should be considered.

WATER HEATER HOURLY RECOVERY CAPACITY (GPH & LPH)

40°F	22°C	60°F	33°C	80°F	44°C	100°F	56°C	120°F	67°C	140°F	78°C
720	2723	480	1815	360	1361	288	1089	240	908	206	778

REP FIRM _____
SUBMITTED BY _____
JOB NAME _____
ARCHITECT _____
ENGINEER _____
CONTRACTOR _____
DATE _____

SPECTRUM 300

Category I Appliance

Must be vented into a negative pressure vent system.

RBI®
 RELIABLE. BOLD. INNOVATIVE.

A Division of Mestek, Inc.
 Westfield, MA 01085
 (413) 568-9571