

# SPECTRUM 250

## Category I Appliance

Must be vented into a negative pressure vent system.

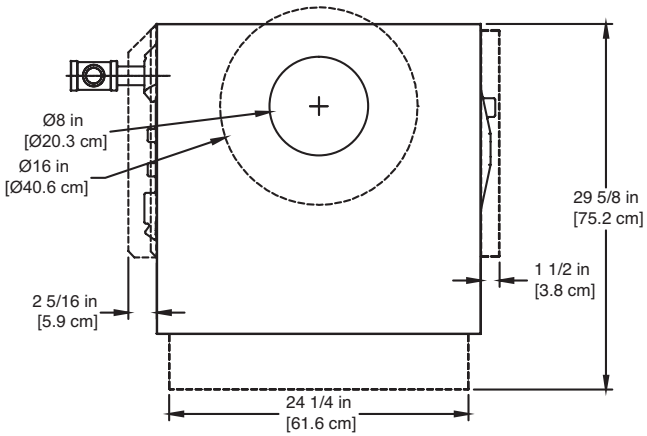

TOP

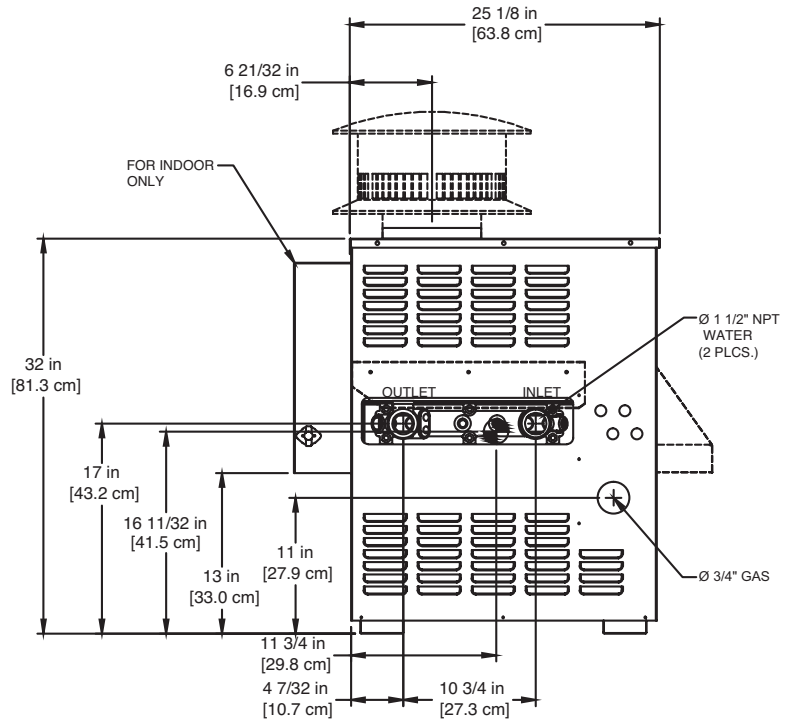

LEFT SIDE

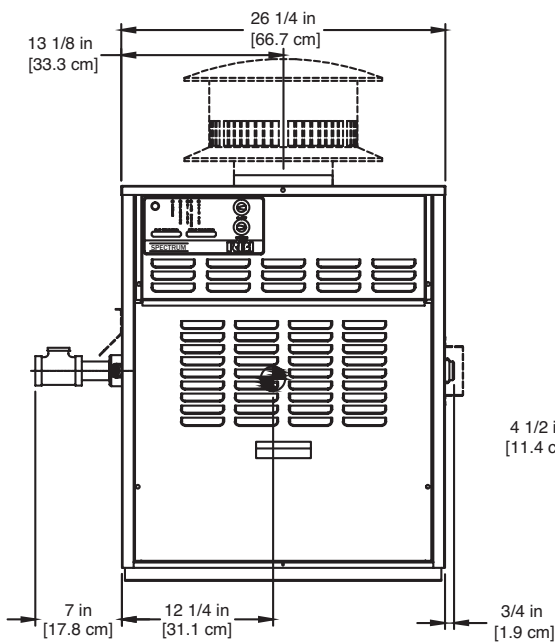

FRONT

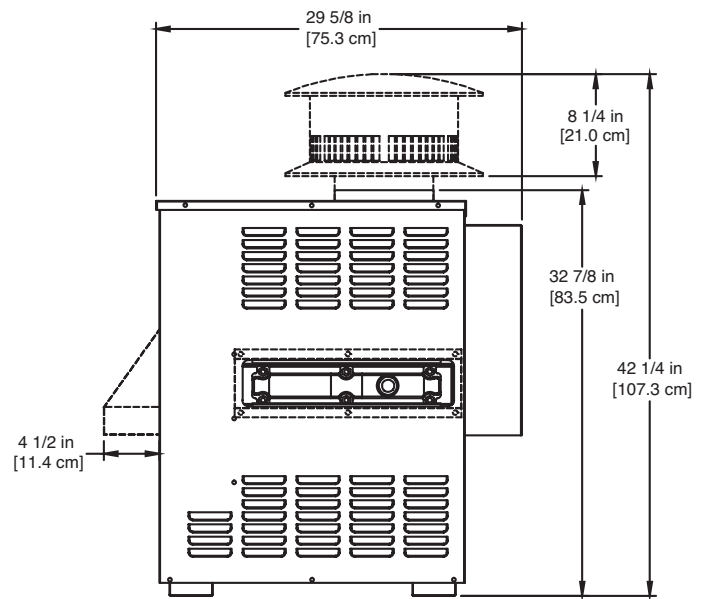

RIGHT SIDE

NOTE:  
----- FOR OUTDOOR ONLY

RSUB-4-C

### Notes:

1. Dimensions are approximate and should not be used to "rough-in" equipment.
2. Dimensions are subject to change without notice.

## BOILER CERTIFIED RATINGS & CAPACITIES

<b>Fuel Type</b>	Natural/Propane Gas	<b>Boiler FLA</b>	1*
<b>Input BTU/hr.</b>	250,000 / 73 kW	<b>Min. Gas Pressure Required</b>	5" WC**
<b>Output BTU/hr.</b>	205,000 / 60 kW	<b>Max. Gas Pressure Allowed</b>	14" WC
<b>Electrical Requirements</b>	120VAC / 1 ph / 60 hz	<b>Operating Weight</b>	218 lbs. / 99 kg.

## BOILER / WATER HEATER TRIM & CONTROLS

<b>Gas Valve - INT</b>	Honeywell VR8304M 3/4"	<b>Ignition Control (SB)</b>	Honeywell S9361A2085
<b>Gas Valve</b>	Honeywell VR8304Q 3/4" - 2 Stg.	<b>Ignition Control (SW)</b>	Honeywell S86IOM
<b>Operating Control (SB/SW)</b>	Honeywell - On/Off	<b>Relief Valve - SW</b>	3/4" x 3/4" set @ 125 psi
<b>Operating Control (SW)</b>	Jumo - 2 Stage	<b>Relief Valve - SB</b>	3/4" x 3/4" set @ 30 psi
<b>High Limit (SB/SW)</b>	Jumo	<b>Flow Switch</b>	TACO

## A.S.M.E.

<b>ASME Sect IV Htg Surface</b>	36.7 Sq. Ft. / 3.41 Sq. M.	<b>Design Data</b>	Max. 160 psig & 250°F
<b>Water Volume</b>	1.3 gal / 4.85 Liters		

\* Add circulator amps.

\*\* For incoming gas pressures lower than 5" WC natural or 11" WC propane, consult factory.

## BOILER TEMPERATURE RISE / PRESSURE DROP

10°F / 5.5°C				20°F / 11.1°C				
Flow Rate		Pressure Drop		Flow Rate		Pressure Drop		
GPM	L/s	Ft	kPa	GPM	L/s	Ft	kPa	
41.0	2.6	0.49	1.4	20.5	1.3	0.14	0.4	<b>2 Pass</b>
41.0	2.6	3.54	10.4	20.5	1.3	0.98	2.9	<b>4 Pass</b>

## WATER HEATER HOURLY RECOVERY CAPACITY (GPH & LPH)

40°F	22°C	60°F	33°C	80°F	44°C	100°F	56°C	120°F	67°C	140°F	78°C
600	2269	400	1513	300	1134	240	908	200	756	171	648

**Spectrum 250 model boiler not available for sale in the U.S. market due to DOE regulations.**

<b>REP FIRM</b>	_____
<b>SUBMITTED BY</b>	_____
<b>JOB NAME</b>	_____
<b>ARCHITECT</b>	_____
<b>ENGINEER</b>	_____
<b>CONTRACTOR</b>	_____
<b>DATE</b>	_____

# SPECTRUM 250

**Category I Appliance**

Must be vented into a negative pressure vent system.

**RBI**<sup>®</sup>  
RELIABLE. BOLD. INNOVATIVE.

A Division of Mestek, Inc.  
Westfield, MA 01085  
(413) 564-5515