

LCD 600

Category I or Category III Appliance

(see Installation and Operation Manual for venting information)

CODE OPTIONS

CSD-1

UTC Lockout/Reset Control
Manual Reset LWCO

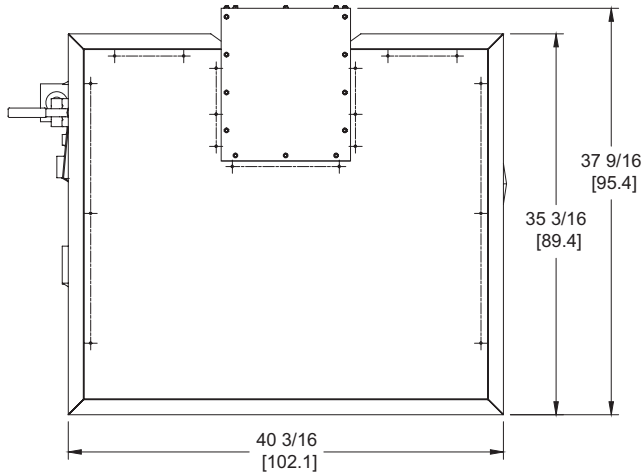

OUTDOOR TOP VIEW

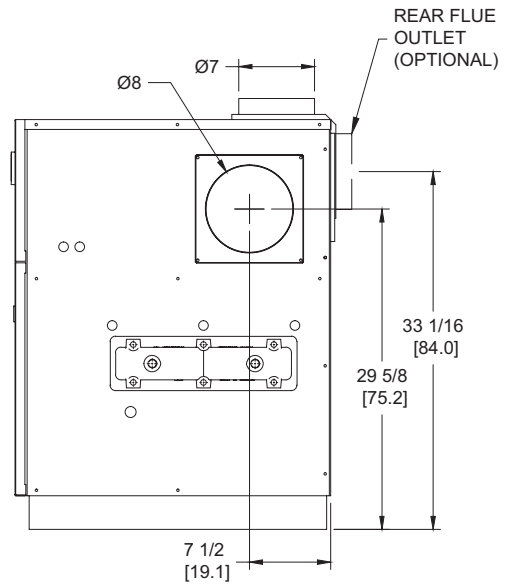

RIGHT VIEW

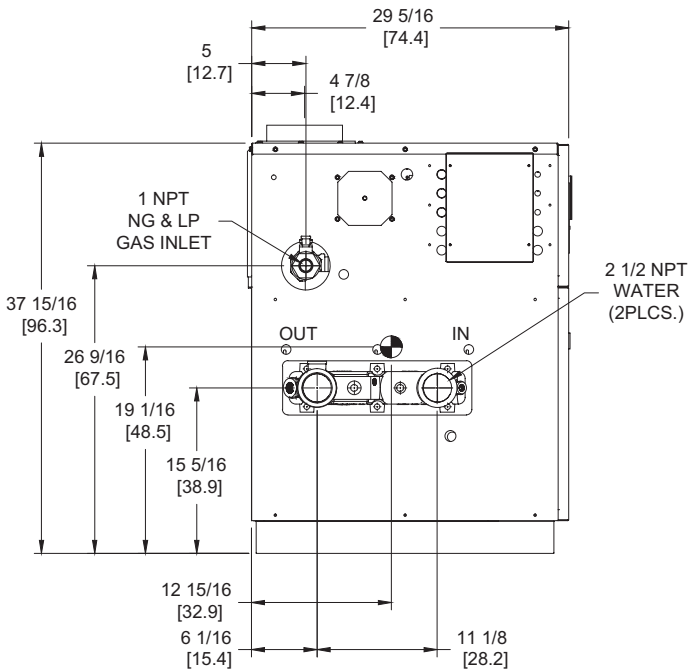

LEFT VIEW

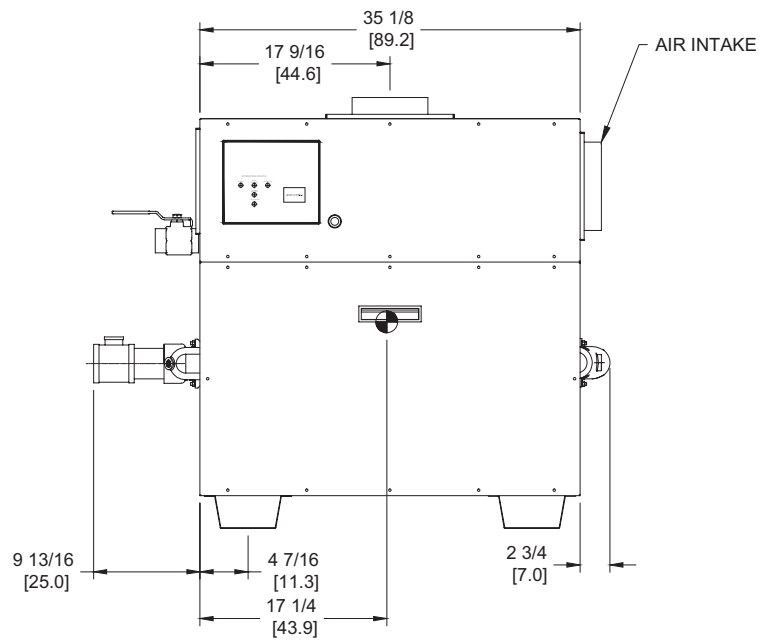

FRONT VIEW

RSUB-16-F

Notes:

1. Dimensions are approximate and should not be used to "rough-in" equipment.
2. Dimensions are subject to change without notice.
3. All dimensions are in inches (cm).
4. Symbol indicates center of gravity.

BOILER CERTIFIED RATINGS & CAPACITIES

Fuel Type	Natural/Propane Gas	Boiler FLA	3.8*
Input BTU/hr.	600,000 / 176 kW	Min. Gas Pressure Required	7" WC**
Output BTU/hr.	492,000 / 144 kW	Max. Gas Pressure Allowed	14" WC
Electrical Requirements	120VAC/ 1 ph/ 60 hz	Operating Weight	523 lbs. / 237 kg.

BOILER / WATER HEATER TRIM & CONTROLS

Main Gas Valve	Honeywell V8944B 1"	Pilot Valve	Honeywell VR8205Q
Firing Valve	Honeywell B200T1033 1"	Air Switch	Cleveland RSS-495
Safety Valve	Honeywell V48A 1"	Blower Motor	1/4 hp - FLA 3.0
Ignition Control	UTC 1003-61A	Relief Valve - LW	3/4" x 3/4" set @ 125 psi
Operating Control (LB/LW)	Jumo	Relief Valve - LB	3/4" x 3/4" set @ 50 psi
High Limit (LB/LW)	Jumo	Flow Switch	TACO

A.S.M.E.

ASME Sect IV Htg Surface	51.3 Sq. Ft. / 4.77 Sq. M.	Design Data	Max. 160 psig & 250°F
Water Volume	1.6 gal / 5.9 Liters		

* Add circulator amps.

** For incoming gas pressures lower than 7" WC natural or 11" WC propane, consult factory.

BOILER TEMPERATURE RISE / PRESSURE DROP

15°F / 8.3°C				20°F / 11.1°C				25°F / 13.9°C				30°F / 16.7°C			
Flow Rate		Pressure Drop		Flow Rate		Pressure Drop		Flow Rate		Pressure Drop		Flow Rate		Pressure Drop	
GPM	L/s	Ft	kPa	GPM	L/s	Ft	kPa	GPM	L/s	Ft	kPa	GPM	L/s	Ft	kPa
65.6	4.1	1.84	5.4	49.2	3.1	1.08	3.2	39.4	2.5	0.71	2.1	32.8	2.1	0.51	1.5

WATER HEATER HOURLY RECOVERY CAPACITY (GPH & LPH)

40°F	22°C	60°F	33°C	80°F	44°C	100°F	56°C	120°F	67°C	140°F	78°C
1477	5582	984	3721	738	2791	591	2233	492	1861	422	1595

REP FIRM _____
SUBMITTED BY _____
JOB NAME _____
ARCHITECT _____
ENGINEER _____
CONTRACTOR _____
DATE _____

LCD 600

Category I or Category III Appliance
(see Installation and Operation Manual for venting information)

RBI®
RELIABLE. BOLD. INNOVATIVE.

A Division of Mestek, Inc.
Westfield, MA 01085
(413) 564-5515