

INDOOR UNIT

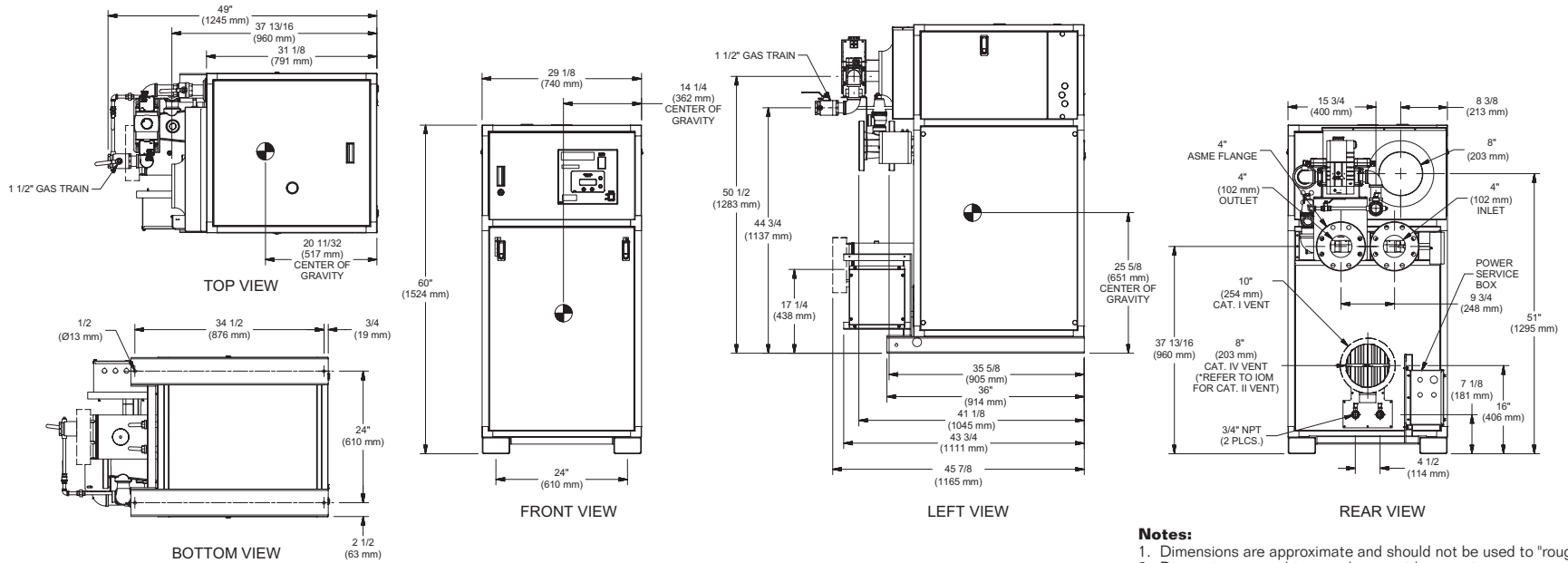

BOILER CERTIFIED RATINGS & CAPACITIES

Fuel Type	Natural/Propane Gas	Boiler FLA	10.5* @ 230V
Input BTU/hr.	3,000,000 / 879 kW	Min. Gas Pressure Required	3.5" WC**
Output BTU/hr.	2,622,000 / 768 kW	Max. Gas Pressure Allowed	14" WC
Electrical Requirements	(L1, L2, NEU, GND) 208-240 VAC/1 ph/60 Hz	Operating Weight	1,355 lbs. / 615 kgs.

BOILER TEMPERATURE RISE / PRESSURE DROP

20°F / 11.1°C				25°F / 13.9°C				30°F / 16.7°C				35°F / 19.4°C			
Flow Rate		Pressure Drop		Flow Rate		Pressure Drop		Flow Rate		Pressure Drop		Flow Rate		Pressure Drop	
GPM	L/s	Ft	kPa	GPM	L/s	Ft	kPa	GPM	L/s	Ft	kPa	GPM	L/s	Ft	kPa
262.2	16.5	15.20	44.8	209.8	13.2	9.73	28.7	174.8	11.0	6.75	19.9	149.8	9.5	4.65	13.7

BOILER / WATER HEATER TRIM & CONTROLS

Main Gas Valve Body	Dungs MBC 2500	High Limit (Manual Reset)	Jumo
Firing Valve	Honeywell B200T1066 1-1/2"	High Limit (Auto Reset)	Jumo
Main Ball Valve	1-1/2"	Blocked Flue Switch	HUBA
Manual Pilot Valve	1/4" Honeywell B528	Air Switch	HUBA
Pilot Regulator	White-Rodgers 25M	Blower Motor	American Fan 3 HP - FLA 8
Ignition Control	Honeywell RM7895C	Relief Valve - MB	1-1/4" x 1-1/2" set @ 50 psi
Operating Control	HeatNet®	Relief Valve - MW	3/4" x 3/4" set @ 125 psi
		Flow Switch	ITT FS8W

WATER HEATER HOURLY RECOVERY CAPACITY (GPH & LPH)

40°F	22°C	60°F	33°C	80°F	44°C	100°F	56°C	120°F	67°C	140°F	78°C
7590	28690	5060	19127	3795	14345	3036	11476	2530	9563	2169	8197

A.S.M.E.

ASME Sect IV Htg Surface	325.0 Sq. Ft. / 30.19 Sq. M.	Design Data	Max. 160 psig & 250°F
Water Volume	12.8 gal / 48.45 Liters		

* Add circulator amps.

** For incoming gas pressures lower than 3.5" W.C. natural or propane, consult factory.

REP FIRM _____

SUBMITTED BY _____

JOB NAME _____

ARCHITECT _____

ENGINEER _____

CONTRACTOR _____

DATE _____

FUTERA XLF 3000

Category I, II or IV Appliance
(see Installation and Operation Manual for venting information)

RBI® A Division of Mestek, Inc.
Westfield, MA 01085
(413) 568-9571

OUTDOOR UNIT

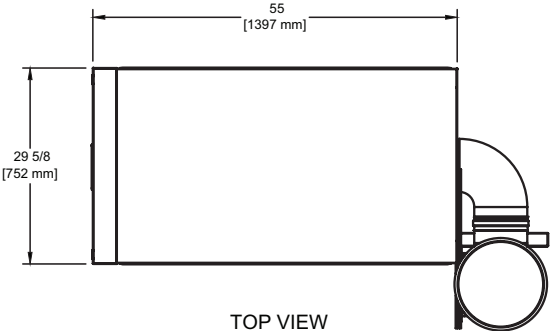

TOP VIEW

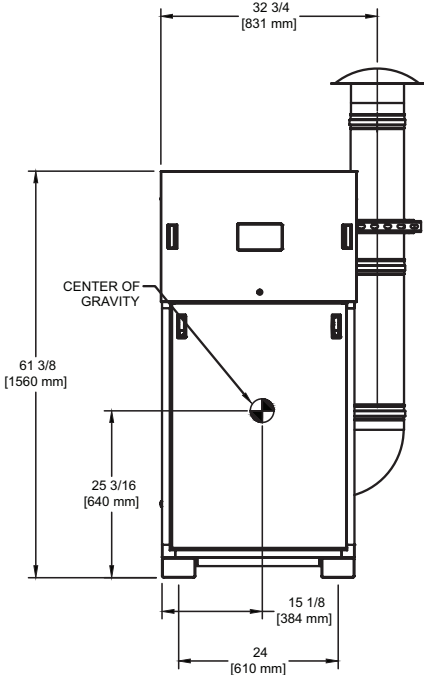

FRONT VIEW

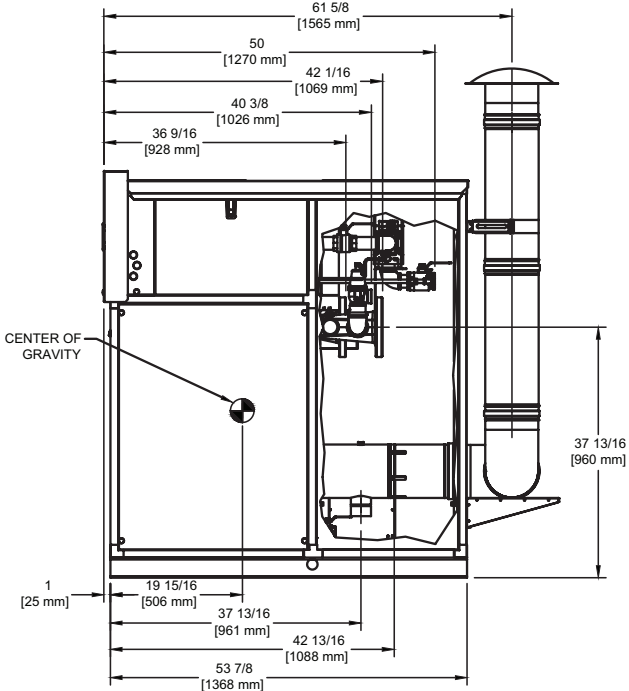

SIDE VIEW

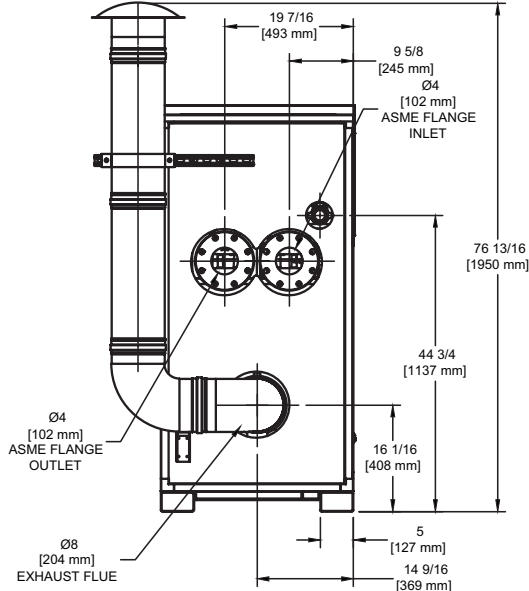

BACK VIEW

FUTERA XLF 3000

- Notes:**
1. Dimensions are approximate and should not be used to "rough-in" equipment.
 2. Dimensions are subject to change without notice.