

# AC6S35HC

**STANDARD MATERIALS AND CONSTRUCTION**

**FRAME:** .081" thk. (nominal) extruded aluminum, 6063-T52/T6 alloy.

**BLADES:** Stationary blades are .081" thk. (nominal) extruded aluminum 6063-T52/T6 alloy. Adjustable blades are .125" thk. (nominal) extruded aluminum 6063-T52/T6 alloy. Blades are approximately 4 1/2" on centers.

**LOUVER FACE:** Full width sill with head and blades contained within jambs. Concealed mullion with continuous length stationary blade.

**LINKAGE:** Extruded aluminum, concealed in the channel out of the airstream. The pivots, which rotate in Celcon bearings, are .50" dia. Zinc plated machined steel. The pivot is locked to the 5/16" dia. aluminum linkage rod by a 1/4" - 20 set screw with epoxy locking patch.

**BEARINGS:** Celcon bearing material so there will be no metal to metal scraping.

**SHAFTS:** .50" dia. aluminum "Pin-Lock" rod.

**SEALS:** Extruded silicone rubber seals at blade edge. Foam on bottom blade and polycarbonate jamb seals. Standard stainless steel at jambs required on painted louvers.

**SCREEN:** (When indicated, in a removable frame)  
 1/2" flattened aluminum, .051" thk.,  
 -or- Insect screen 1/8" aluminum mesh, .011" dia.,  
 -or- 1/2" sq. mesh intermediate double crimped aluminum wire, .063" dia.

**FINISH:** Mill.

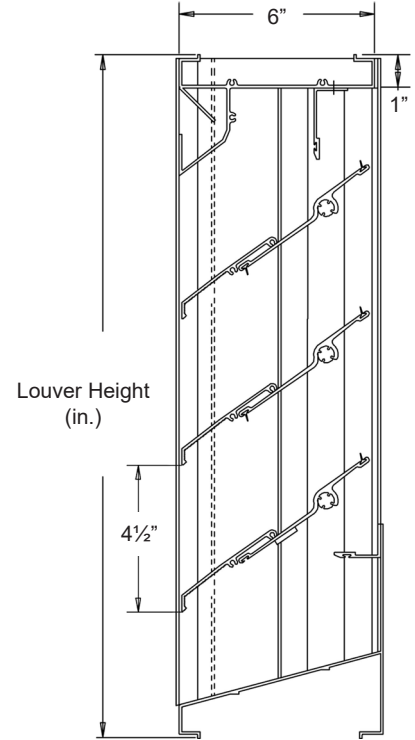

Not to scale

**OPTIONS**

Finishes - Enamels, Epoxies, etc.

Other screens available.

Actuators - Electric, Pneumatic, Manual, etc.

**NOTES**

- Nominal deductions will be made to the opening size given.
- Approximate shipping weight is 5.0 lbs./sq.ft.

**LOUVER SIZES**

Min Panel	Max Single Panel
12"W x 16"H	96"W x 72"H

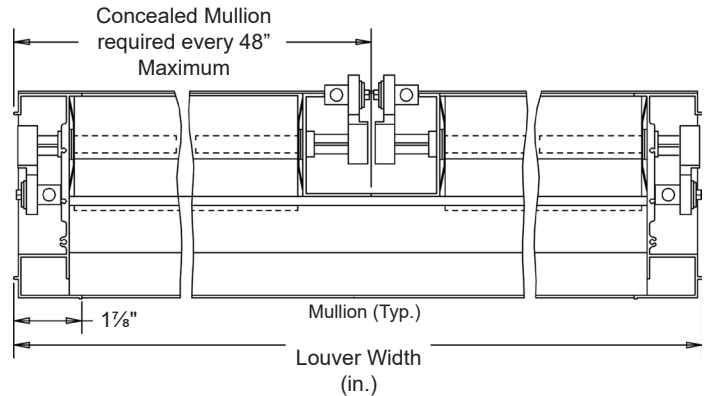
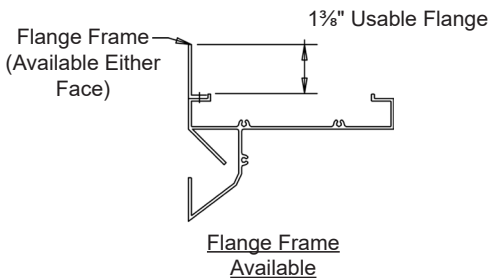

\* Visible Mullion required every 96" maximum.

In the interest of product development, Airline Louvers reserves the right to make changes without notice.

										
<b>Item #</b>	<b>Qty</b>	<b>Width</b>	<b>Height</b>	<b>Width</b>	<b>Height</b>	<b>Mullion</b>	<b>Type</b>	<b>Location</b>		
		<b>Opening Size</b>		<b>Louver Size</b>			<b>Screens</b>			<b>Union Made</b>
<b>Arch. / Eng. :</b>						<b>EDR:</b>		<b>ECN:</b>		<b>Job:</b>
<b>Contractor:</b>										
<b>Project:</b>						<b>Date:</b>		<b>DWN:</b>		<b>DWG:</b>