

ARROW

EXTRUDED ALUMINUM LOUVERS

4" DEEP

MIAMI-DADE COUNTY, FLORIDA
NOA NO. 14-0423.20 EXPIRES 7-27-18

TYPE EA-22

45° DUAL DRAIN BLADE-STATIONARY-CHANNEL TYPE
WITHSTANDS DESIGN PRESSURES UP TO 150± P.S.F.

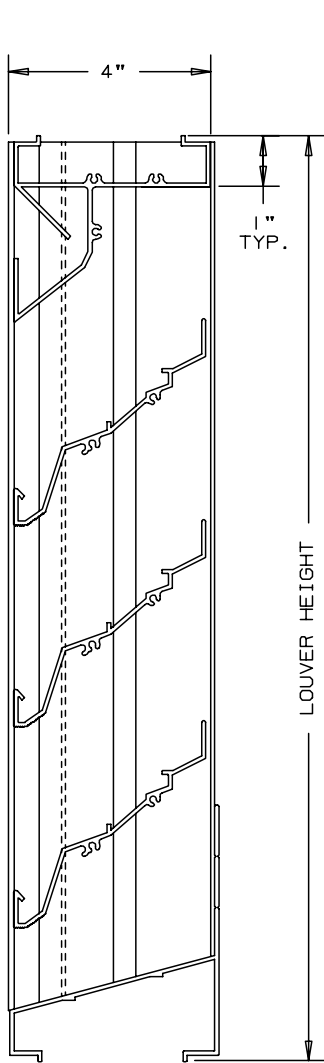

NOT TO SCALE

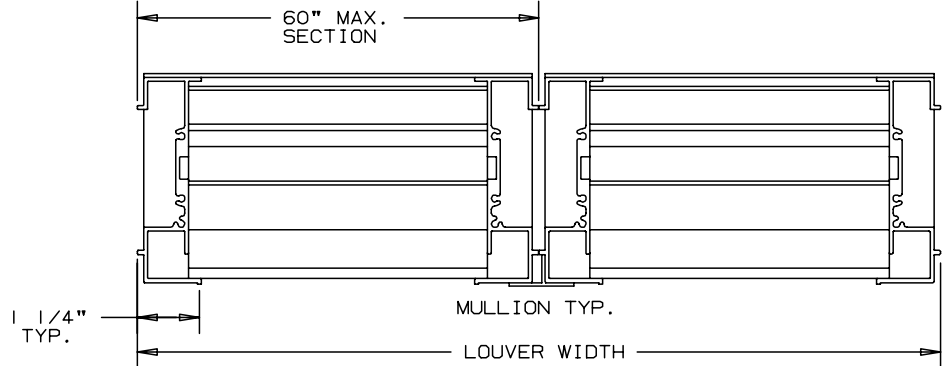

SPECIFICATIONS

MATERIAL: EXTRUDED ALUMINUM 6063-T6/T52 ALLOY
.125" THK. (NOMINAL).
FACE OF LOUVER: FULL WIDTH SILL WITH HEAD AND BLADES
CONTAINED WITHIN JAMBS. APPROXIMATE
BLADE CENTERS 4".
(WELDED CONSTRUCTION).
SCREEN: (WHEN INDICATED, IN A REMOVABLE FRAME)
BIRD SCREEN - 1/2" FLATTENED ALUMINUM, .051" THK.
OR - 1/2" SQ. MESH INTERMEDIATE DOUBLE-
CRIMPED ALUMINUM WIRE, .063" DIA.
OR - 18/16 MESH, .011" DIA. ALUMINUM
WIRE INSECT SCREEN.

FINISH: _____

MINIMUM PANEL SIZE: 12" x 12"
MAXIMUM SINGLE PANEL SIZE: 60" x 96"

LOUVER PERFORMANCE STATEMENT

PASSED MIAMI-DADE COUNTY FLORIDA TEST PROTOCOLS
PA201, PA202, AND PA203. THE ARROW LOUVER
MODEL EA-22 SHALL BE FABRICATED TO PROVIDE A
MINIMUM OF (52%), 8.37 SQUARE FEET OF FREE AREA
FOR A 48" x 48" SIZE LOUVER AND BEAR THE AMCA
CERTIFIED RATINGS PROGRAM SEAL FOR AIR PERFORMANCE
AND WATER PENETRATION. THE RATING SHALL SHOW A
BEGINNING POINT OF WATER PENETRATION AT .01 OUNCES
PER SQUARE FOOT OF FREE AREA AT A FREE AREA VELOCITY
OF 1075 FEET PER MINUTE, (8998) CUBIC FEET PER
MINUTE. WITH .15 INCHES WATER GAUGE PRESSURE DROP
FOR AIR INTAKE.

FOR CERTIFIED RATINGS
AUTHORIZED BY AMCA
-SEE REVERSE SIDE

NOMINAL DEDUCTIONS WILL BE MADE TO OPENING SIZES GIVEN.

| ITEM | QTY. | WIDTH | HEIGHT | WIDTH | HEIGHT | MULL | TYPE | LOC | | |
|------|------|--------------|--------|-------------|--------|------|------|-----|--|--|
| | | OPENING SIZE | | LOUVER SIZE | | | | | | |
| | | | | | | | | | | |



ARROW UNITED INDUSTRIES
A DIVISION OF MESTEK, INC.
450 RIVERSIDE DRIVE
WYALUSING, PA 18853
TEL: (570) 746-1888 FAX: (570) 746-9286
WEB ADDRESS: WWW.ARROWUNITED.COM

AGENT: _____

| |
|-------------------|
| ARCH./ENG. : |
| CONTR. : |
| PROJECT : |
| EDR: ECN: JOB: |
| DATE: DWN.: DWG.: |

LOUVER MODEL EA-22

45° DRAIN BLADE

EXTRUDED ALUMINUM - STATIONARY

PERFORMANCE DATA

EXCELLENT WEATHER PROTECTION WITH LITTLE PRESSURE LOSS.

TESTS OF A 48" X 48" SAMPLE ACCORDING TO AMCA STANDARD 500-L SHOWS LOW WATER PENETRATION. TESTS SHOW LESS THAN .02 OZ. PER SQ. FT. WATER PENETRATION AT 1100 FPM (FREE AREA VELOCITY) WITH LESS THAN .17 W.G. PRESSURE DROP (INTAKE).

RATINGS DO NOT INCLUDE THE EFFECT OF BIRDSCREEN.

PRESSURE DROP

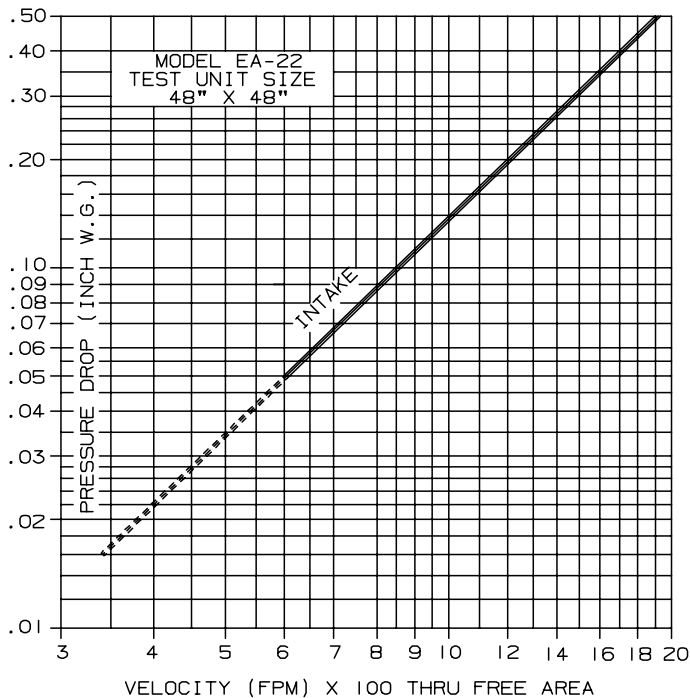

WATER PENETRATION

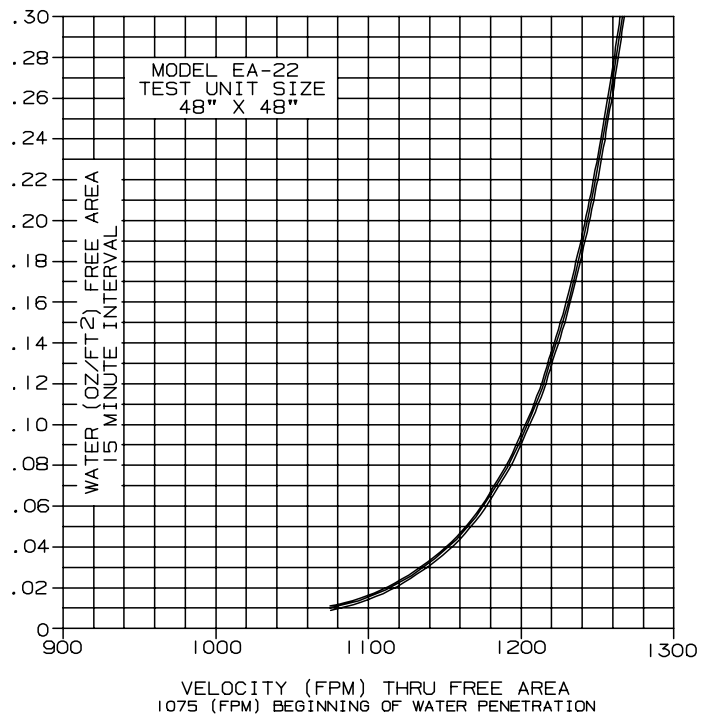

FREE AREA

| HEIGHT | FREE AREA (SQ. FT.) | | | | | | | | |
|--------|---------------------|------|------|-------|-------|-------|-------|-------|-------|
| | WIDTH | | | | | | | | |
| | 12" | 18" | 24" | 30" | 36" | 42" | 48" | 54" | 60" |
| 12" | .31 | .50 | .70 | .90 | 1.09 | 1.29 | 1.48 | 1.68 | 1.87 |
| 24" | .81 | 1.31 | 1.82 | 2.33 | 2.84 | 3.35 | 3.86 | 4.36 | 4.87 |
| 36" | 1.30 | 2.12 | 2.94 | 3.77 | 4.59 | 5.41 | 6.23 | 7.05 | 7.87 |
| 48" | 1.80 | 2.93 | 4.07 | 5.20 | 6.34 | 7.47 | 8.37 | 9.74 | 10.87 |
| 60" | 2.29 | 3.74 | 5.19 | 6.64 | 8.08 | 9.53 | 10.98 | 12.43 | 13.88 |
| 72" | 2.79 | 4.55 | 6.31 | 8.07 | 9.83 | 11.59 | 13.35 | 15.12 | 16.88 |
| 84" | 3.28 | 5.36 | 7.43 | 9.51 | 11.58 | 13.65 | 15.73 | 17.80 | 19.88 |
| 96" | 3.78 | 6.17 | 8.55 | 10.94 | 13.33 | 15.72 | 18.10 | 20.49 | 22.88 |

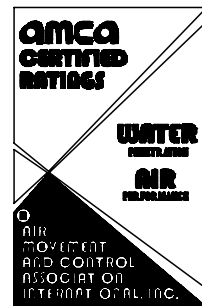

ARROW UNITED CERTIFIES THAT THE MODEL EA-22 LOUVERS SHOWN HEREIN IS LICENSED TO BEAR THE AMCA SEAL. THE RATINGS SHOWN ARE BASED ON TESTS AND PROCEDURES PERFORMED IN ACCORDANCE WITH THE AMCA PUBLICATION 511 AND COMPLY WITH THE REQUIREMENTS OF THE AMCA CERTIFIED RATINGS PROGRAM. THE CERTIFIED RATINGS SEAL APPLIES TO AIR PERFORMANCE RATINGS AND WATER PENETRATION RATINGS.

ARROW HURRICANE LOUVER INSTALLATION DETAILS

MODEL EA-22

MIAMI- DADE COUNTY, FLORIDA
NOA NO. 14-0423.20 EXPIRES 7-27-18

HEAD/SILL DETAIL

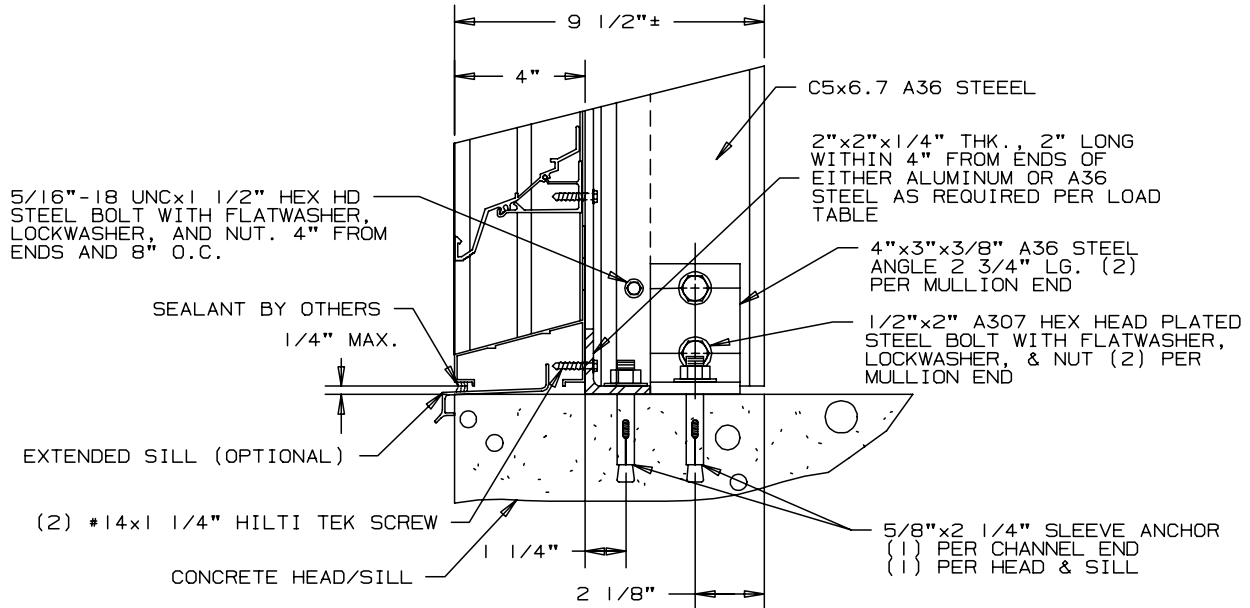

JAMB DETAIL

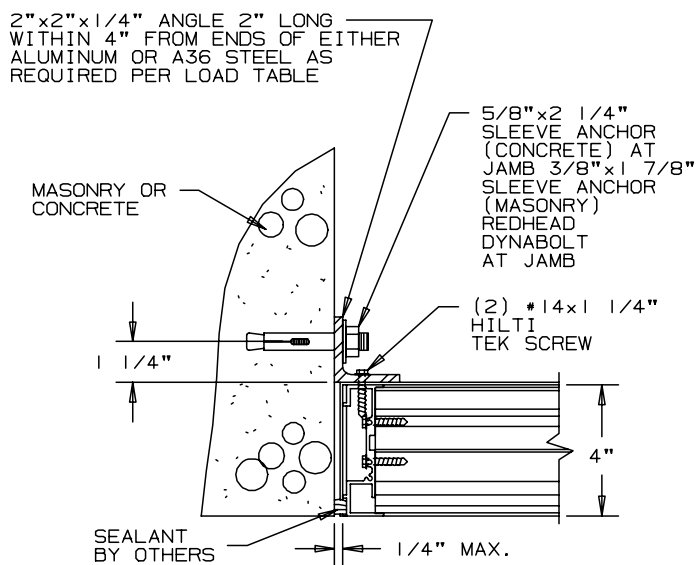

VISIBLE VERTICAL MULLION DETAIL

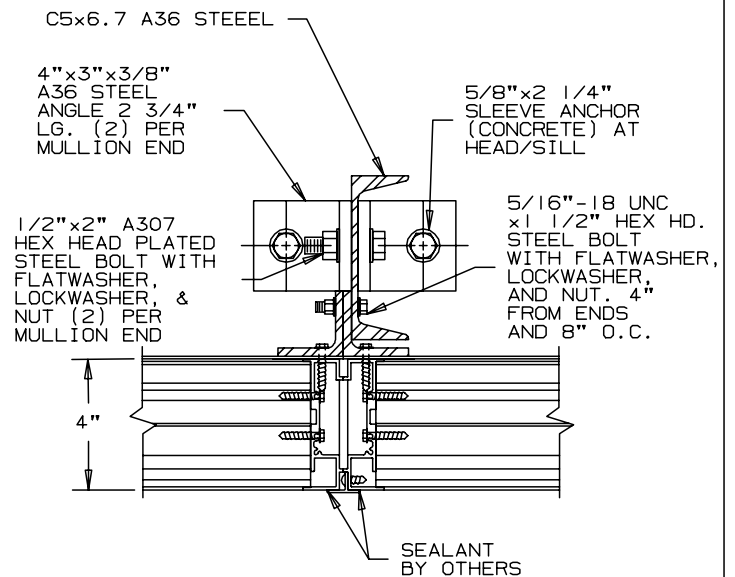

NOTE: INSTALLATION SHOWN IS FOR CONCRETE/MASONRY