

**APPLICATION**

The X-Style Sleeve is an integral sleeve frame. The sleeve length comes in 2 depths, 12" and 14". The integral sleeve frame comes in three different styles. The "A" style is without any transition, and the blades are in the air stream (see also SD-17S, SD-38S, SD-17D, SD-38D). The "B" style has a B-Pan so the blades are out of the airstream (see also SI-BPAN). The "C" style is with a round, oval, or square transition and has 100% Free Area (see also SI-TRFD).

**PANEL SIZE LIMITATIONS**

Orientation		Horizontal & Vertical	Horizontal	Vertical	
Panel		Minimum Panel	Maximum Section	Maximum Section	
Model	17SX	A	4"W x 4"H	48"W x 48"H	60"W x 60"H
		B	4"W x 3"H duct (4"W x 5"H frame)	48"W x 43"H duct (48"W x 48"H frame)	60"W x 55"H duct (60"W x 60"H frame)
		C	4"W x 4"H duct (6"W x 7"H frame)	46"W x 42"H duct (48"W x 48"H frame)	58"W x 54"H duct (60"W x 60"H frame)
	38SX	A	4"W x 4"H	48"W x 48"H	36"W x 36"H
		B	4"W x 3"H duct (4"W x 5"H frame)	48"W x 43"H duct (48"W x 48"H frame)	36"W x 32"H duct (36"W x 36"H frame)
		C	4"W x 4"H duct (6"W x 7"H frame)	46"W x 42"H duct (48"W x 48"H frame)	34"W x 31"H duct (36"W x 36"H frame)
	17DX	A	4"W x 4"H	24"W x 24"H	36"W x 36"H
		B	4"W x 3"H duct (4"W x 5"H frame)	24"W x 21"H duct (24"W x 24"H frame)	36"W x 32"H duct (36"W x 36"H frame)
		C	4"W x 4"H duct (6"W x 7"H frame)	22"W x 20"H duct (24"W x 24"H frame)	34"W x 31"H duct (36"W x 36"H frame)
	38DX	A	4"W x 4"H	24"W x 24"H	36"W x 36"H
		B	4"W x 3"H duct (4"W x 5"H frame)	24"W x 21"H duct (24"W x 24"H frame)	36"W x 32"H duct (36"W x 36"H frame)
		C	4"W x 4"H duct (6"W x 7"H frame)	22"W x 20"H duct (24"W x 24"H frame)	34"W x 31"H duct (36"W x 36"H frame)

**STANDARD CONSTRUCTION**

**SLEEVE FRAME:** 22 GA. one-piece roll-formed galvanized steel.

**BLADE:** 22 GA. galvanized steel, curtain type.

**FUSIBLE LINK:** UL-Listed 165°F, replaceable.

**CLOSURE SPRINGS:** For all Dynamic and Horizontal Static Models  
Heat-treated Type 301 stainless steel constant force coiled negator type.

**FINISH:** Mill.

**FOR "C" STYLE DAMPERS**

**TRANSITION CAPS:** 20 GA. galvanized steel, riveted to sleeve frame.

**DUCT COLLARS:** 24 GA. galvanized steel, crimped to transitions.

**OPTIONS**

212°F replaceable fusible link

PK1202 position indicator switch

B-Pan, round, oval, or square transitions

Tab-lock retaining angles

Perimeter flange

Pull ring

**NOTES**

1. Nominal deductions will be made to the opening size given.

# X-Style Sleeve

Galvanized Steel Fire Damper • 17S, 38S, 17D, 38D

## "A" Style

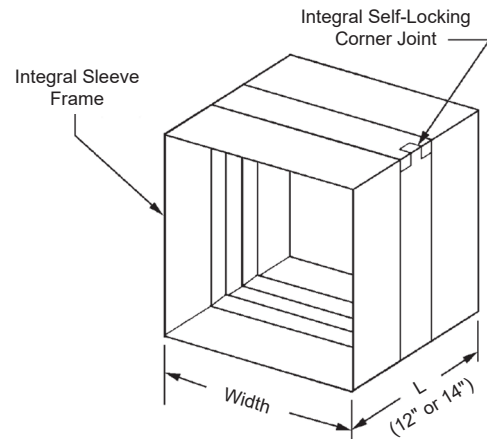
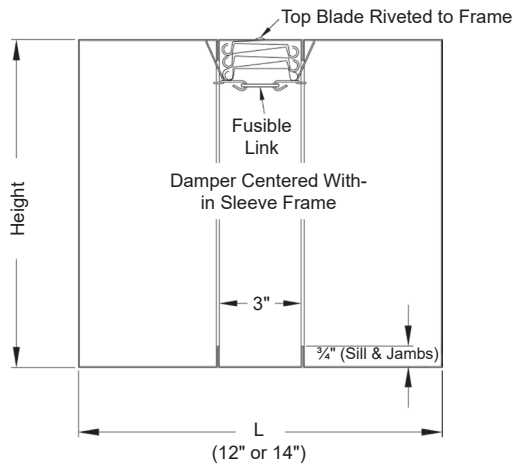

## "B" Style (with B-Pan Transition for Blades Out of Airstream)

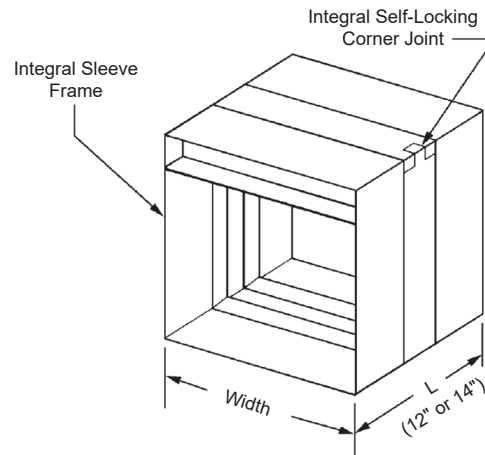
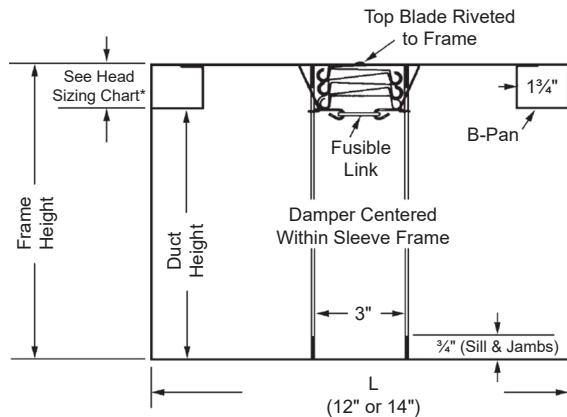

\*Head Sizing Chart on SI-BPAN.

## "C" Style (with Transition for 100% Free Area)

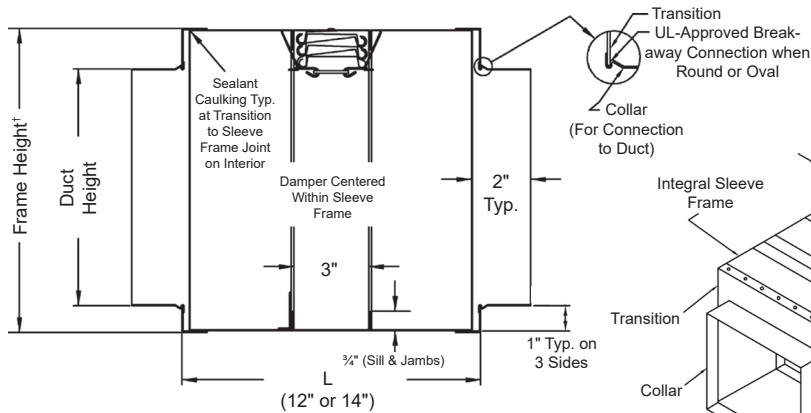

\*Sizing Chart on SI-TRFD.

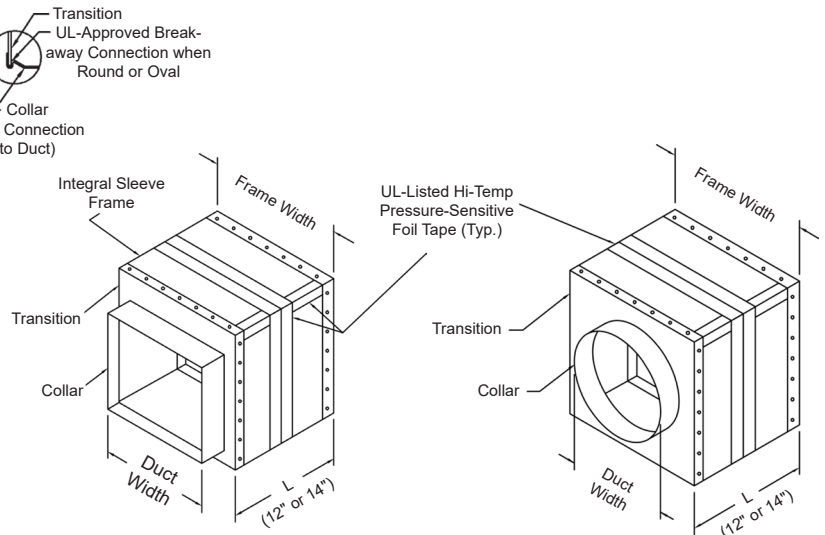

# X-Style Sleeve

## Galvanized Steel Fire Damper • 17S, 38S, 17D, 38D

### APPLICATION

The X-Style Sleeve is an integral sleeve frame. The sleeve length comes in 2 depths, 12" and 14". The integral sleeve frame comes in three different styles. The "A" style is without any transition, and the blades are in the air stream (see also SD-17S, SD-38S, SD-17D, SD-38D). The "B" style has a B-Pan so the blades are out of the airstream (see also SI-BPAN). The "C" style is with a round, oval, or square transition and has 100% Free Area (see also SI-TRFD).

### PANEL SIZE LIMITATIONS

Orientation		Horizontal & Vertical	Horizontal	Vertical	
Panel		Minimum Panel	Maximum Section	Maximum Section	
Model	17SX	A	4"W x 4"H	48"W x 48"H	60"W x 60"H
		B	4"W x 3"H duct (4"W x 5"H frame)	48"W x 43"H duct (48"W x 48"H frame)	60"W x 55"H duct (60"W x 60"H frame)
		C	4"W x 4"H duct (6"W x 7"H frame)	46"W x 42"H duct (48"W x 48"H frame)	58"W x 54"H duct (60"W x 60"H frame)
	38SX	A	4"W x 4"H	48"W x 48"H	36"W x 36"H
		B	4"W x 3"H duct (4"W x 5"H frame)	48"W x 43"H duct (48"W x 48"H frame)	36"W x 32"H duct (36"W x 36"H frame)
		C	4"W x 4"H duct (6"W x 7"H frame)	46"W x 42"H duct (48"W x 48"H frame)	34"W x 31"H duct (36"W x 36"H frame)
	17DX	A	4"W x 4"H	24"W x 24"H	36"W x 36"H
		B	4"W x 3"H duct (4"W x 5"H frame)	24"W x 21"H duct (24"W x 24"H frame)	36"W x 32"H duct (36"W x 36"H frame)
		C	4"W x 4"H duct (6"W x 7"H frame)	22"W x 20"H duct (24"W x 24"H frame)	34"W x 31"H duct (36"W x 36"H frame)
	38DX	A	4"W x 4"H	24"W x 24"H	36"W x 36"H
		B	4"W x 3"H duct (4"W x 5"H frame)	24"W x 21"H duct (24"W x 24"H frame)	36"W x 32"H duct (36"W x 36"H frame)
		C	4"W x 4"H duct (6"W x 7"H frame)	22"W x 20"H duct (24"W x 24"H frame)	34"W x 31"H duct (36"W x 36"H frame)

### STANDARD CONSTRUCTION

**SLEEVE FRAME:** 22 GA. one-piece roll-formed galvanized steel.

**BLADE:** 22 GA. galvanized steel, curtain type.

**FUSIBLE LINK:** UL-Listed 165°F, replaceable.

**CLOSURE SPRINGS:** For all Dynamic and Horizontal Static Models  
Heat-treated Type 301 stainless steel constant force coiled negator type.

**FINISH:** Mill.

#### FOR "C" STYLE DAMPERS

**TRANSITION CAPS:** 20 GA. galvanized steel, riveted to sleeve frame.

**DUCT COLLARS:** 24 GA. galvanized steel, crimped to transitions.

### OPTIONS

212°F replaceable fusible link  
PK1202 position indicator switch  
B-Pan, round, oval, or square transitions  
Tab-lock retaining angles  
Perimeter flange  
Pull ring

### NOTES

1. Nominal deductions will be made to the opening size given.

# X-Style Sleeve

Galvanized Steel Fire Damper • 17S, 38S, 17D, 38D

## “A” Style

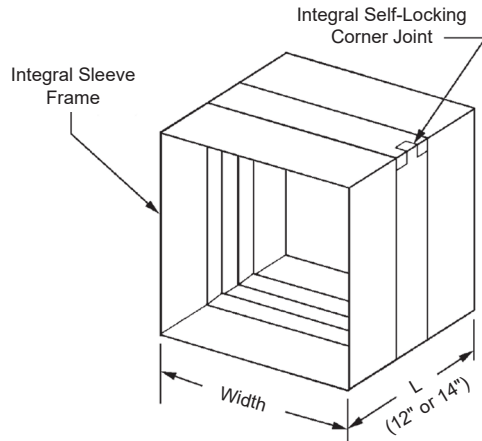
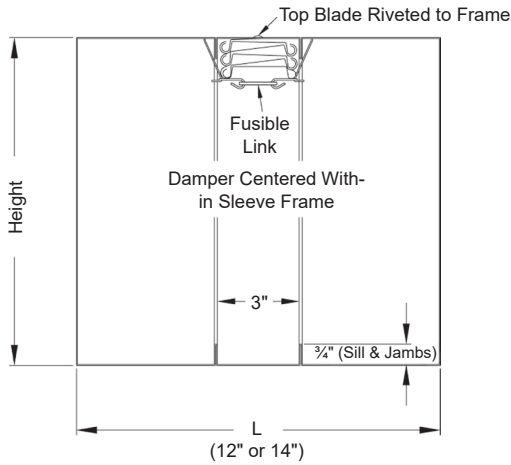

## “B” Style (with B-Pan Transition for Blades Out of Airstream)

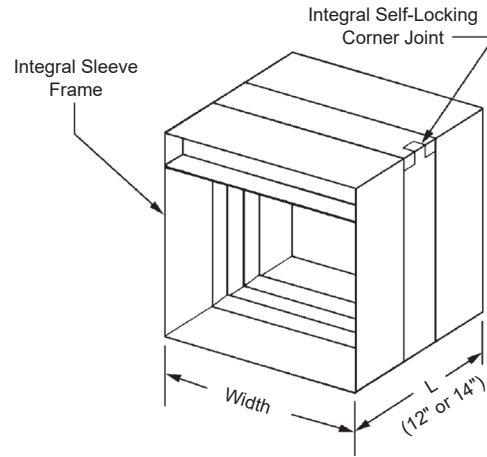
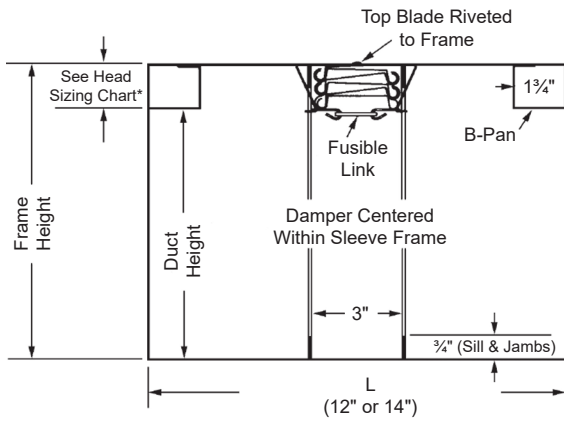

\*Head Sizing Chart on SI-BPAN.

## “C” Style (with Transition for 100% Free Area)

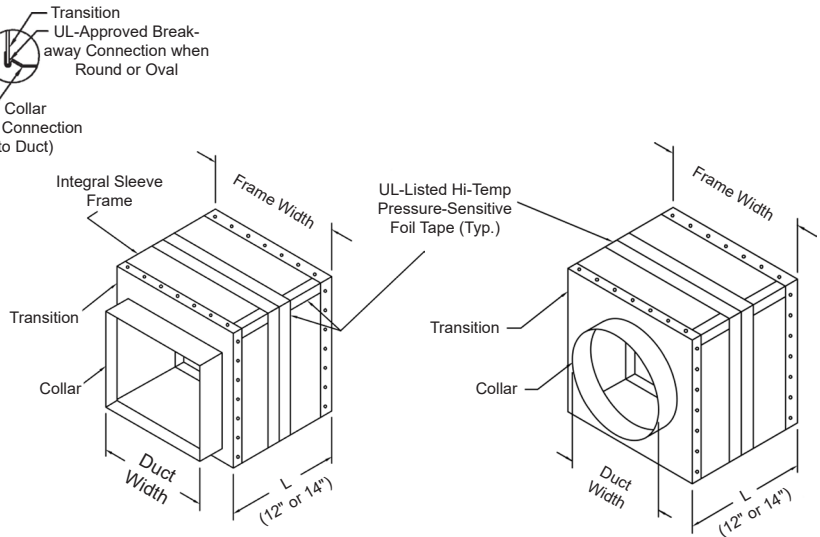
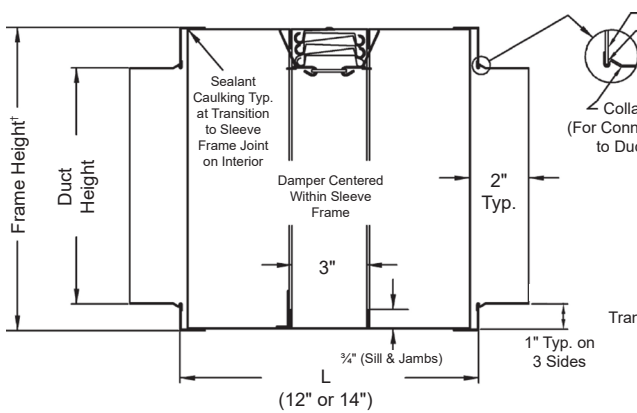

\*Sizing Chart on SI-TRFD.