

Damper Operation Test Box

For all MCDLG Combination Fire-Smoke and Smoke Damper Models

APPLICATION

Per NFPA 80 and 105, "Each damper shall be tested and inspected one year after installation. The test and inspection frequency shall be every 4 years, except in hospitals, where the frequency shall be every 6 years."

Prior to the inception of these remote damper operation testing features, our fire-smoke dampers could be cycled by manually tripping the heat response device or by pressing the test button on the smoke detector. These methods required that you disconnected power and remove access panels to reset the heat response device or that you gain access to the smoke detector interface, which is quite often not in an easily accessible location once the damper is installed.

Our optional remote operation testing features enable you to cycle test the damper via a remote test station, which can be ordered in a variety of configurations to fit your application. Although visual inspection and maintenance are still required, position indicator switches can be incorporated into these testing features to enable remote monitoring of blade location.

NOTE: One remote test box is required for each MASTER actuator. Refer to SI-ACTLOC for additional details on master actuators.

Momentary Push Button Test Box

The Momentary Push Button Test Box will permit momentary interruption of power to the fire-smoke or smoke damper. As long as the spring-loaded toggle is depressed, power is disconnected and the damper will travel to its fail position. A position indication package is not required with this feature.

Factory Mounted

Shipped Loose

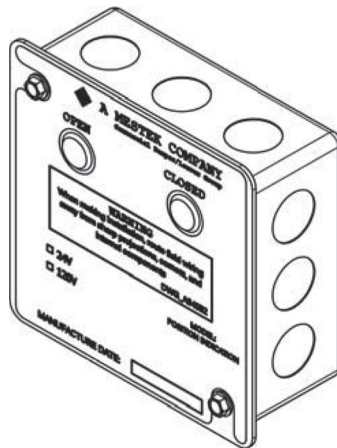
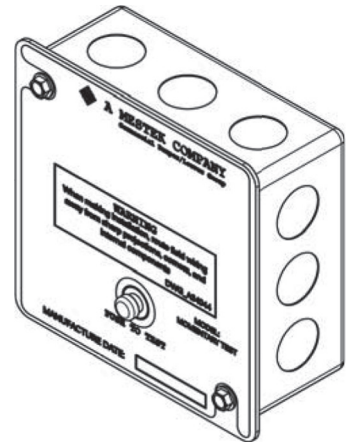

Lights Only Position Indication Test Box

The Lights Only Test Box will permit remote open and closed blade position indication of the fire-smoke or smoke damper. A position indication package **is required** with this feature.

Factory Mounted

Shipped Loose

24 VAC/DC

120 VAC

Test Boxes with Position Indication

Test Boxes with position indication will permit interruption of power to the fire-smoke or smoke damper and permit remote open and close blade position indication. As long as the momentary switch is depressed or toggle switch is toggled to the "power off" position (toggle switches are not spring-return type), power is disconnected and the damper will travel to its fail position. When the damper reaches its full open position a green LED will illuminate, when the damper reaches its full closed positional red/amber LED will illuminate. A position indication package is required with these features.

Factory Mounted

Shipped Loose

24 VAC/DC

120 VAC

2-Position Push-Button Momentary

2-Position Momentary Toggle (Shown)

3-Position Toggle (Only available w/ ESOT or PSOT)

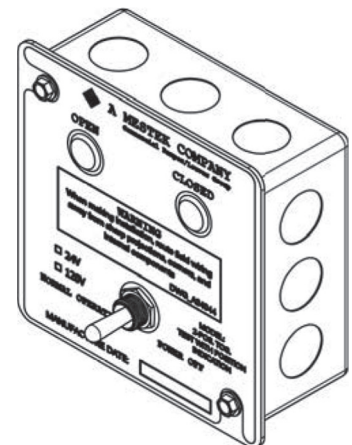

Damper Operation Test Box

For all MCDLG Combination Fire-Smoke and Smoke Damper Models

DESCRIPTION

The Test Box consists of a 4" wide x 4" high x 2¼" deep steel box with multiple conduit knockouts. The steel cover is mounted and labeled for the appropriate configuration that has been selected.

FACTORY MOUNTED VS. SHIP LOOSE

Factory mounted test boxes will ship with the 4" x 4" test box connected and wired to the master actuator with a 3' x ½" flexible galvanized conduit whip (or whips, if necessary). Although the box is pre-wired and complete with conduit and fittings, the test box itself will not be secured to the damper such that the installer can fasten the box in the location best suited to each installation. Consult the factory if your application requires a whip that is longer than 3'. The voltage of the test box will match the voltage of the actuator that is selected with the damper.

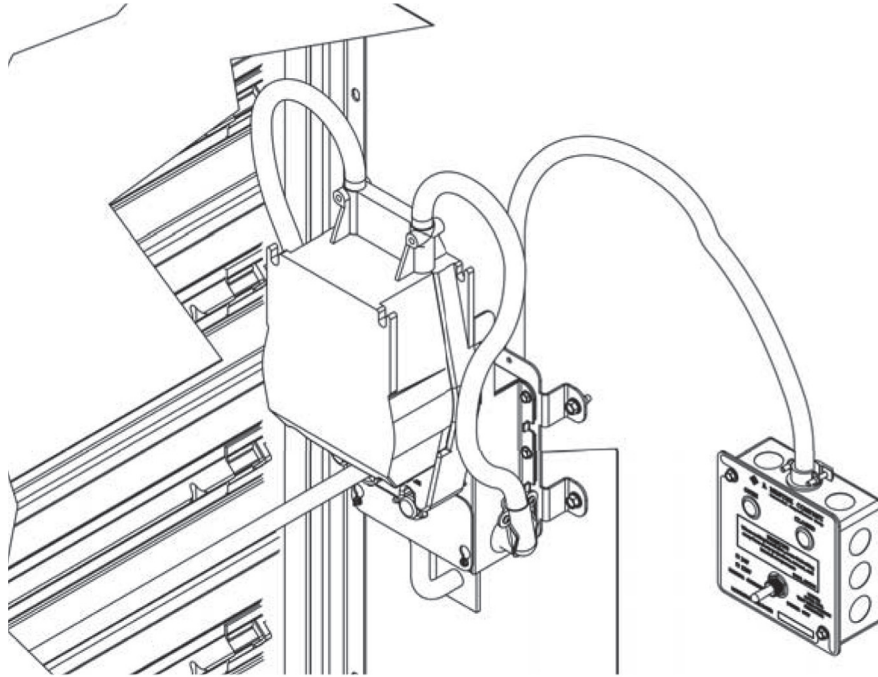

Ship loose test boxes will only ship with the 4" x 4" test box assembled with the applicable combination of a switch and/or lights mounted on a cover plate. All additional wires, conduit, fittings, and hardware are by others. When ordering ship loose, you must specify the required voltage (24 V or 120 V). The following schematic represent factory wiring scenarios, field conditions may require variations of these suggested circuits.

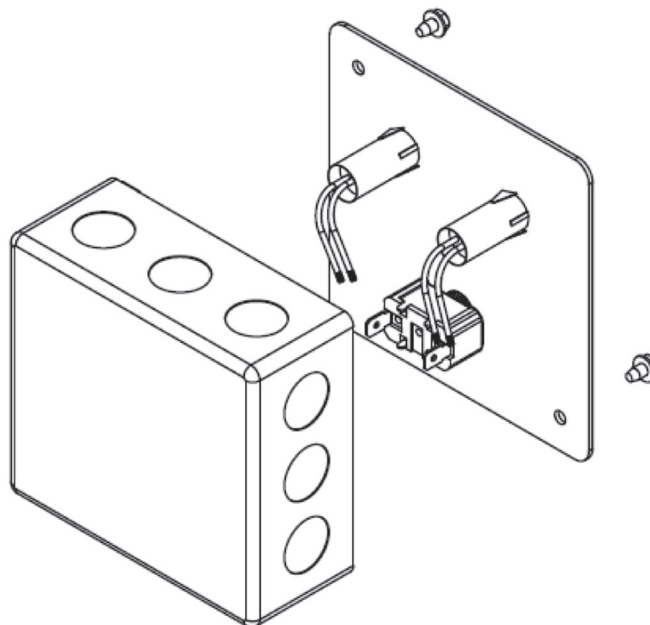

Damper Operation Test Box

For all MCDLG Combination Fire-Smoke and Smoke Damper Models

SCHEMATICS

Factory wiring for 2-position Momentary Test

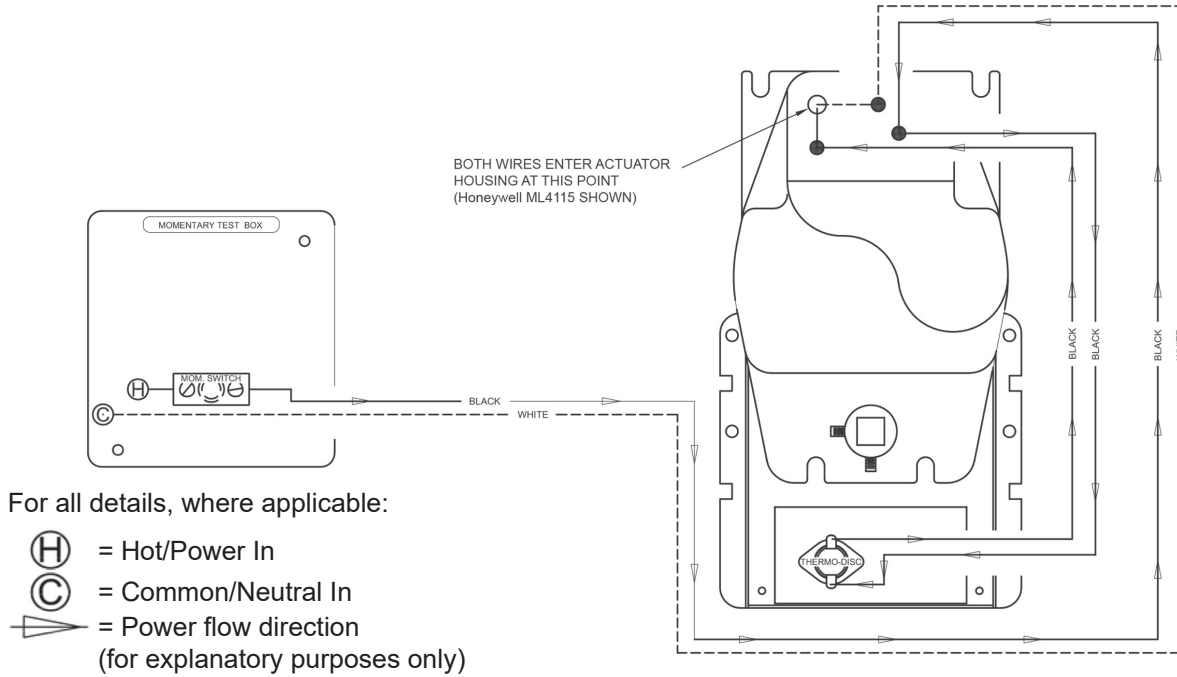

NOTE: Thermo-disc is not part of a smoke damper circuit.

Factory wiring for 2-position Momentary (Or Toggle) Test with Position Indication

Shown with auxiliary switch package; damper in closed position with red/amber LED illuminated.

See page 4, Wiring Chart for additional switch package wiring details.

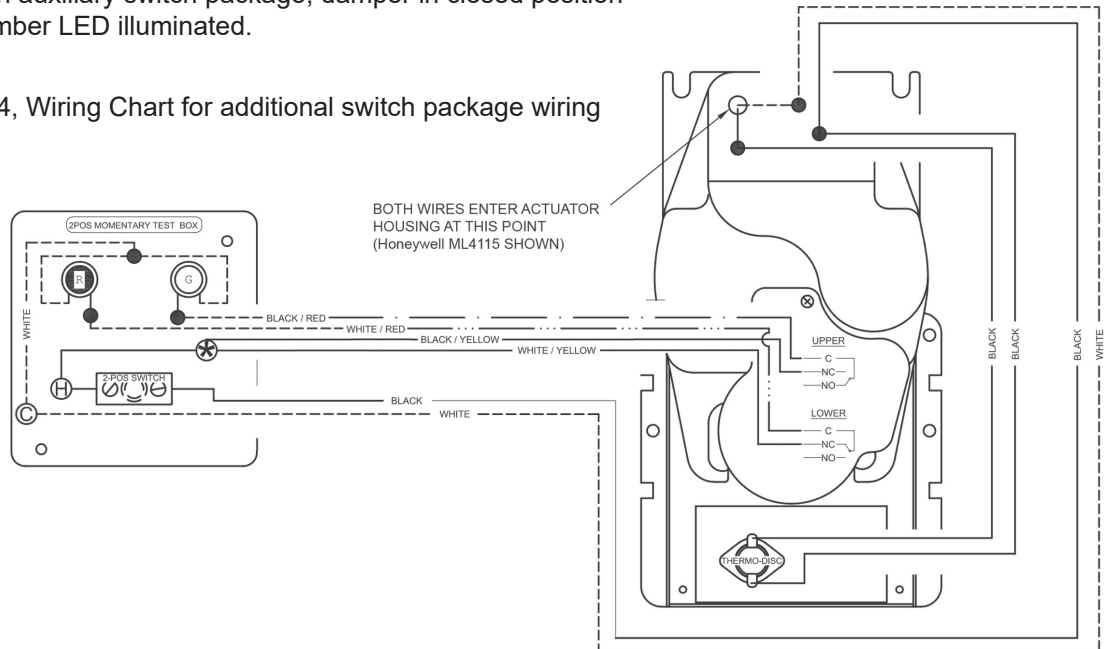

NOTE: For ship loose installations where indicator LED voltage is to be different than the actuator's voltage, remove jumper wire between [H] and [*] between common/white wires, connect indicator voltage at [*], and connect actuator voltage at [H], and applicable common to common.

Damper Operation Test Box

For all MCDLG Combination Fire-Smoke and Smoke Damper Models

Factory wiring for 3-position Toggle Test with Position Indication

(Used only on fire-smoke dampers with ESOT)

NOTE: It is intended that an additional power lead be connected to the orange 're-open' lead such that remote opening of the damper can happen from location other than this remote test box, such as a fire control or building management system.

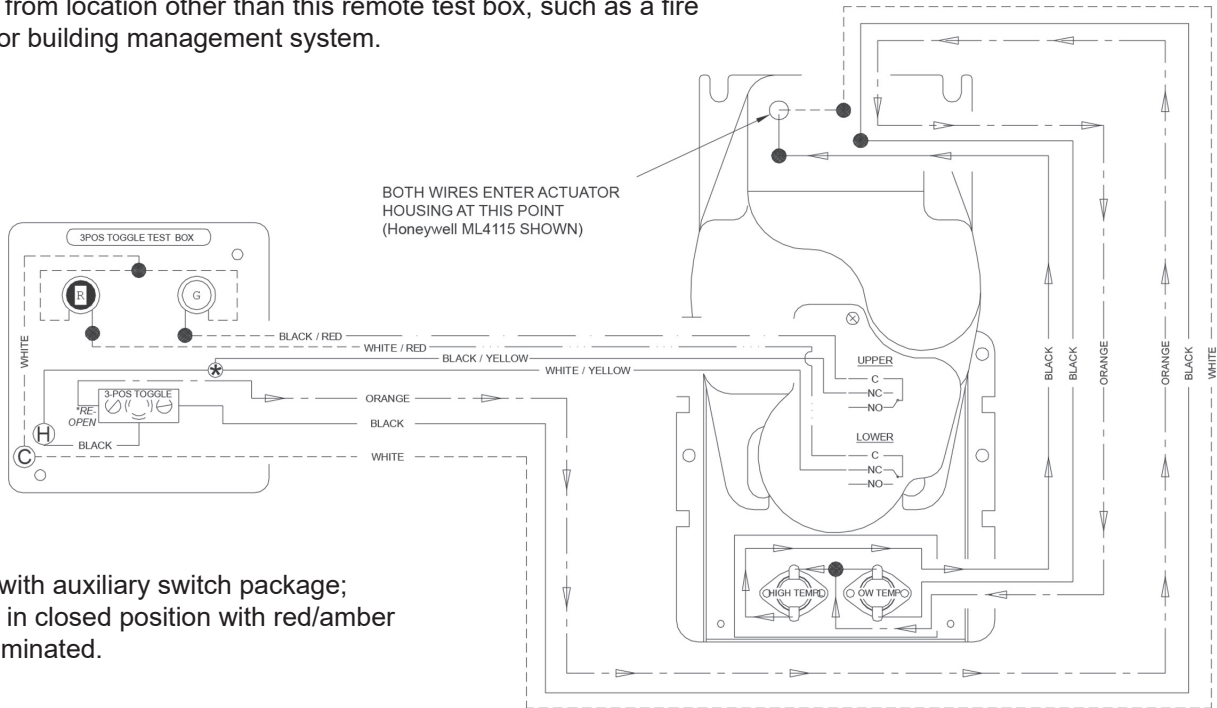

Shown with auxiliary switch package; damper in closed position with red/amber LED illuminated.

NOTE: For ship loose installations where indicator LED voltage is to be different than the actuator's voltage, remove jumper wire between [H] and [*] between common/white wires, connect indicator voltage at [*], and connect actuator voltage at [H], and applicable common to common.

For all details, where applicable:

- (H)** = Hot/Power In
- (C)** = Common/Neutral In
- ▶** = Power flow direction (for explanatory purposes only)

	Closed Damper Indication		Open Damper Indication	
	Lower Limit Condition	Normally Closed (Lower)	Upper Limit Common	Normally Closed (Upper)
PK 1200 - 1201 Package	Red	Blue	Gray	Orange
Belimo FSLF	S1	S2	S4	S6
Belimo FSNF	S1	S2	S4	S5
Belimo FSAFB24-SR-S	S1	S2	S4	S5
Honeywell Auxiliary	White / Red	White / Yellow	Black / Red	Black / Yellow
Honeywell 4104F / 4120 Series	Blue	Blue	Yellow	Yellow

Damper Operation Test Box

For all MCDLG Combination Fire-Smoke and Smoke Damper Models

Factory wiring for 2-position Momentary or Toggle Test with Position Indicator and Smoke Detector

See page 4, Wiring Chart for additional switch package wiring details.

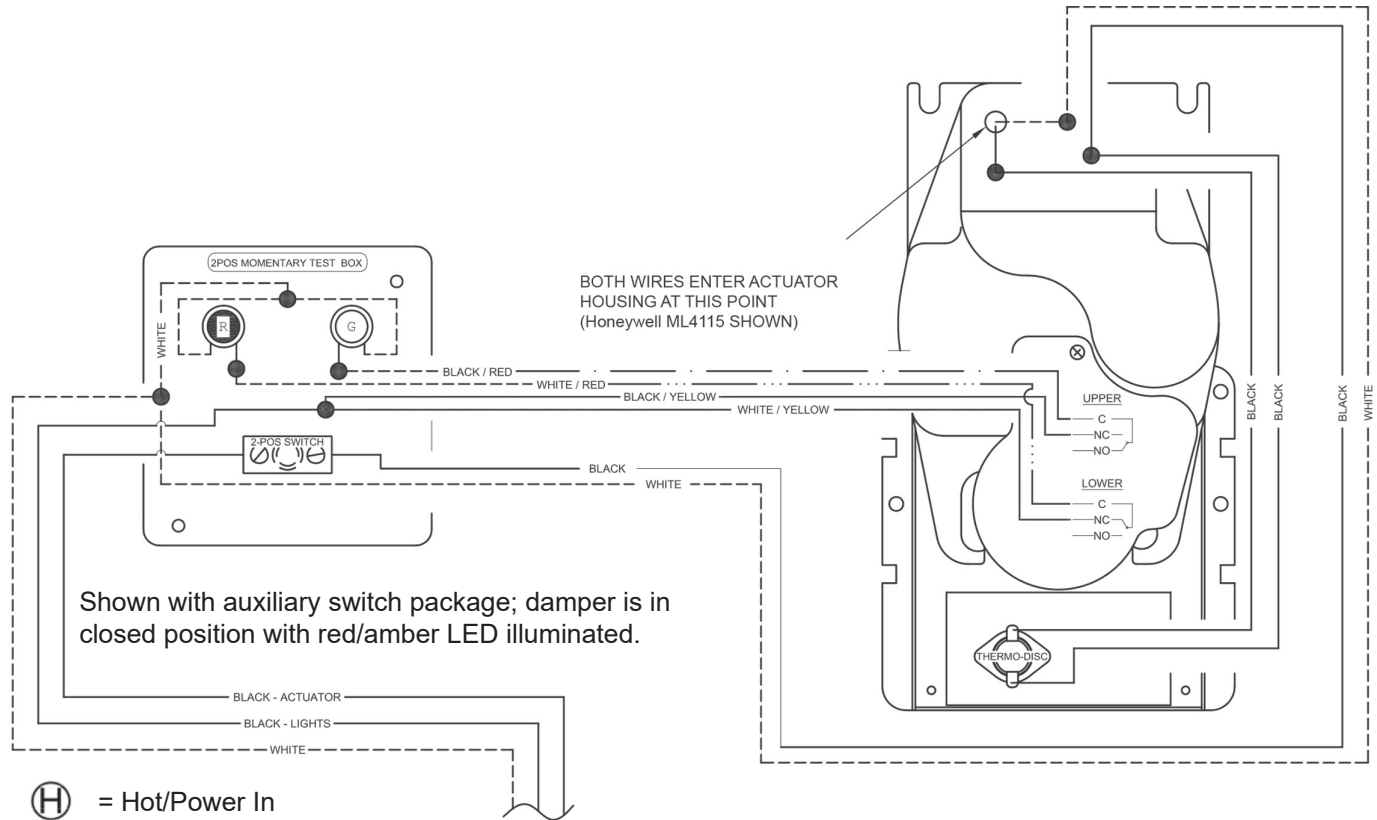

- (H)** = Hot/Power In
- (C)** = Common/Neutral In

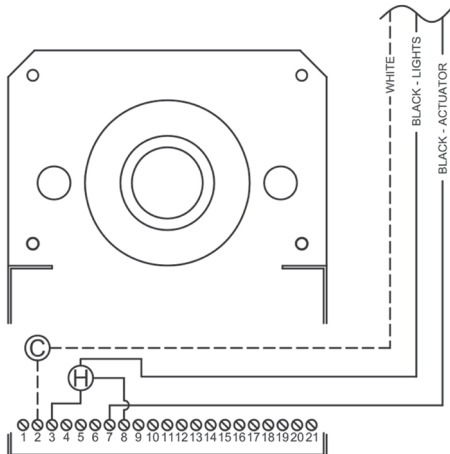

SM-501-P Smoke Detector

(120 V wiring shown above. Refer to II-SDET for 24 V installation.)

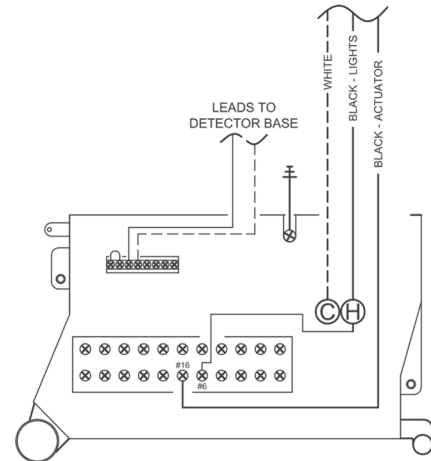

2D51 Smoke Detector

(120 V wiring shown above. Refer to II-SDET for 24 V installation.)

Damper Operation Test Box

For all MCDLG Combination Fire-Smoke and Smoke Damper Models

Factory wiring for 3-position Momentary or Toggle Test with Position Indicator and Smoke Detector

(Used only on fire-smoke dampers with ESOT)

NOTE: It is intended that an additional power lead be connected to the orange 're-open' lead such that remote opening of the damper can happen from location other than this remote test box, such as a fire control or building management system.

See page 4, Wiring Chart for additional switch package wiring details.

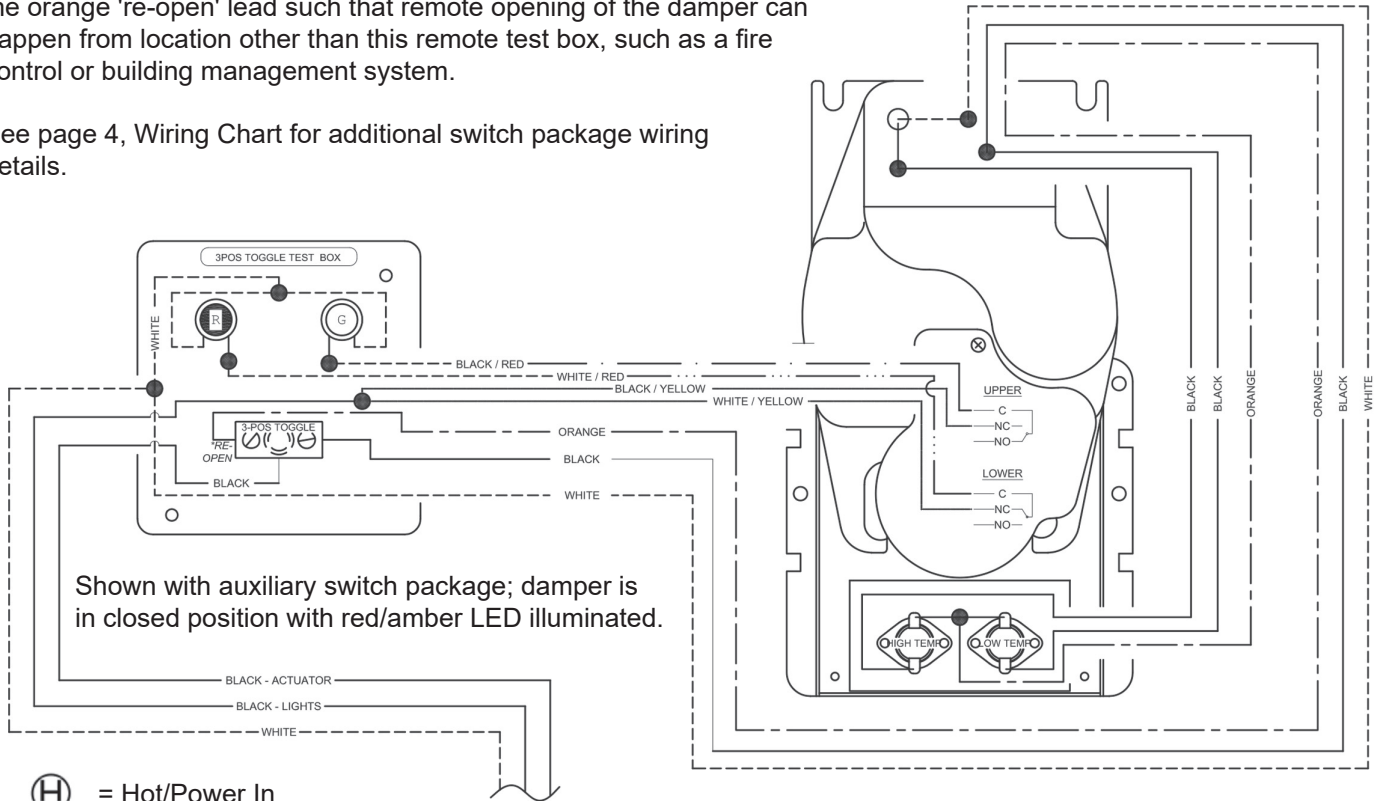

- (H)** = Hot/Power In
- (C)** = Common/Neutral In

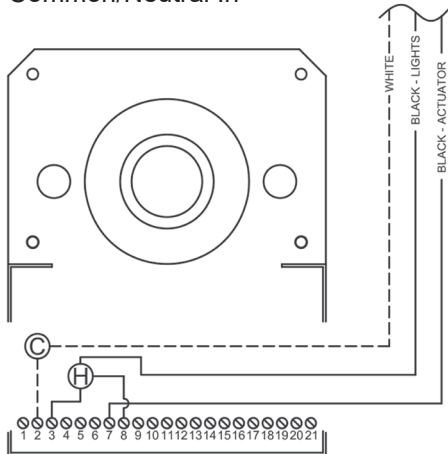

SM-501-P Smoke Detector

(120 V wiring shown above. Refer to II-SDET for 24 V installation.)

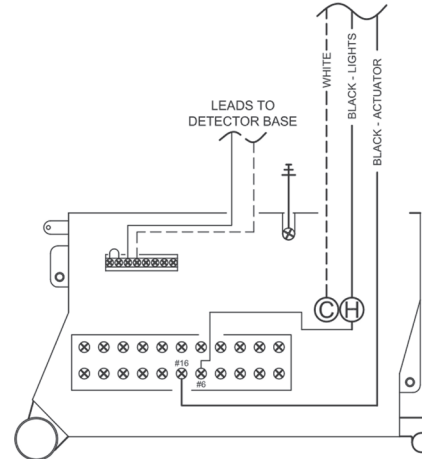

2D51 Smoke Detector

(120 V wiring shown above. Refer to II-SDET for 24 V installation.)