

Industrial Damper • 10" Deep • Airfoil Blades • Channel Frame • Galvanized Steel • 450°F Max Temperature

For use up to 20 in. w.g. static pressure

STANDARD CONSTRUCTION

- FRAME:** 2" x 10" x 2", 10 GA. galvanized steel formed channel frame.
- BLADE:** 12 GA. galvanized steel, airfoil design, to a maximum 48" length.
10 GA. galvanized steel, airfoil design, to a maximum 60" length.
- SHAFT:** 3/4" dia. plated cold-finished steel, corrosion resistant, for up to 48" in length. 1" dia. for up to 60" length.
- BEARINGS:** Stainless steel flanged sleeve, bolted to the frame.
- LINKAGE:** 1/2" dia. inter-connecting rod with trunnion pivot fasteners, located in jamb.
- OPERATOR:** Manual hand quadrant or lever arm for motor actuator. Specify type when ordering.
- FINISH:** Mill.
- TEMP. LIMIT:** 450°F
Consult the factory for temperature limits over 450°F.

OPTIONS

- Stuffing boxes and replaceable packing
- Jamb Seals - Stainless steel
- Blade Edge Seals - Stainless steel
- Flanges other than the standard 2" wide
- Finishes - Acrylic, baked enamel, etc.
- Perimeter holes: one flange or two flanges
- Other types of bearings
- Materials - Full stainless steel construction, extruded aluminum, galvanized steel, etc.

NOTES

1. 1/4" nominal deduction will be made to the opening size given.
2. Construction may be with other materials when required to meet special conditions, such as: temperature, pressure, velocity, system environment, or other specifications.
3. Approximate shipping weight is 18 lbs./sq.ft.

DAMPER SIZES

| Min. Size | Max. Size |
|-----------------------------|-------------|
| 6"W x 6"H (Single Blade) | 60"W x 96"H |
| 6"W x 12"H (Opposed) | |

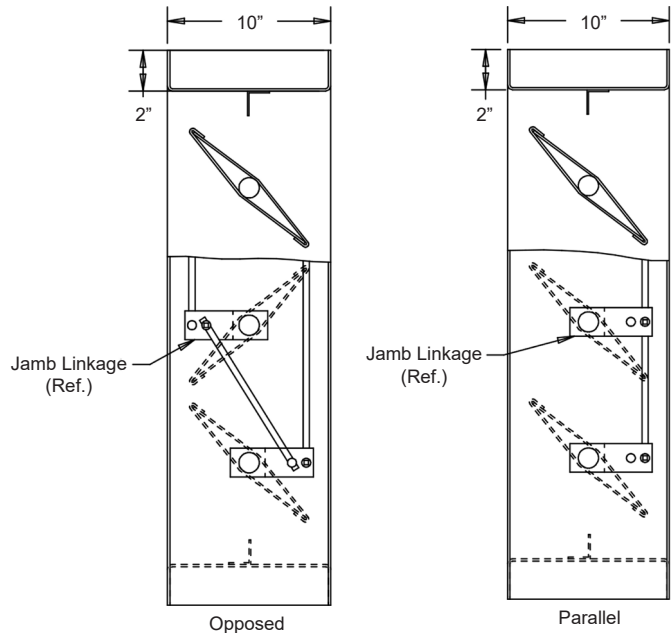
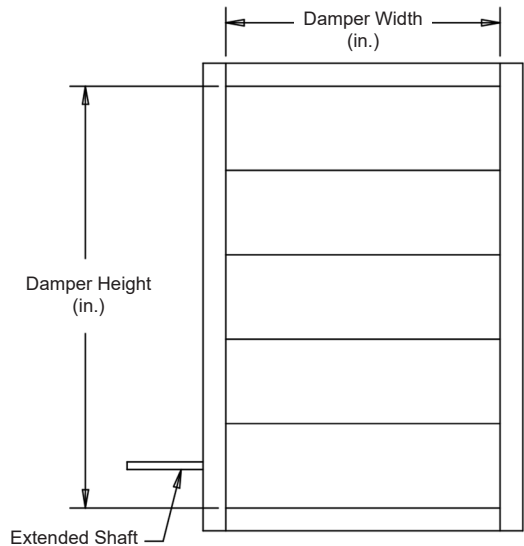

Not to scale.

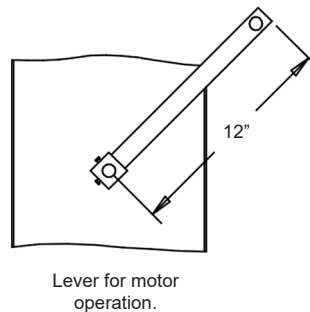
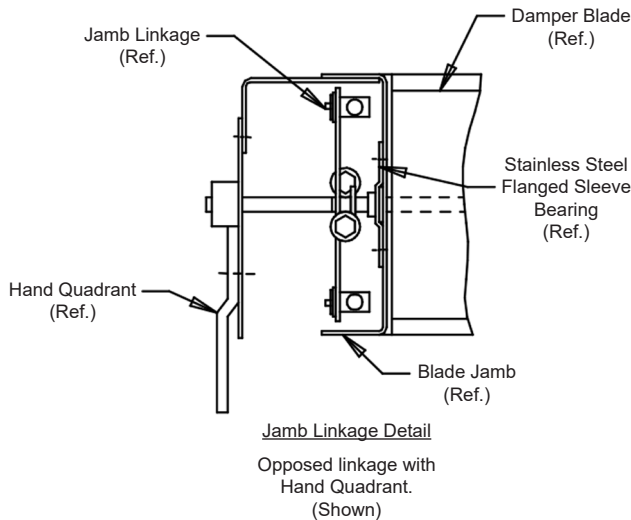

For handwritten orders, use the schedule block on page 4.

In the interest of product development, Louvers & Dampers reserves the right to make changes without notice.

www.louvers-dampers.com

450 Riverside Drive • Wyalusing PA, 18853 • Phone 570-746-1888 • Fax 570-746-9286

AIR LEAKAGE DATA

Air leakage quantities shown in the chart are results of tests per AMCA Standard 500 and are shown at 1 in. w.g. differential pressure and are corrected to .075 lb./cu.ft. air density.

Air Leakage (Total CFM)

| | | Damper Width (in. I.D.) | | | | | | | | |
|--------------------------|-----|-------------------------|-----|-----|-----|-----|-----|-----|-----|-----|
| | | 12" | 18" | 24" | 30" | 36" | 42" | 48" | 54" | 60" |
| Damper Height (in. I.D.) | 12" | 5 | 7 | 10 | 12 | 14 | 17 | 19 | 22 | 24 |
| | 24" | 10 | 14 | 19 | 24 | 29 | 34 | 39 | 43 | 48 |
| | 36" | 14 | 22 | 29 | 36 | 43 | 51 | 58 | 65 | 72 |
| | 48" | 19 | 29 | 39 | 48 | 58 | 68 | 77 | 87 | 96 |
| | 60" | 24 | 36 | 48 | 60 | 72 | 84 | 96 | 108 | 121 |
| | 72" | 29 | 43 | 58 | 72 | 87 | 101 | 116 | 130 | 145 |
| | 84" | 34 | 51 | 68 | 84 | 101 | 118 | 135 | 152 | 169 |
| | 96" | 39 | 58 | 77 | 96 | 116 | 132 | 154 | 174 | 193 |

For determining leakage values greater than 1 in. w.g. to a maximum of 20 in. w.g., use the multiplier correction chart below.

| Static Pressure (in.) | 2 | 3 | 4 | 5 | 6 | 7 | 8 | 9 | 10 | 11 | 12 | 13 | 14 | 15 | 16 | 17 | 18 | 19 | 20 |
|------------------------------|-----|-----|-----|-----|-----|-----|-----|-----|-----|-----|-----|-----|-----|-----|-----|-----|-----|-----|-----|
| Multiplier Correction Factor | 1.3 | 1.6 | 1.9 | 2.2 | 2.4 | 2.6 | 2.8 | 3.0 | 3.2 | 3.3 | 3.5 | 3.6 | 3.7 | 3.9 | 4.0 | 4.1 | 4.2 | 4.4 | 4.5 |

Air leakage ratings are based on AMCA Standard 500, using test set-up Fig. 5.4 with a damper closing torque applied to the damper of 75 in. lbs./sq.ft. of damper face area for a 60" x 96", with a minimum of 55 in. lbs./sq.ft. of a damper area for a size 60" x 8".

Damper air leakage shown is based upon publishing only the most conservative results for the Model GI51 industrial damper for an entire range of damper sizes.

To ensure proper damper operation and air leakage performance for this damper design, the static pressure and blade length limits shown below provide the necessary information and show the relationship between a damper's costs and its applications.

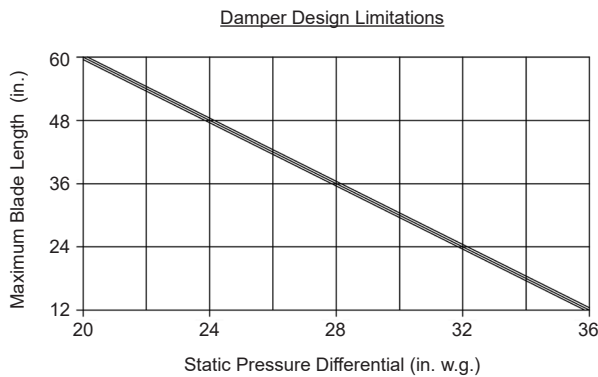

This damper's design at a blade length of 60" has a maximum allowable blade deflection of $L / 360$ for the static pressure indicated on the chart. At reduced blade lengths, higher static pressure limits can be attained without sacrificing damper operating performance characteristics.

PRESSURE DROP DATA

Pressure drop ratings are based on AMCA Standard 500, using test set-up figure 5.3 for a damper installed with duct upstream and downstream. Static pressures are corrected to .075 lb./cu.ft. air density.

