

Louvers & Dampers

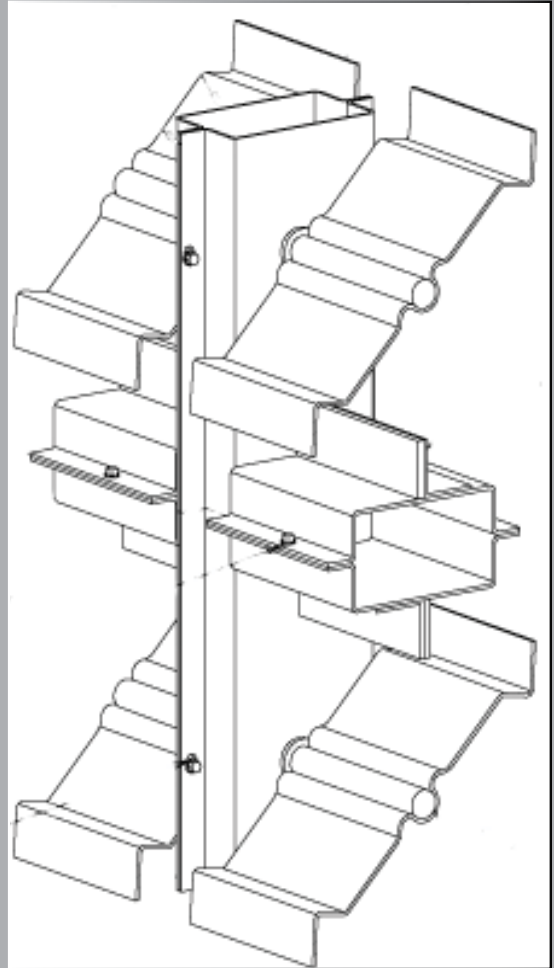
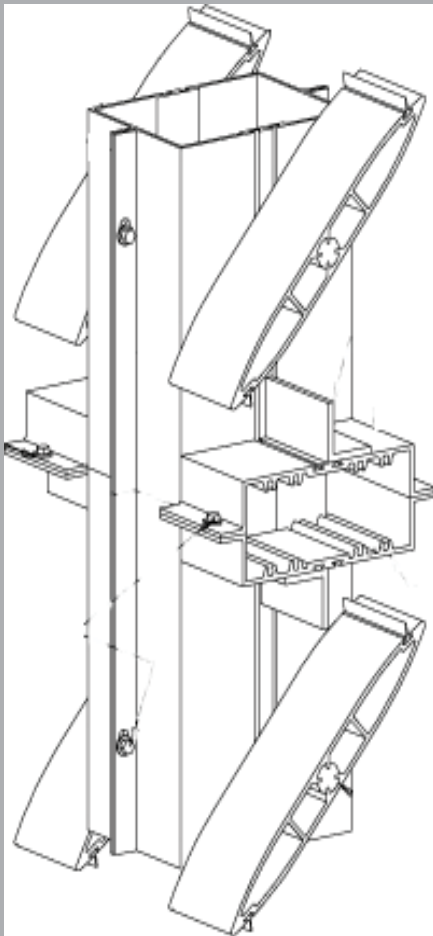

DAMPER
CONSTRUCTION
DETAILS

ALUMINUM AND STEEL CONTROL DAMPER REFERENCE CHART

DETAIL DESCRIPTION	ALUMINUM DAMPERS			STEEL DAMPERS		
	A28	A29		GD1	GD2	
EXTENDED SHAFT	1	1		5	5	
VERTICAL MULLION	2	2		6	6	
HORIZONTAL MULLION	3	3		7	7	
HORIZONTAL/VERTICAL INTERNAL MULLION	4	4		8	8	
JUMPER BRACKET	9	9		10	10	
JACKSHAFT BEARING MOUNTING BRACKET ATTACHMENT	11	11		11	11	
JACKSHAFT TO BLADE INTERCONNECTION	12	12		13	13	
JACKSHAFT COUPLING	14	14		14	14	
VERTICAL FACE JUMPER LINKAGE	15	15		16	16	
STANDARD BLADE LINKAGE DIMENSIONS	17	17		18	18	
JACKSHAFT TO JACKSHAFT INTERCONNECTION	19	19		20	20	
INTERNALLY MOUNTED PNEUMATIC "UNI-MOUNT" DRIVING TO A BLADE CLIP	21	21		21	21	
INTERNALLY MOUNTED ELECTRIC "UNI-MOUNT" DRIVING TO A BLADE CLIP	22	22		22	22	
INTERNALLY MOUNTED ELECTRIC OPERATOR BRACKET DRIVING TO A BLADE CLIP	23	23		23	23	
EXTERNALLY MOUNTED ELECTRIC OPERATOR DRIVING TO AN EXTENDED SHAFT	24	24		24	24	
EXTERNALLY MOUNTED PNEUMATIC OPERATOR DRIVING TO AN EXTENDED SHAFT	25	25		25	25	
INTERNALLY MOUNTED PNEUMATIC "UNI-MOUNT" DRIVING TO A JACKSHAFT	26	26		26	26	
INTERNALLY MOUNTED ELECTRIC "UNI-MOUNT" DRIVING TO A JACKSHAFT	27	27		27	27	
INTERNALLY MOUNTED ELECTRIC OPERATOR BRACKET DRIVING TO A JACKSHAFT	28	28		28	28	
JAMB LINKAGE	29	29		30	30	
FACE LINKAGE ARRANGEMENTS	-	-		32	32	

NOTES:

1. DETAILS SHOW GENERAL CONSTRUCTION ONLY FOR ALUMINUM AND STEEL DAMPERS. THE L & D PINLOCK DAMPER AND THERMAL BREAK DAMPER AND THEIR DETAILS ARE NOT PROVIDED IN THIS REFERENCE.
2. L & D DAMPERS ARE SELF SUPPORTING AFTER INSTALLATION IN ONLY ITS LARGEST SINGLE SECTION SIZE. MULTI-DAMPER SECTION ASSEMBLIES REQUIRE BRACING TO SUPPORT DAMPER WEIGHT AND SYSTEM PRESSURE AND SHALL BE FURNISHED AND INSTALLED BY OTHERS UNLESS OTHERWISE NOTED.
3. FACE JACKSHAFT AND INTERNAL OPERATOR MOUNTING BRACKETS ARE SHIPPED LOOSE UNLESS OTHERWISE SPECIFIED.

DAMPER TAGGING

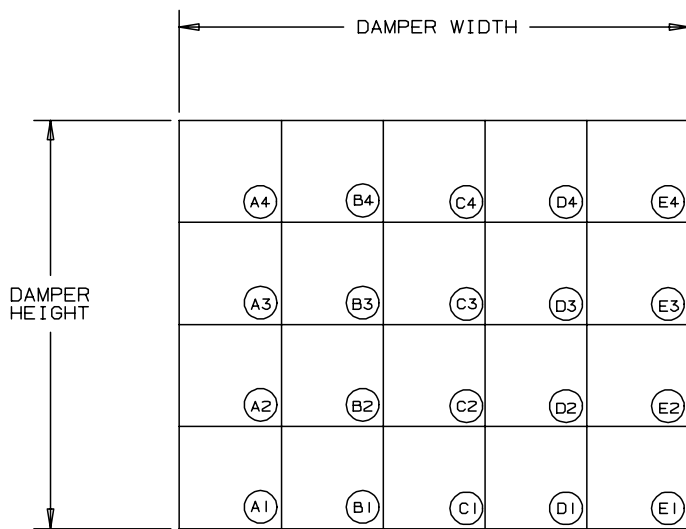

REAR ELEVATION

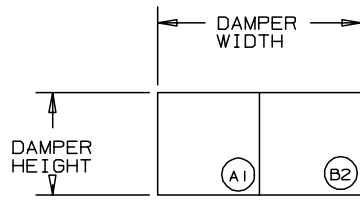

REAR ELEVATION

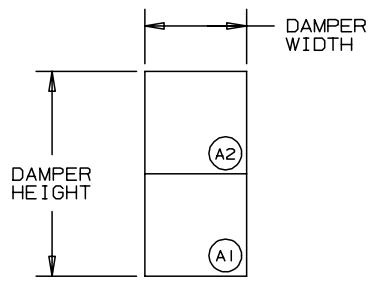

REAR ELEVATION

•• ALL TAG IDENTIFICATION WILL BE LOCATED AT THE REAR OF ALL DAMPER SECTIONS, IN THE LOCATIONS SHOWN ON THE ABOVE ELEVATIONS. TAGS WILL BE APPROX. 1 1/4" DIA. ALUMINUM, WITH 1/4" HIGH LETTERING STAMPED INTO THE ALUMINUM. TAGS WILL BE RIVETED TO THE BOTTOM HALF OF THE FIRST BLADE OF EACH SECTION.

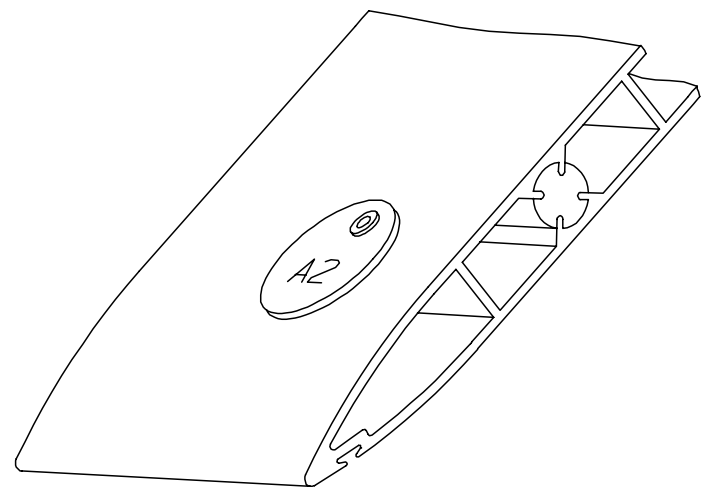

DAMPER TAG MOUNTING
DETAIL

• FRAME MEMBERS NOT SHOWN FOR CLARITY.

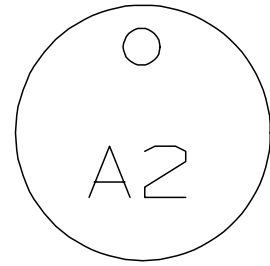

DAMPER TAG
DETAIL

TYPICAL SCHEMATIC DAMPER ELEVATIONS

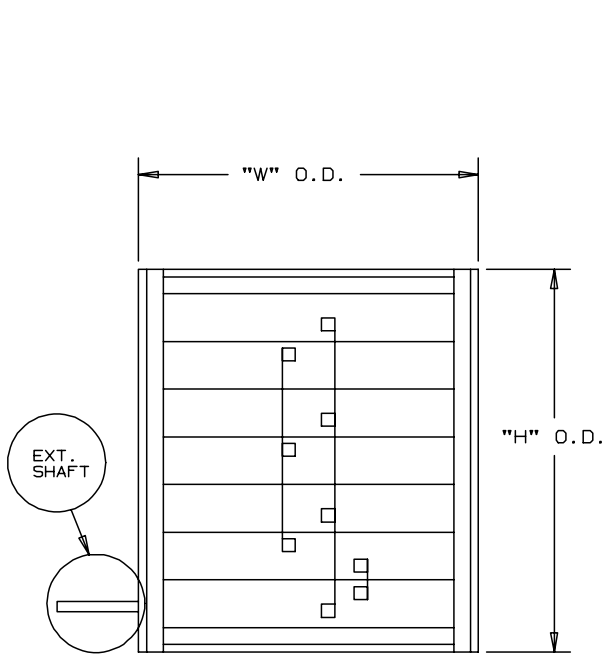

DAMPER TYPE # 1
SINGLE PANEL WITH EXTENDED SHAFT

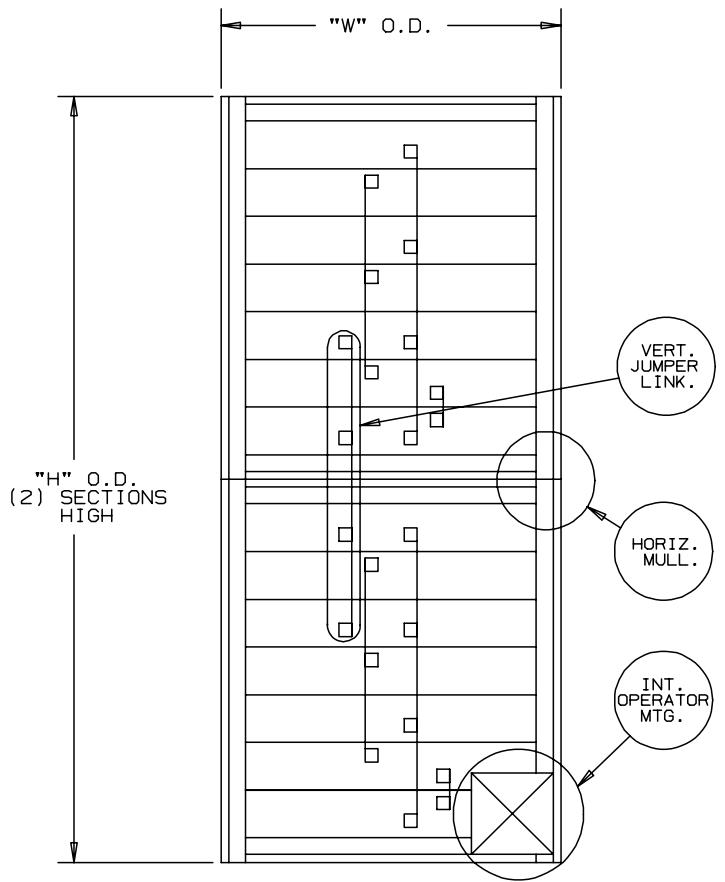

DAMPER TYPE # 2
HORIZONTAL MULLION WITH VERTICAL JUMPER LINKAGE AND INTERNALLY MOUNTED OPERATOR ONE SECTION WIDE BY TWO SECTIONS HIGH

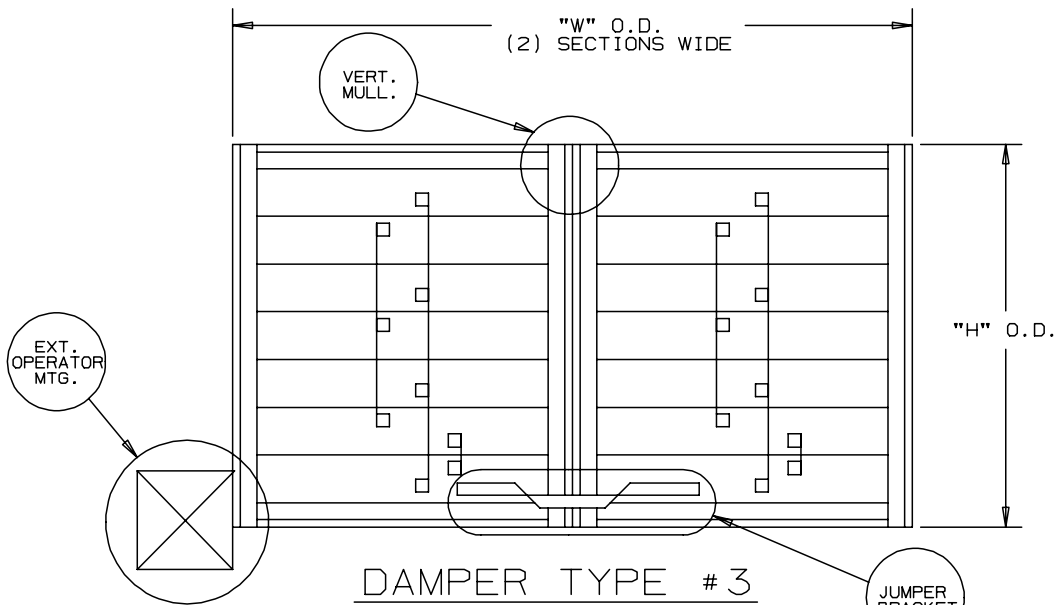

DAMPER TYPE # 3
VERTICAL MULLION WITH JUMPER BRACKET, EXTENDED SHAFT AND EXTERNALLY MOUNTED OPERATOR TWO SECTIONS WIDE BY ONE SECTION HIGH

TYPICAL SCHEMATIC DAMPER ELEVATIONS

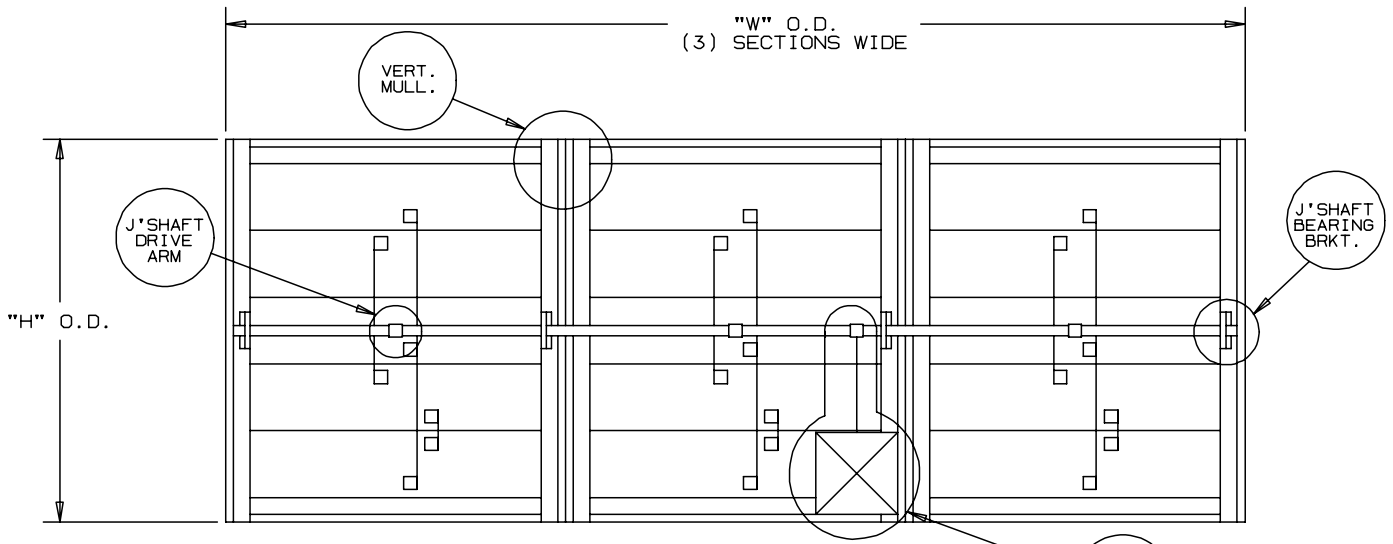

DAMPER TYPE #4

VERTICAL MULLIONS WITH JACKSHAFTING AND INTERNALLY MOUNTED OPERATOR DRIVING TO JACKSHAFTING MULTI-SECTIONS WIDE BY ONE SECTION HIGH

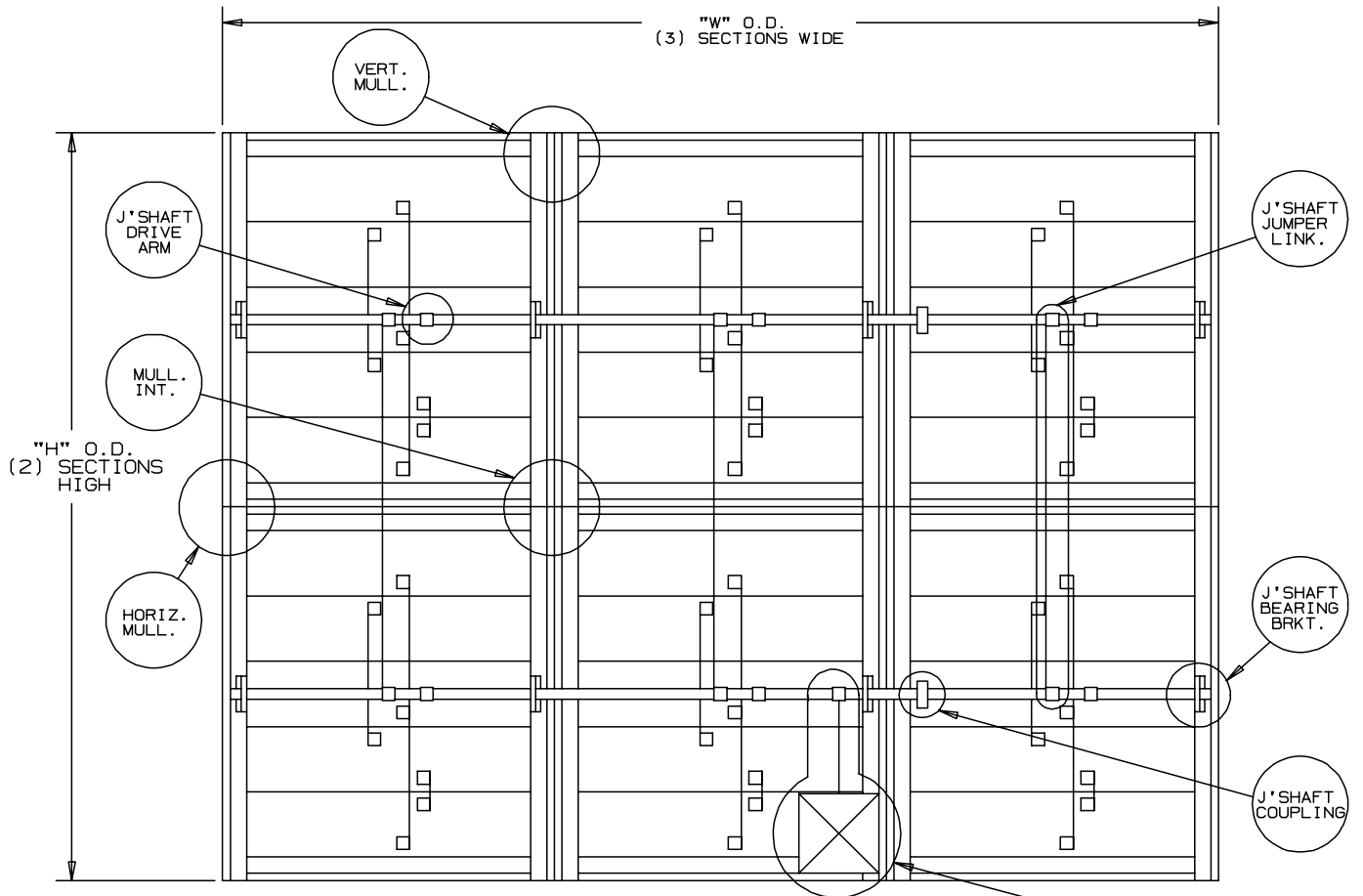

DAMPER TYPE #5

VERTICAL AND HORIZONTAL MULLIONS WITH INTERCONNECTED JACKSHAFTING AND INTERNALLY MOUNTED OPERATOR DRIVING TO LOWER JACKSHAFT MULTI-SECTIONS WIDE BY MULTI-SECTIONS HIGH

EXTRUDED ALUMINUM DAMPER DETAILS

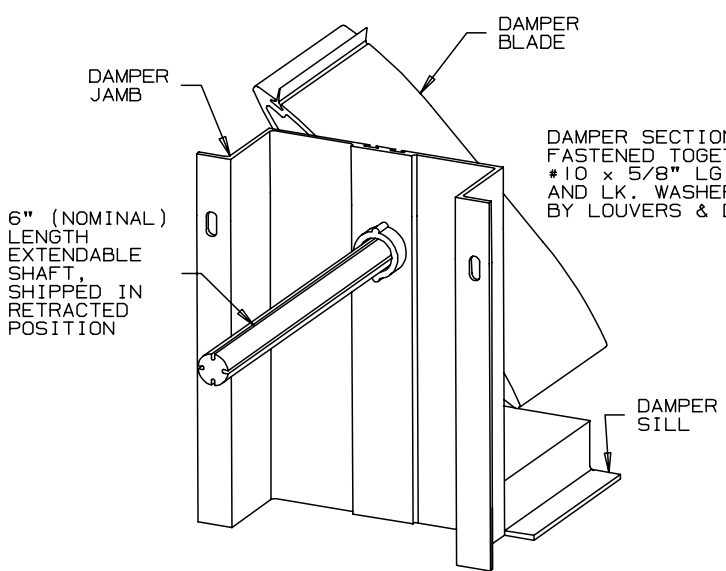

DETAIL # 1

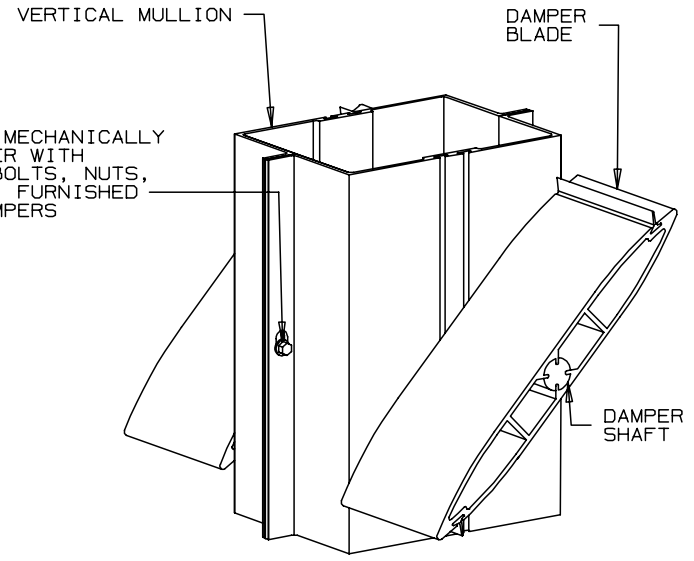

DETAIL # 2

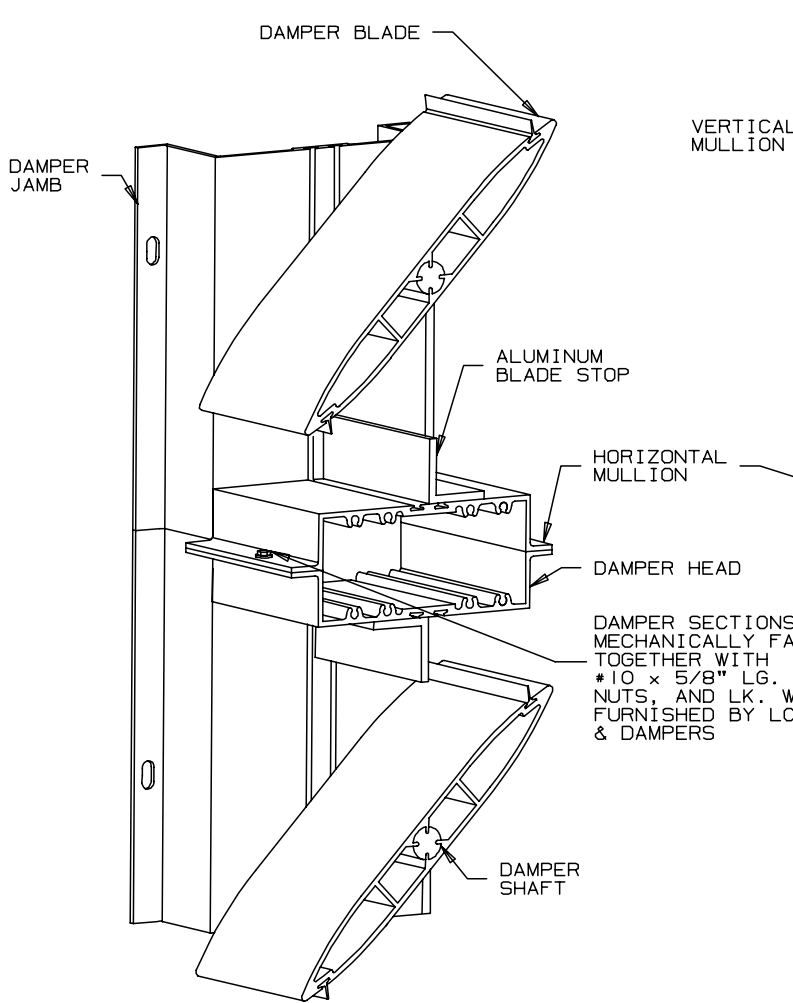

DETAIL # 3

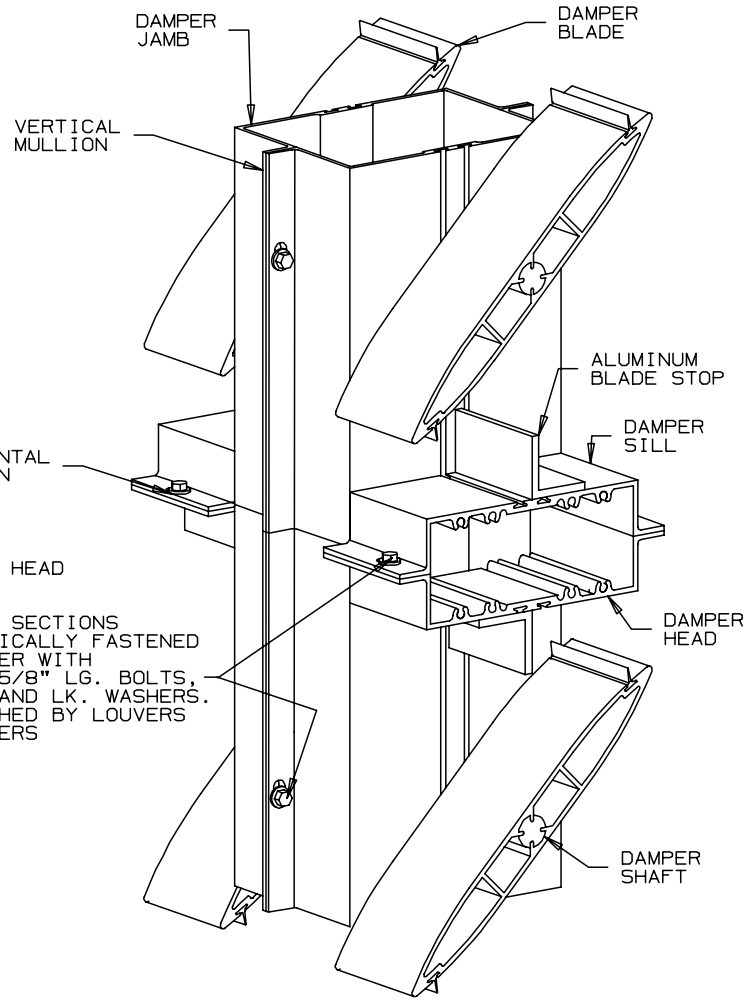

DETAIL # 4

DAMPER SECTIONS MECHANICALLY FASTENED TOGETHER WITH #10 x 5/8" LG. BOLTS, NUTS, AND LK. WASHERS. FURNISHED BY LOUVERS & DAMPERS

DAMPER SECTIONS MECHANICALLY FASTENED TOGETHER WITH #10 x 5/8" LG. BOLTS, NUTS, AND LK. WASHERS. FURNISHED BY LOUVERS & DAMPERS

FABRICATED STEEL DAMPER DETAILS

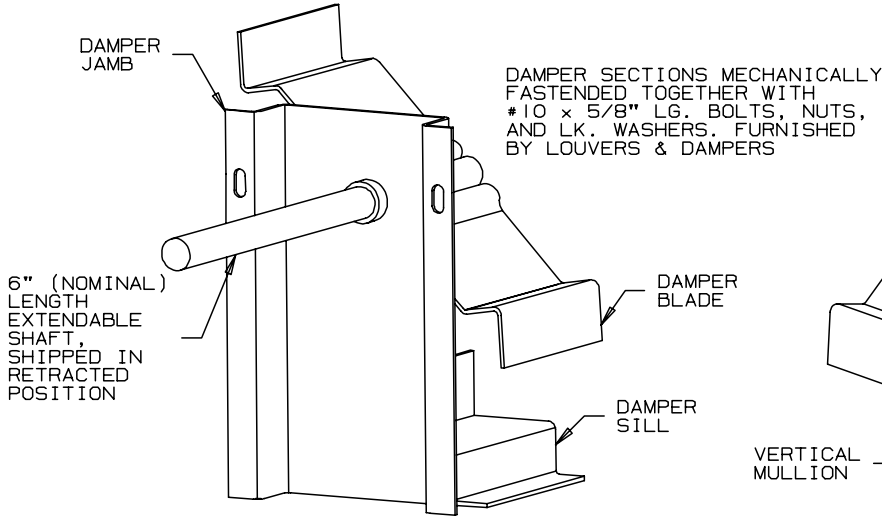

DETAIL #5

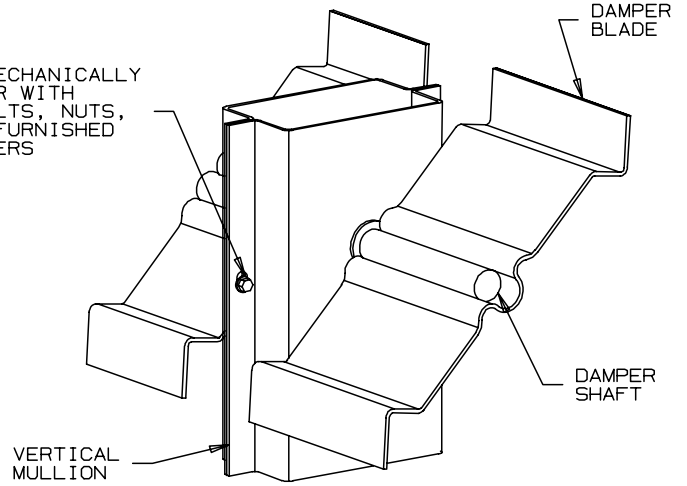

DETAIL #6

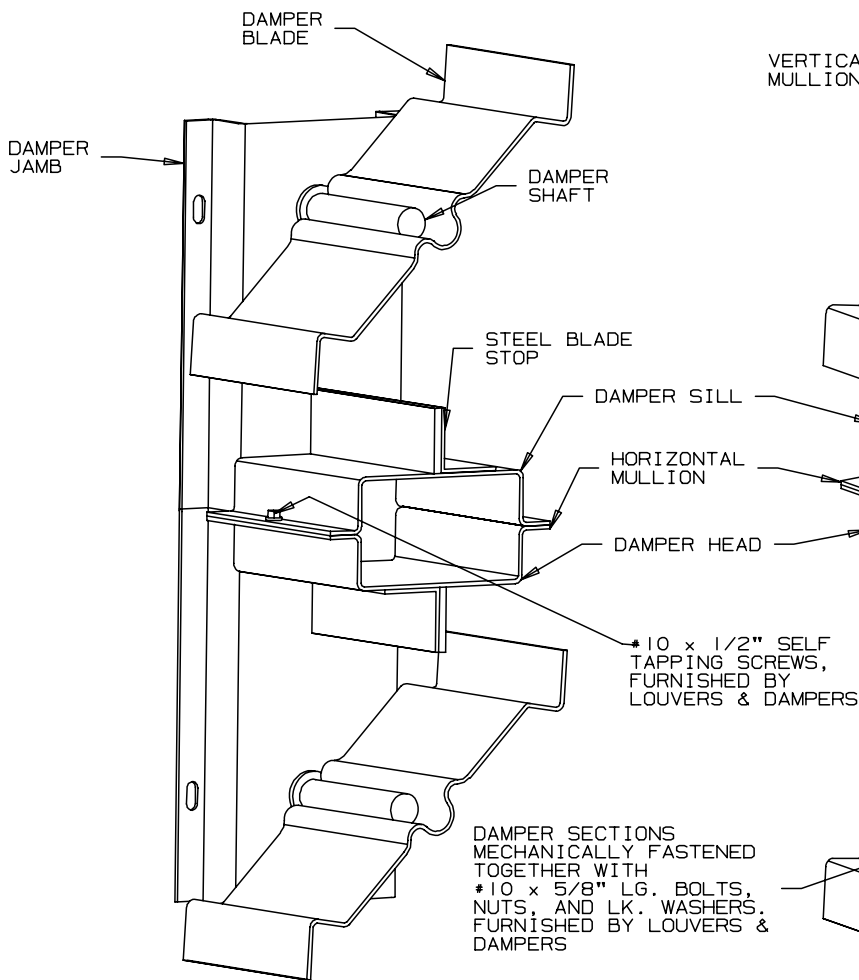

DETAIL #7

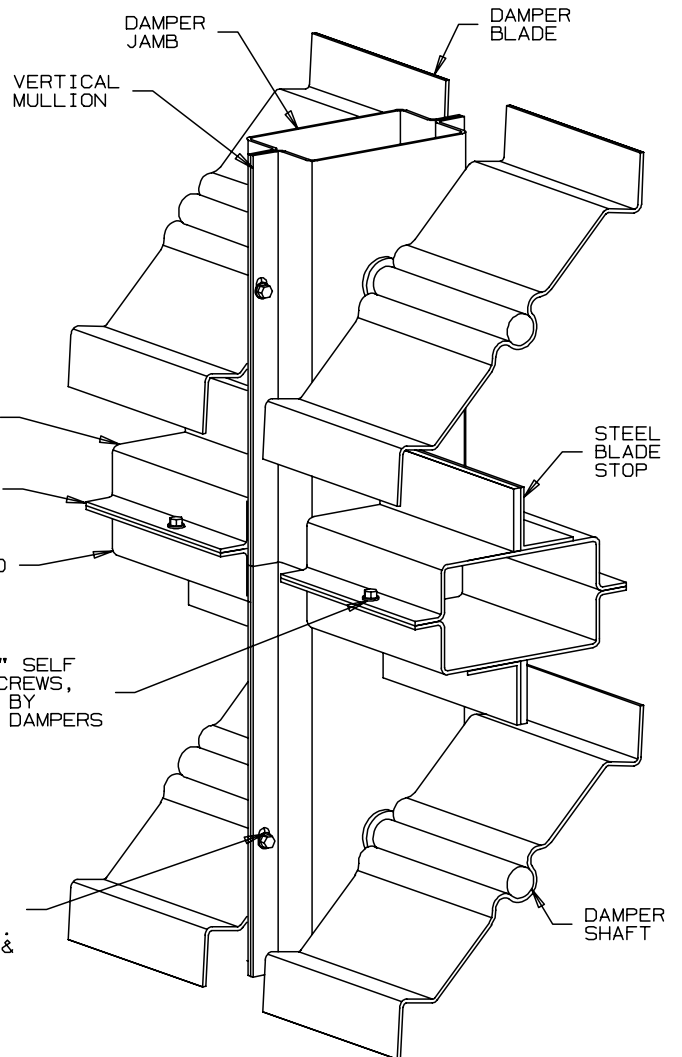

DETAIL #8

DAMPER INTERCONNECTING DETAILS

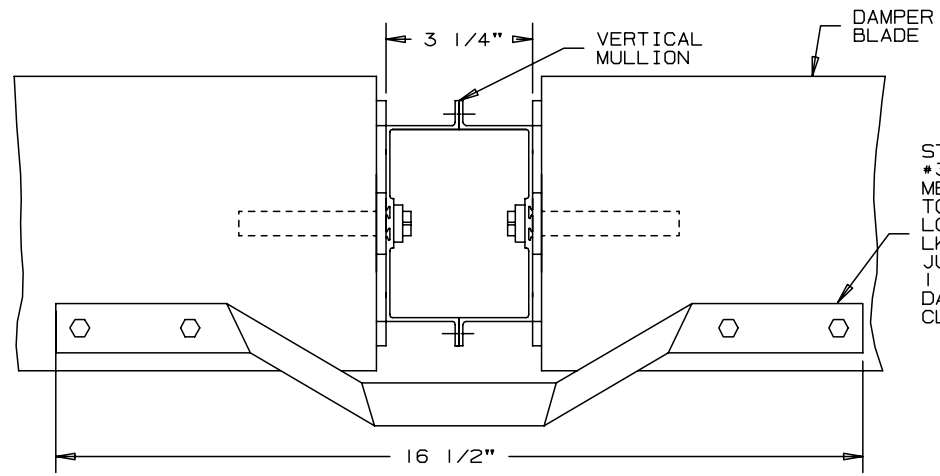

STEEL JUMPER BRACKET #38-0018-01, MECHANICALLY FASTENED TO BLADE WITH #10 x 1" LG. BOLTS, NUTS, AND LK. WASHERS
 JUMPER BRACKET EXTENDS 1 1/2" FROM FACE OF DAMPER FRAME IN THE CLOSED POSITION

DETAIL # 9

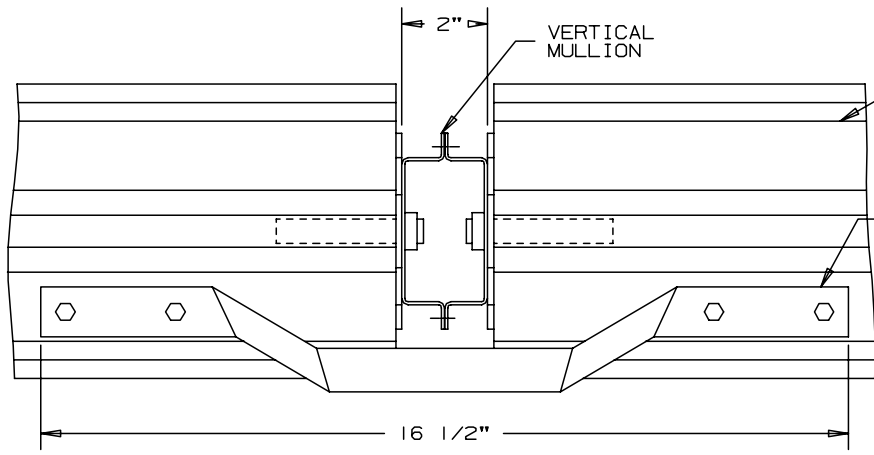

STEEL JUMPER BRACKET #38-0017-01, MECHANICALLY FASTENED TO BLADE WITH #10 x 5/8" LG. BOLTS, NUTS, AND LK. WASHERS
 JUMPER BRACKET EXTENDS 1" FROM FACE OF DAMPER FRAME IN THE CLOSED POSITION

DETAIL # 10

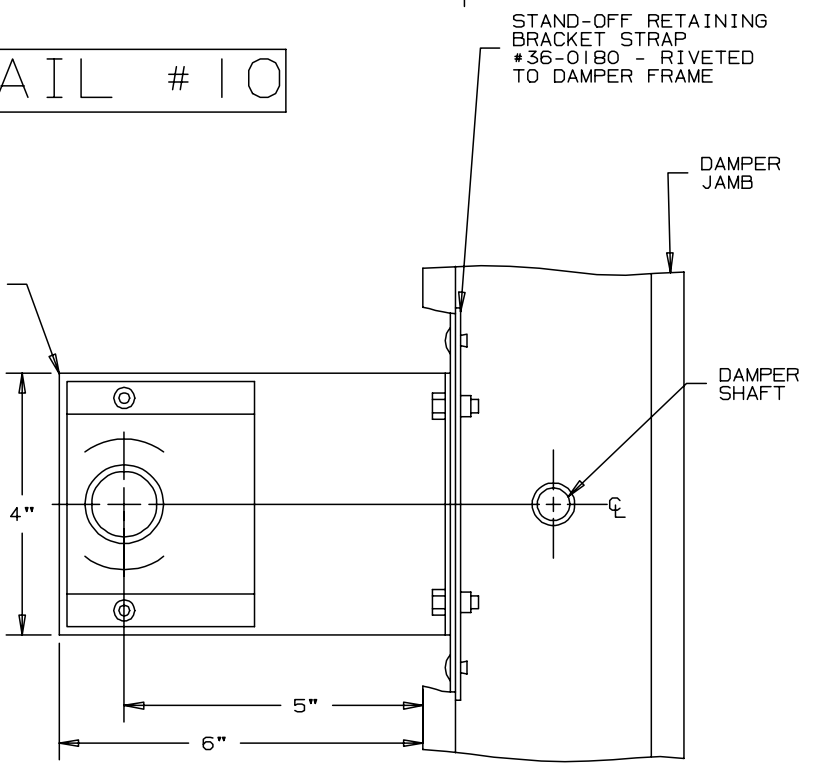
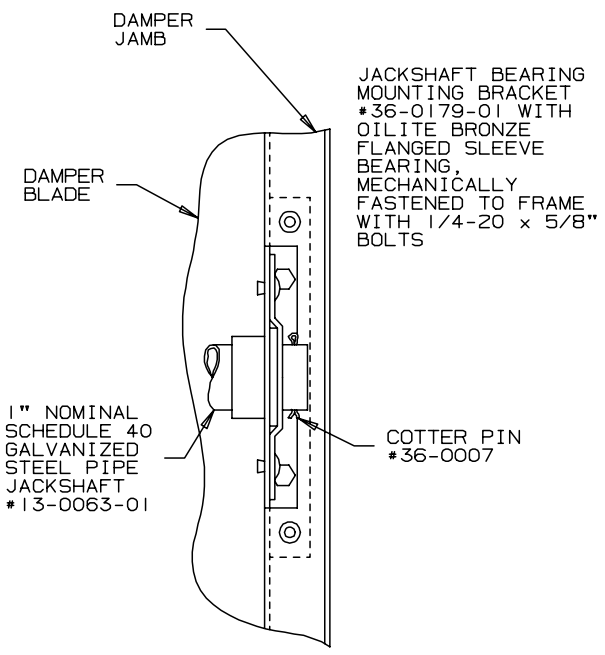

DETAIL # 11

DAMPER INTERCONNECTING DETAILS

H.D. DRIVE ARM #36-0168-05
WITH TRUNNION #36-0113-02,
CELCON BEARING #34-0004,
AND NYLON WASHER #34-0054
AND 5/16" DIA. ALUMINUM
INTERCONNECTING ROD

BLADE CLIP #38-0120-01
WITH TRUNNION #36-0113-02,
CELCON BEARING #34-0004,
AND NYLON WASHER #34-0054
MECHANICALLY FASTENED TO
DAMPER BLADE WITH #10 X 1" LG.
BOLTS, NUTS AND LK. WASHERS

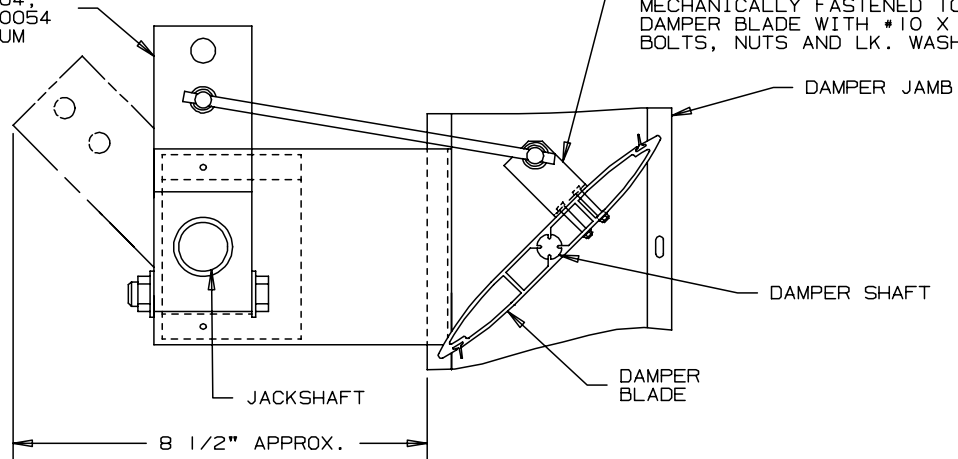

DETAIL # 12

H.D. DRIVE ARM #36-0168-05
WITH TRUNNION #36-0113-02,
CELCON BEARING #34-0004,
AND NYLON WASHER #34-0054
AND 5/16" DIA. ALUMINUM
INTERCONNECTING ROD

BLADE CLIP #38-0120-01
WITH TRUNNION #36-0113-02,
CELCON BEARING #34-0004,
AND NYLON WASHER #34-0054
MECHANICALLY FASTENED TO
DAMPER BLADE WITH #10 X 1" LG.
BOLTS, NUTS AND LK. WASHERS

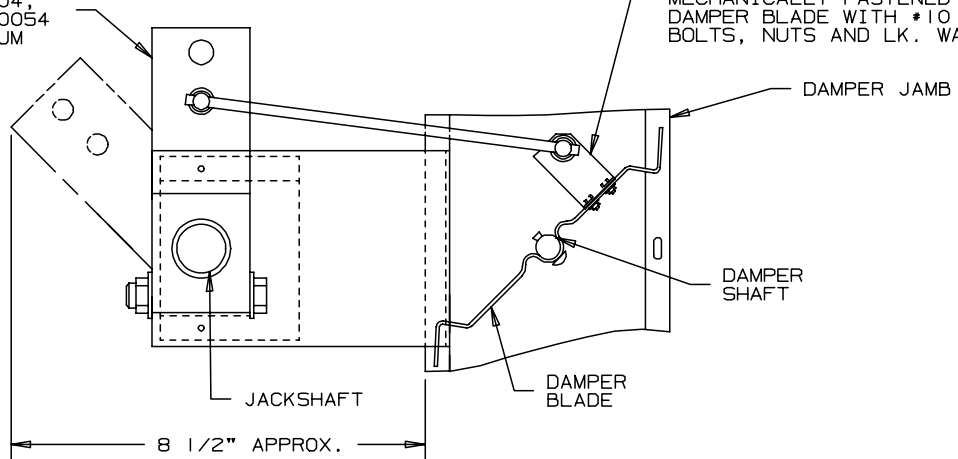

DETAIL # 13

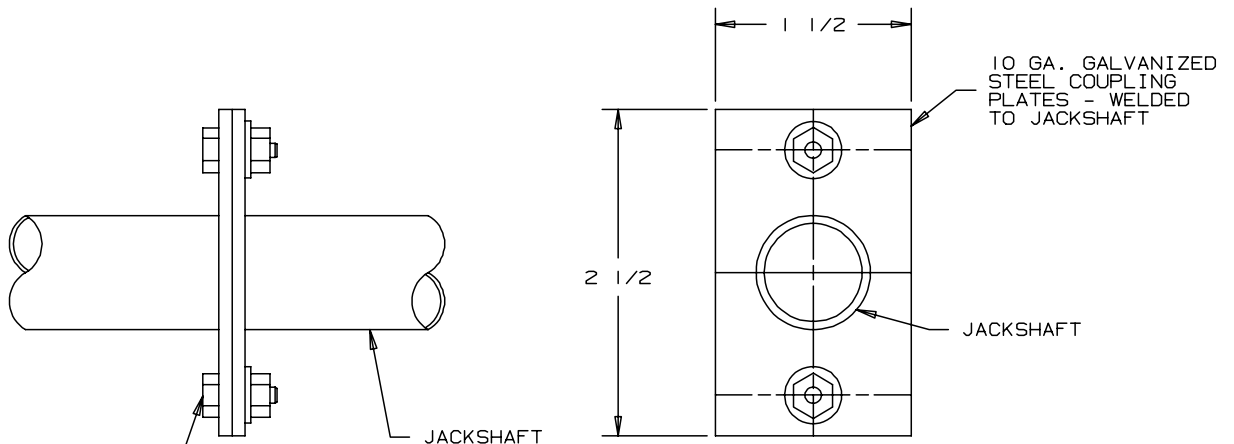

1/4 X 3/4" LG. BOLTS
WITH NUTS AND LK.
WASHERS

DETAIL # 14

DAMPER INTERCONNECTING DETAILS

INTERCONNECTING LINKAGE
 CONSISTING OF: CHEVRON
 #38-0055-01 WITH
 TRUNNION #36-0113-02,
 CELCON BEARING #34-0004,
 NYLON WASHER #34-0054,
 AND 5/16" DIA. ALUMINUM
 INTERCONNECTING ROD.
 - CHEVRON RIVETED TO BLADE

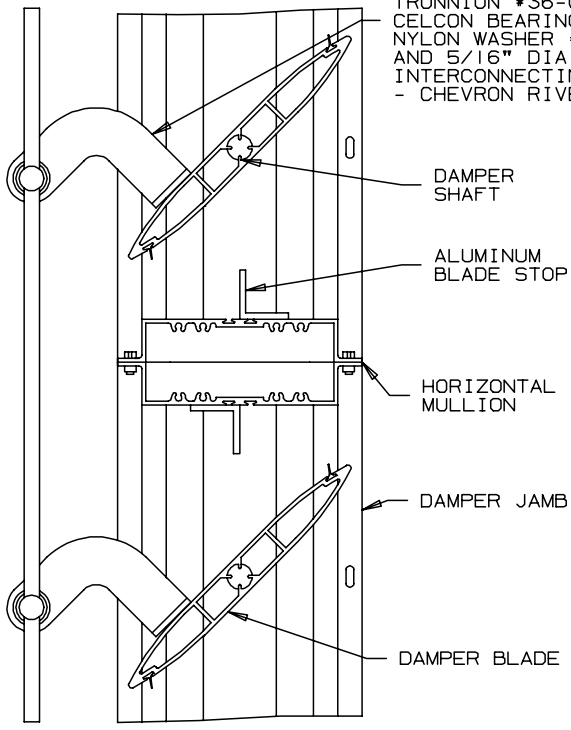

DETAIL # 15

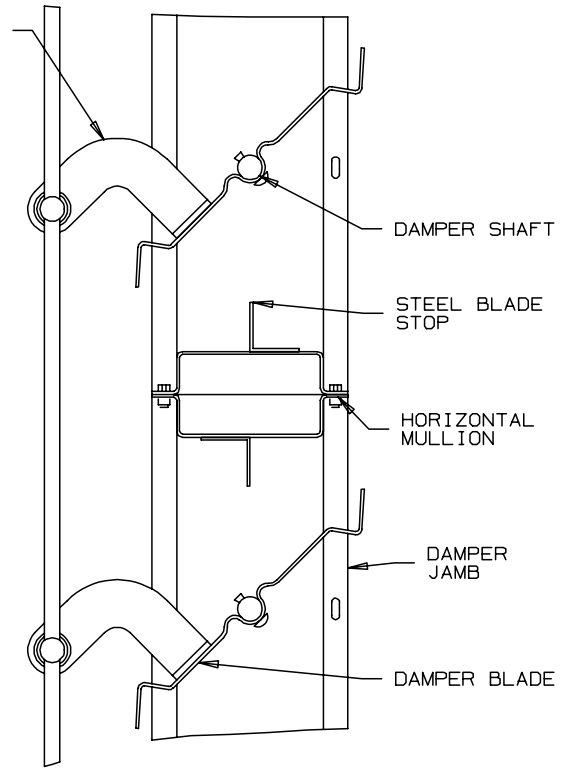

DETAIL # 16

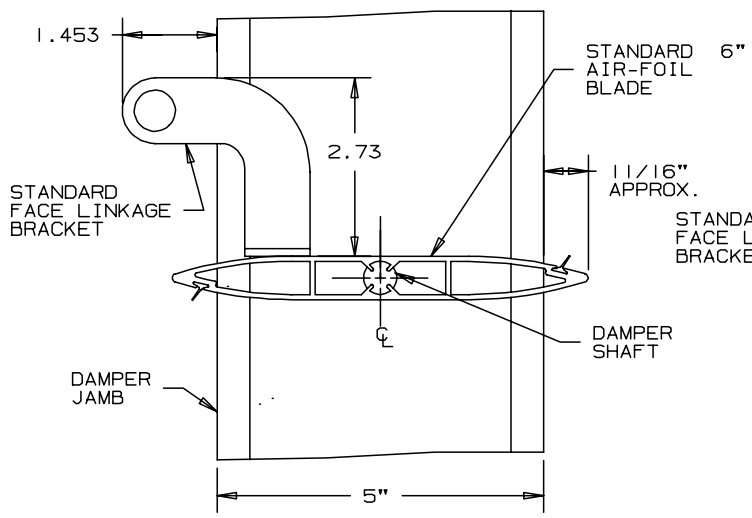

DETAIL # 17

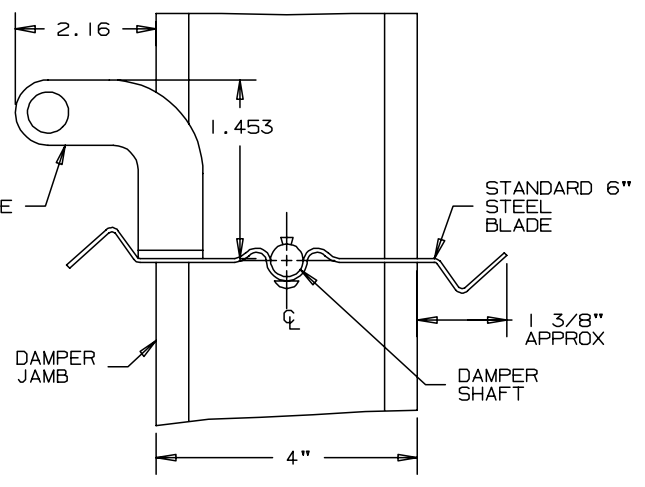

DETAIL # 18

DAMPER INTERCONNECTING DETAILS

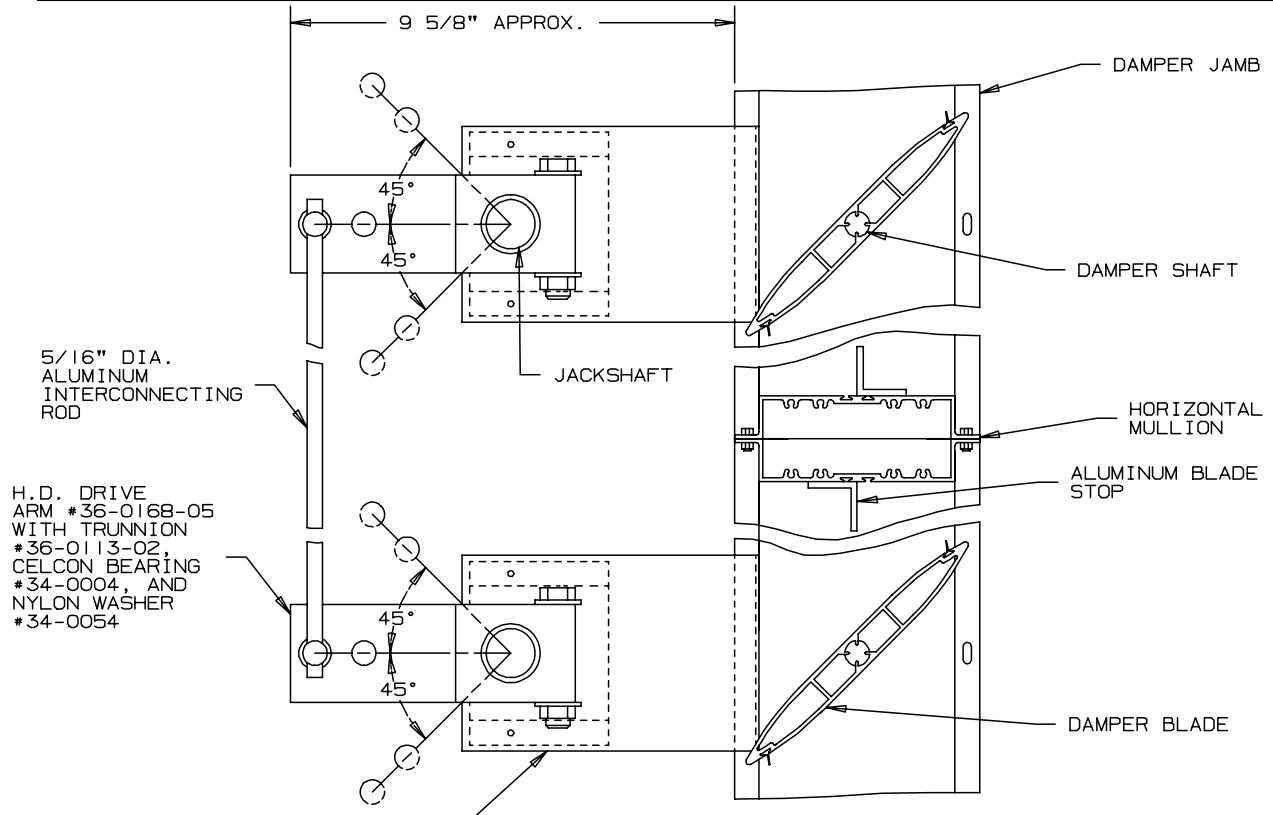

JACKSHAFT BEARING MOUNTING BRACKET #36-0179-01 - MECHANICALLY FASTENED TO FRAME (SEE DETAIL #11 FOR MOUNTING DETAIL)

DETAIL # 19

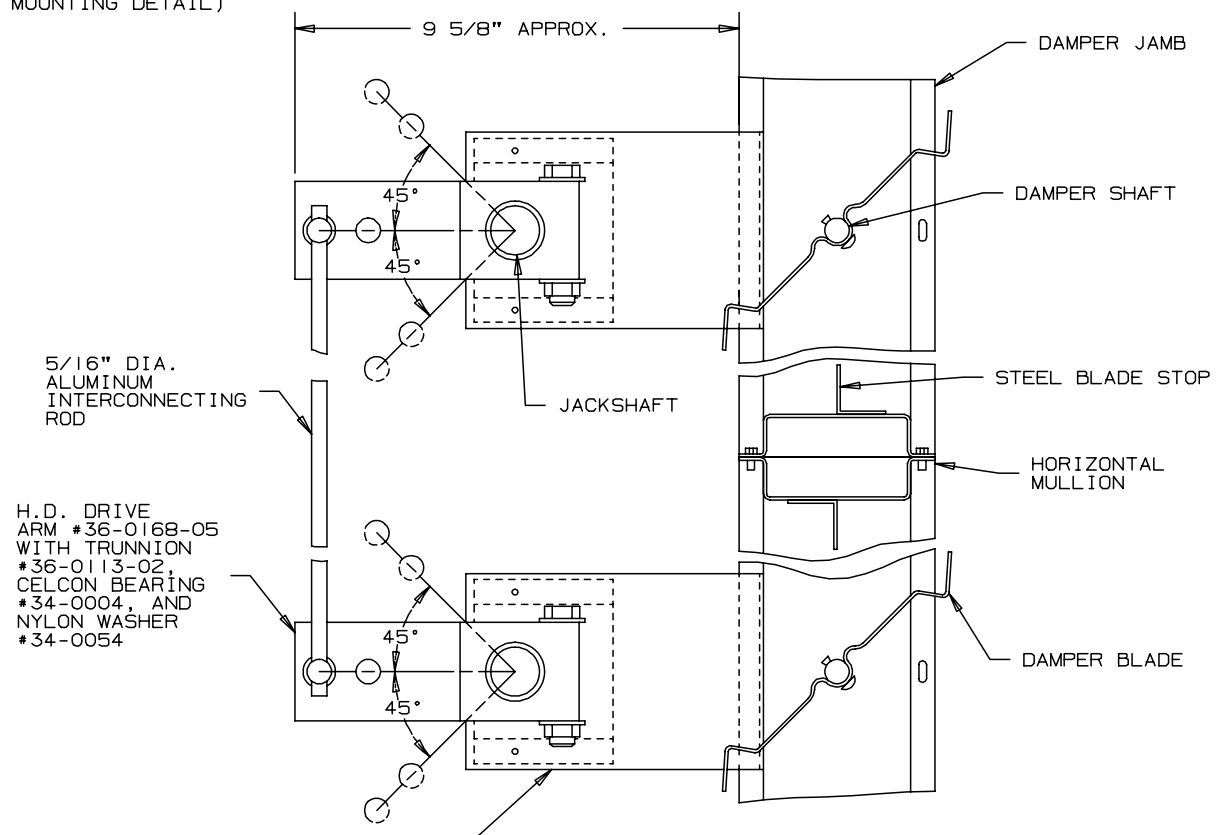

JACKSHAFT BEARING MOUNTING BRACKET #36-0179-01 - MECHANICALLY FASTENED TO FRAME (SEE DETAIL #11 FOR MOUNTING DETAIL)

DETAIL # 20

OPERATOR MOUNTING DETAILS

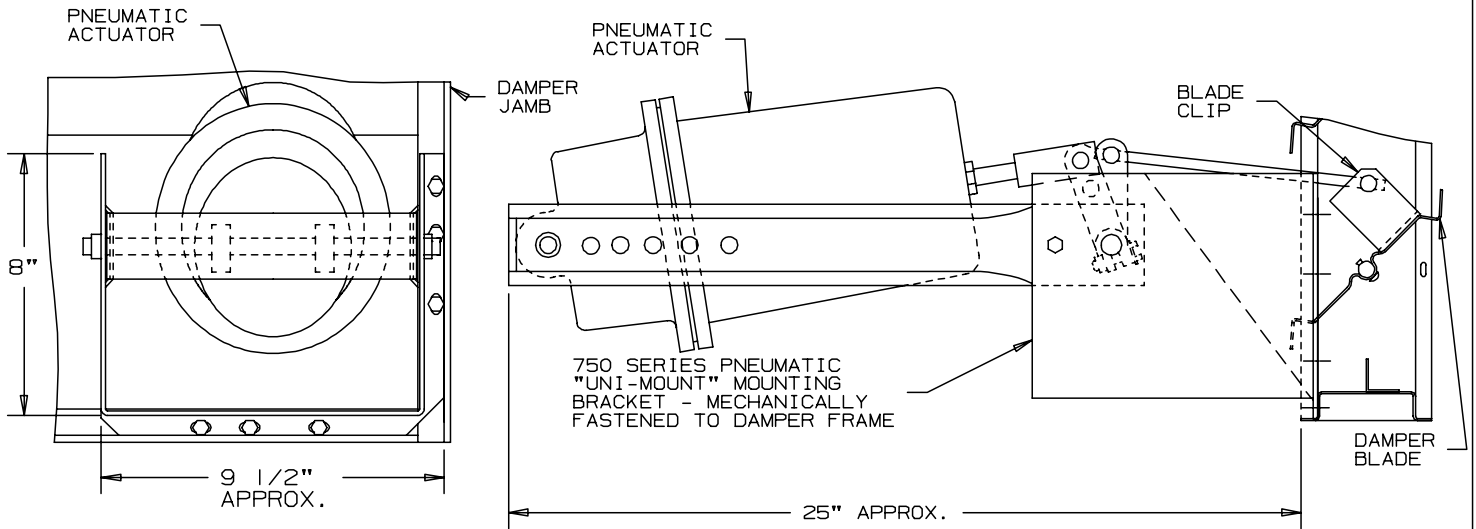

DETAIL # 21

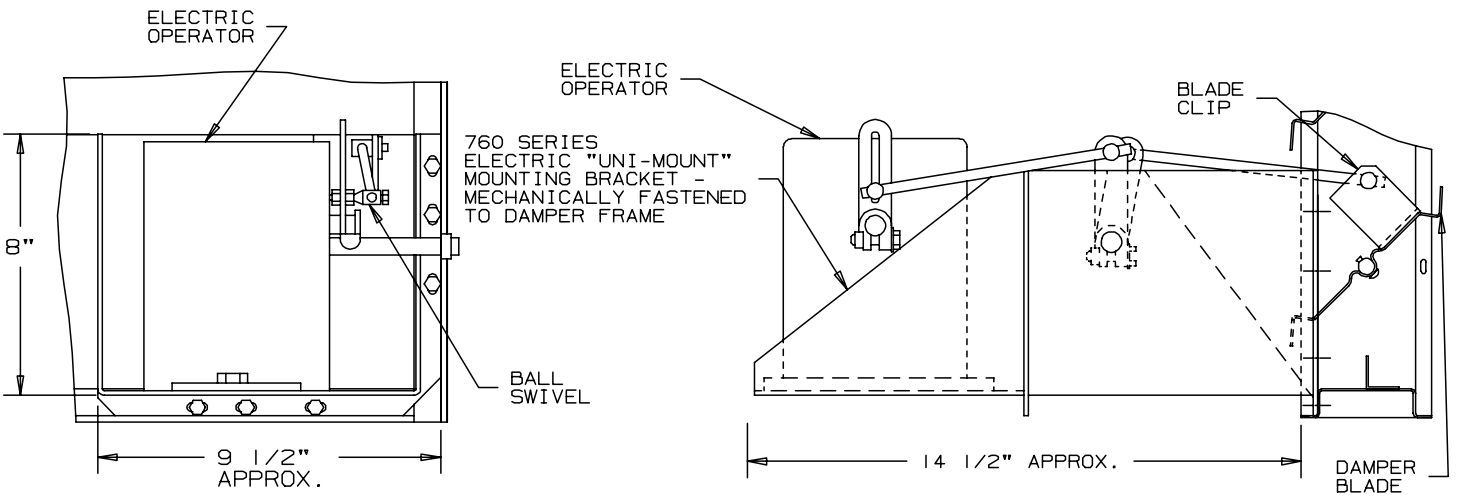

DETAIL # 22

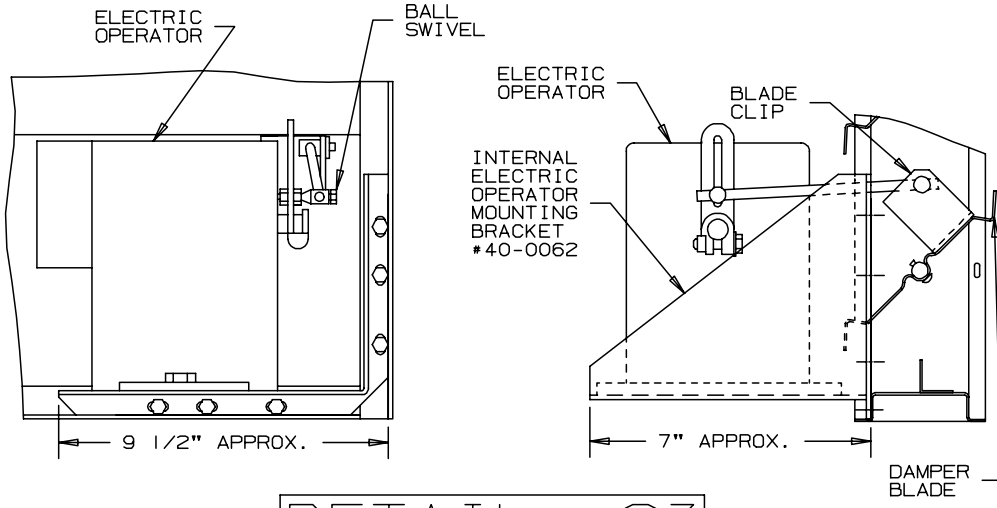

DETAIL # 23

OPERATOR MOUNTING DETAILS

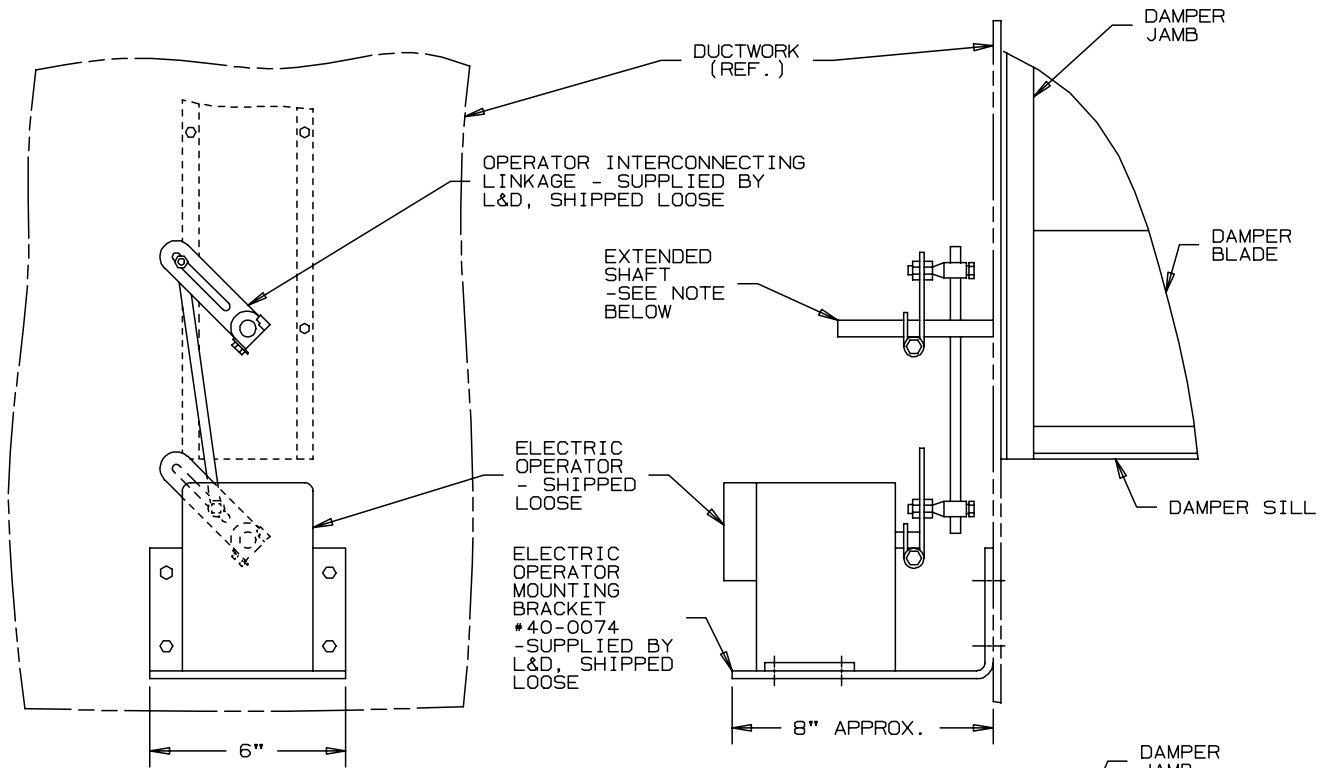

DETAIL # 24

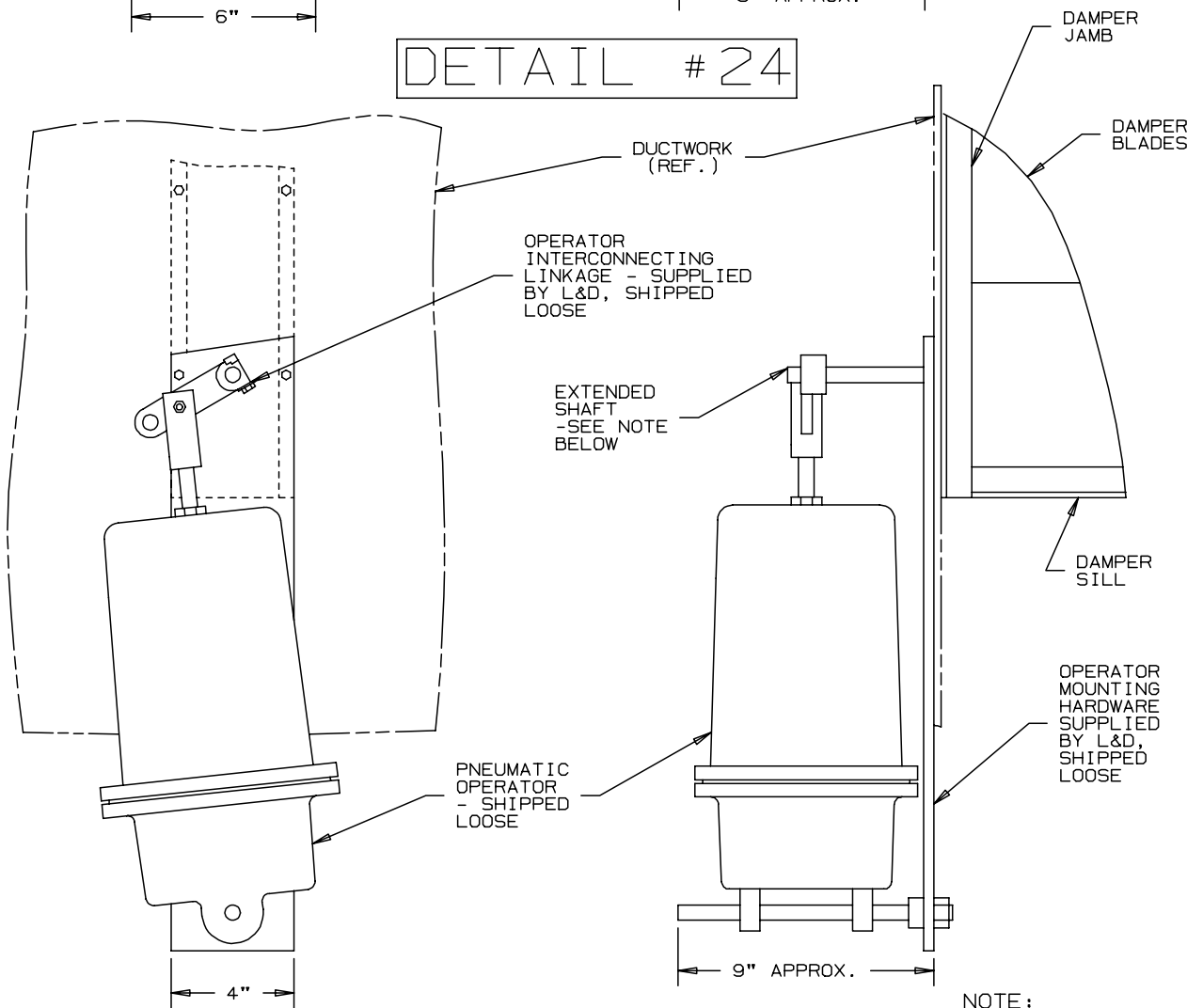

DETAIL # 25

NOTE:
CUSTOMER TO PROVIDE
CLEARANCE HOLE IN
DUCTWORK FOR EXTENDED
SHAFT.

OPERATOR MOUNTING DETAILS

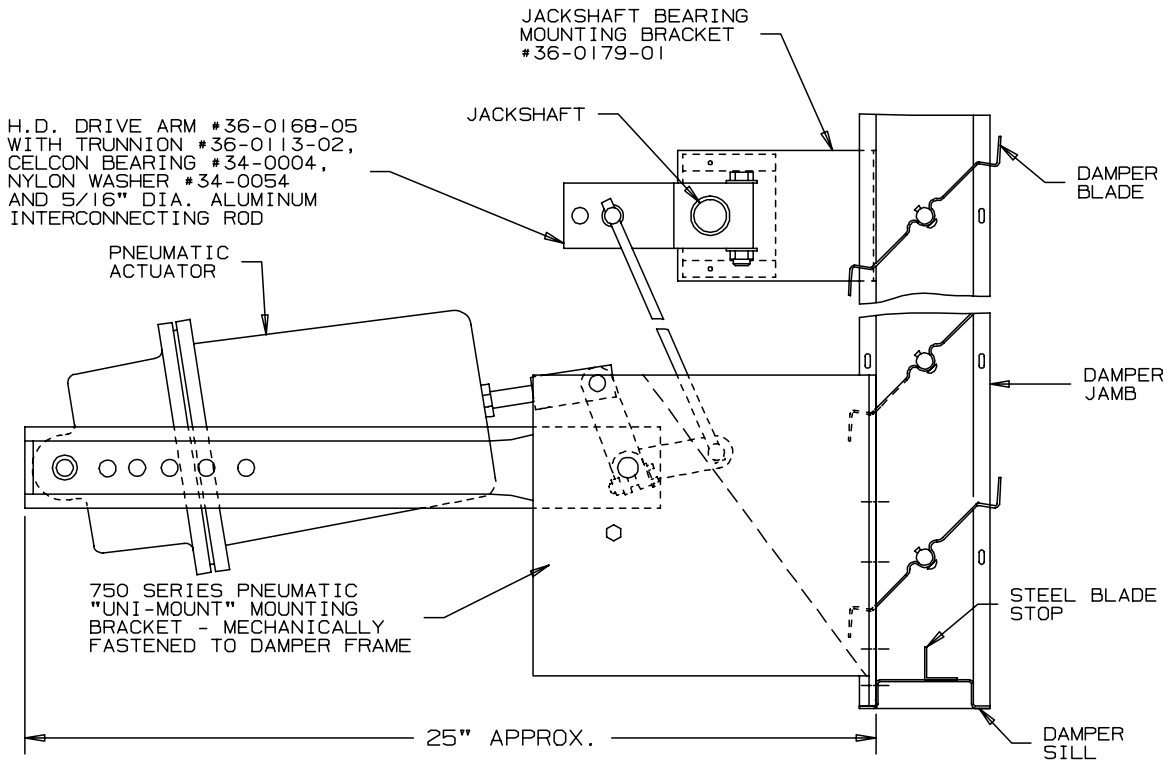

DETAIL # 26

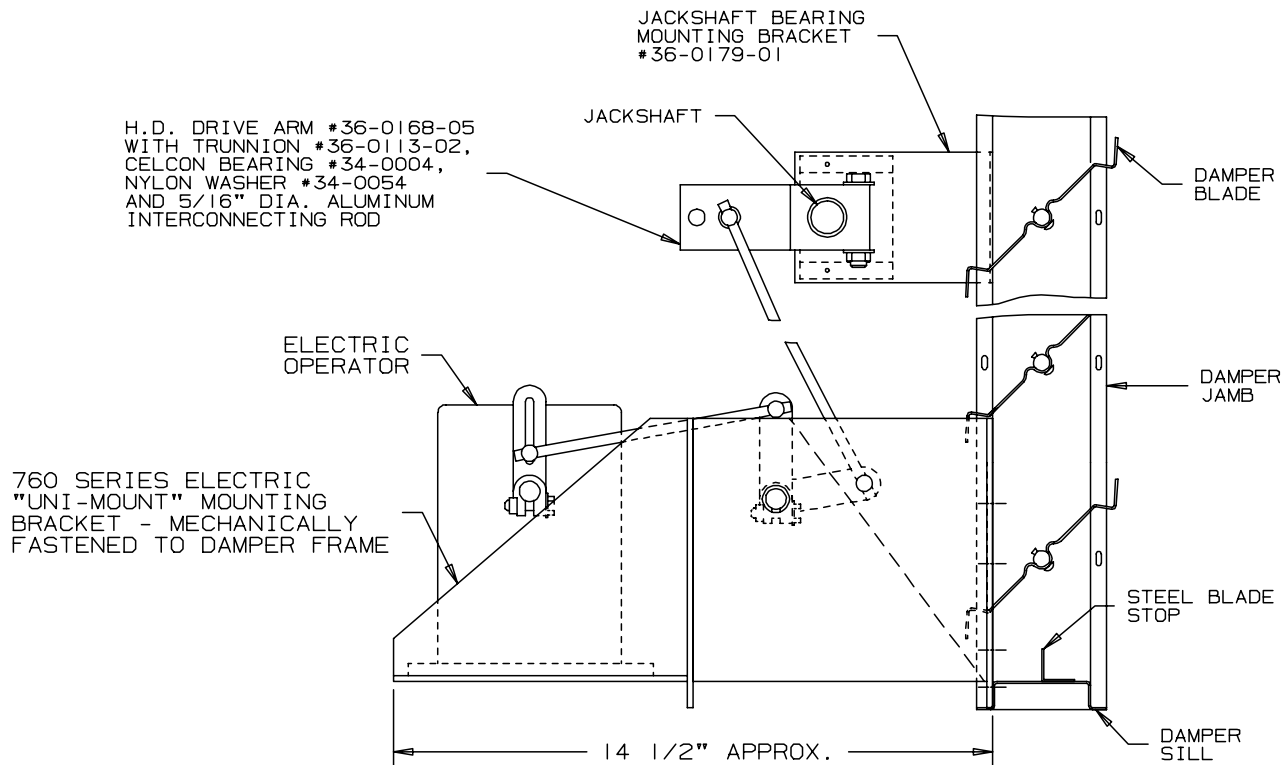

DETAIL # 27

OPERATOR MOUNTING DETAILS

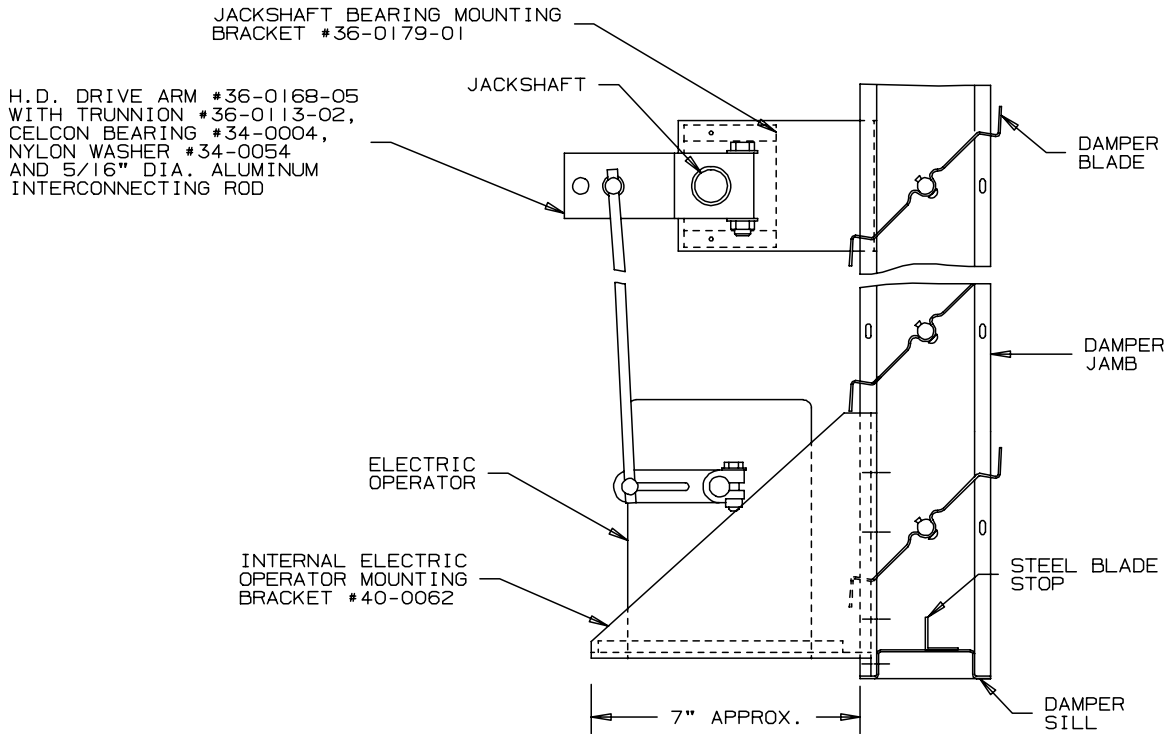

DETAIL # 28

LINKAGE DETAILS

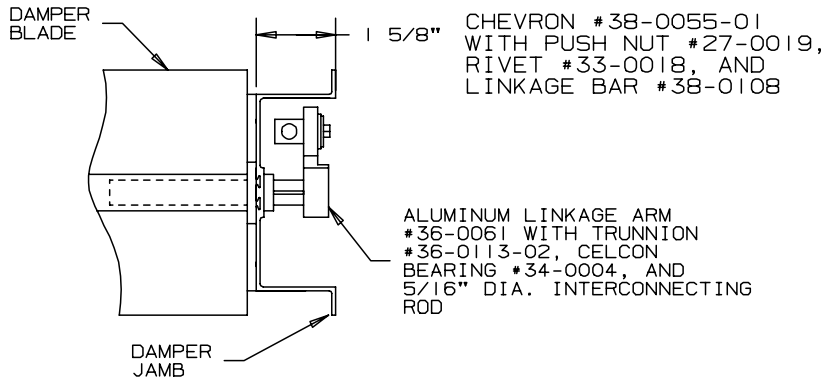

DETAIL # 29

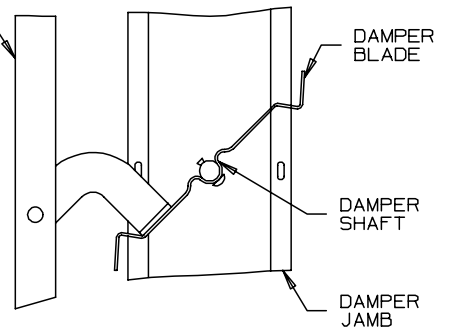

DETAIL # 31

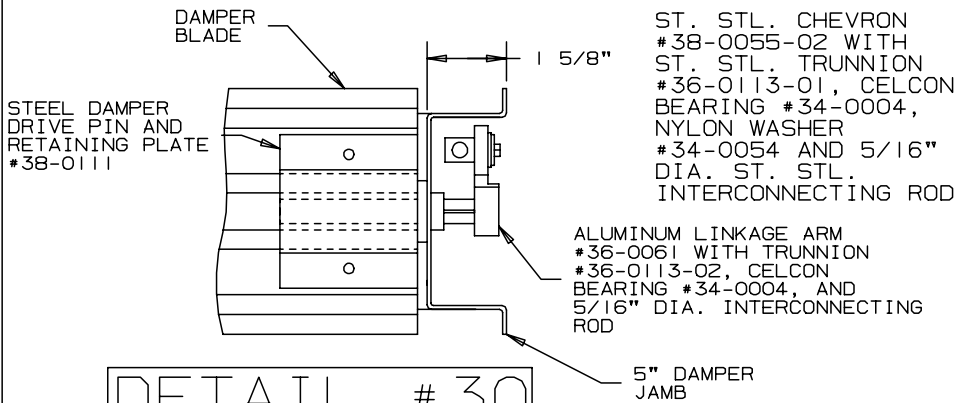

DETAIL # 30

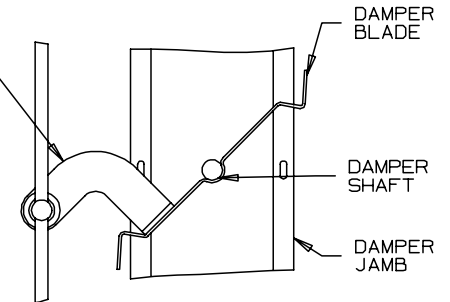

DETAIL # 32