

KN-16 - Dual Fuel

Category II or Category IV Appliance
(see Installation and Operation Manual for venting information)

CODE OPTIONS

| | |
|-------|----------|
| CSD-1 | STANDARD |
|-------|----------|

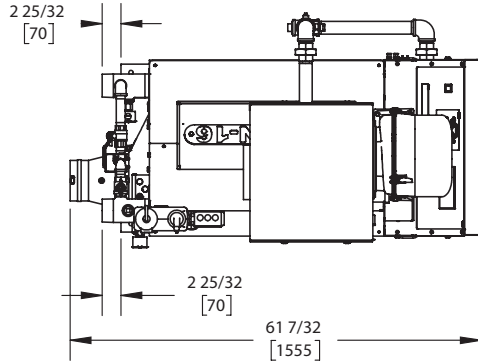

TOP VIEW

ASUB-29_D

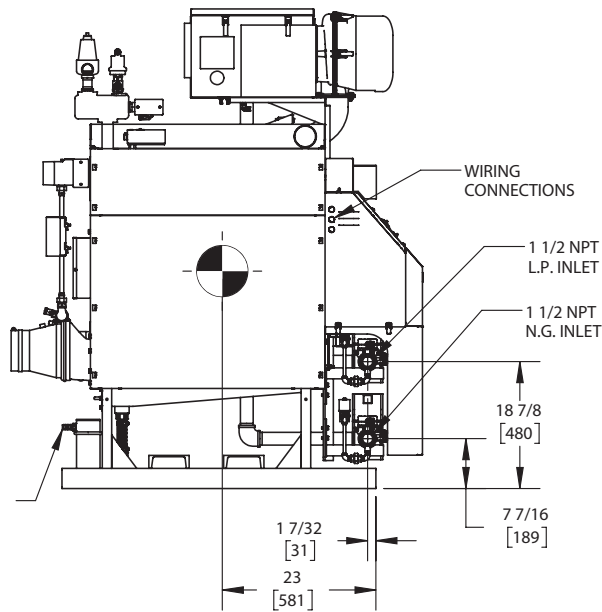

SIDE VIEW

ASUB-29_D

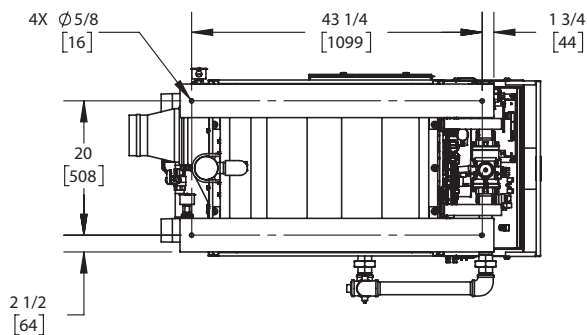

BOTTOM VIEW

ASUB-29_D

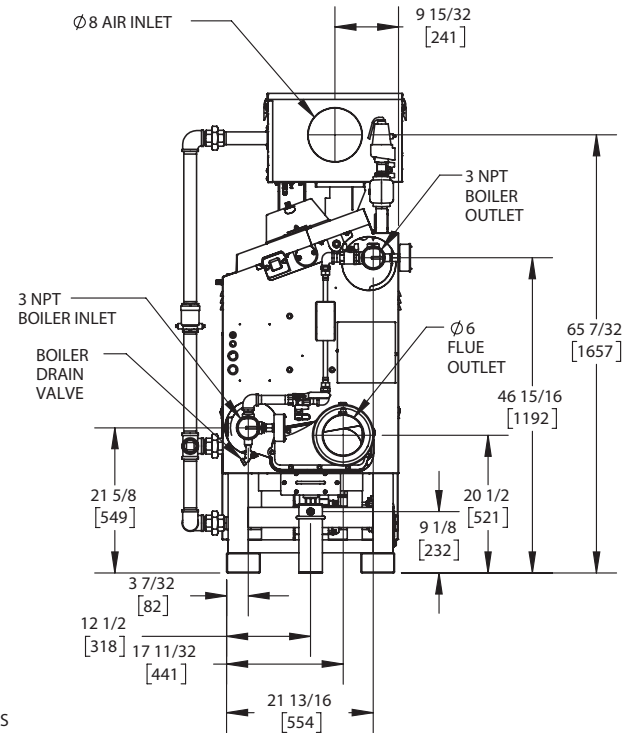

REAR VIEW

ASUB-29_D

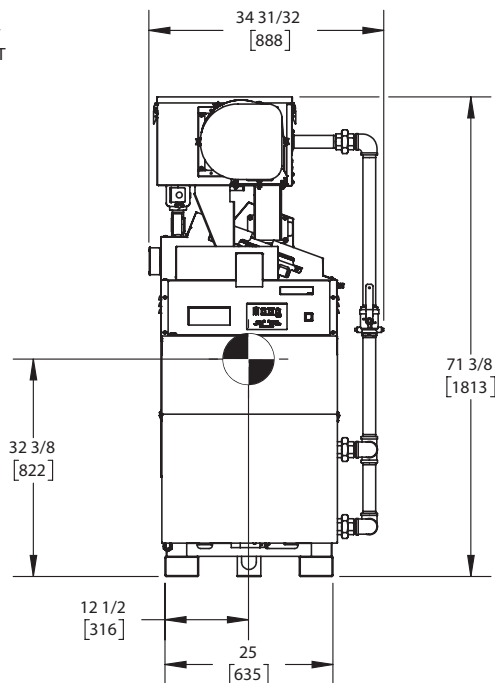

FRONT VIEW

ASUB-29_D

NOTES:

1. SYMBOL INDICATES CENTER OF GRAVITY.
2. DIMENSIONS ARE NOMINAL AND SUBJECT TO MANUFACTURING VARIATION AND SHOULD NOT BE USED FOR "ROUGHING IN".
3. ALL DIMENSIONS ARE INCHES [mm].



A.G.A. CERTIFIED RATINGS & CAPACITIES

| | | | |
|--------------------------------|---------------------------------|-----------------------------------|----------------------|
| Fuel Type | Natural/LP Gas | Boiler FLA | 13.1 A* |
| Input BTU/hr. | 1600 MBH / 469 KW | Min. Gas Pressure Required | 3" W.C. |
| Output BTU/hr. | 1440 MBH / 422 KW | Max. Gas Pressure Allowed | 14" W.C. |
| Boiler HP | 43.0 | Water Volume | 17.9 gal. |
| Electrical Requirements | 230VAC/60 hz/1PH (with neutral) | Operating Weight | 2360 lbs. / 1070 kg. |
| SCCR Rating | 5kA | | |

BOILER TRIM & CONTROLS

| | | | |
|--------------------------|-------------------|----------------------------|----------------------|
| Main Gas Valve | Dungs MBC | Air Switch | Huba |
| Firing Valve | 1-1/2" Apollo | Flow Sensor | SIKA |
| Ignition Control | Honeywell RM7895C | Blocked Flue Switch | Cleveland NS2 |
| Operating Control | HeatNet® | Blower Motor | Ametek |
| High Limit | Honeywell L4006E | L.W.C.O. | 800 |
| Main Ball Valve | 1-1/2" Apollo | Relief Valve | 30, 50, 75 & 100 PSI |
| Pilot Cock | 1/4" Conbraco | Pilot Regulator | Maxitrol RV12LT |

A.S.M.E.

| | | | |
|--|-----------------------------|--------------------|-----------------|
| ASME Sect IV Fire Side Htg Surface | 54.43 Sq. Ft. / 5.06 Sq. M. | Design Data | 100 PSI & 250°F |
| ASME Sect IV Water Side Htg Surface | 56.86 Sq. Ft. / 5.28 Sq. M. | | |
| CV. GPM (1PSID) | 140 | | |

*Add circulator amps.

TEMPERATURE RISE / PRESSURE DROP (Based on Full Input)

| 20°F / 11.1°C | | | | 40°F / 22.2°C | | | | 60°F / 33.3°C | | | | 80°F / 44.4°C | | | | 100°F / 55.5°C | | | |
|---------------|------|---------------|------|---------------|------|---------------|------|---------------|------|---------------|-----|---------------|------|---------------|-----|----------------|------|---------------|-----|
| Flow Rate | | Pressure Drop | | Flow Rate | | Pressure Drop | | Flow Rate | | Pressure Drop | | Flow Rate | | Pressure Drop | | Flow Rate | | Pressure Drop | |
| GPM | L/s | Ft | kPa | GPM | L/s | Ft | kPa | GPM | L/s | Ft | kPa | GPM | L/s | Ft | kPa | GPM | L/s | Ft | kPa |
| 144.1 | 9.10 | 2.44 | 7.30 | 72.0 | 4.50 | .61 | 1.80 | 48.0 | 3.00 | .27 | .80 | 36.0 | 2.30 | .15 | .50 | 28.8 | 1.80 | .10 | .30 |

| Flow GPM | | Temp. Rise** (°F) | | Vent Length (Equiv. Ft.) | | Air Inlet Length (Equiv. Ft.) | |
|----------|-------|-------------------|-----|--------------------------|-----|-------------------------------|-----|
| Min | Max | Min | Max | Min | Max | Min | Max |
| 28.8 | 144.1 | 20 | 100 | 6 | 120 | 0 | 120 |

**Min/Max delta t reflects boiler operation at full input. For applications requiring operation above/below these parameters please consult factory.

| | |
|---------------------|-------|
| REP FIRM | _____ |
| SUBMITTED BY | _____ |
| JOB NAME | _____ |
| ARCHITECT | _____ |
| ENGINEER | _____ |
| CONTRACTOR | _____ |
| DATE | _____ |

KN-16 - Dual Fuel

Category II or Category IV Appliance
(see Installation and Operation Manual for venting information)



A Division of Mestek, Inc.
Westfield, MA 01085
(413) 564-5515