

KICKSPACE HEATER

INSTALLATION INSTRUCTIONS

ATTENTION: READ THESE INSTRUCTIONS CAREFULLY BEFORE ATTEMPTING TO INSTALL, OPERATE, OR SERVICE THE KICKSPACE HEATERS! RETAIN THESE INSTRUCTIONS FOR FUTURE REFERENCE.



INSPECT THE SHIPMENT IMMEDIATELY WHEN RECEIVED TO DETERMINE IF ANY DAMAGE HAS OCCURRED DURING SHIPMENT.

PRIOR TO INSTALLATION, CHECK FOR ANY VISIBLE DAMAGE. MAKE CERTAIN THAT ANY LOOSE PARTICLES ARE REMOVED (ESPECIALLY IN THE BLOWER ASSEMBLY AREA).

SAFE TO USE WITH POTABLE WATER.

GENERAL DESCRIPTION

Kickspace heaters are for use with forced hot water residential heating systems and consist of a serpentine copper tube, aluminum finned heating element, with an electric motor and blower of unique cross flow design. Their purpose is to deliver a comfortable stream of warmed air, at or near floor level, and their construction is extremely compact so minimum space is required for installation. This unit is primarily used in horizontal floor installation, for example: under a kitchen counter cabinet, or bathroom sink enclosure. Although it is also available for verticle mounting, fully recessed in the wall studs, with the air discharged upward through a flush mounted, louvered front panel. All types have heating elements with 1/2" nominal (5/8 O.D.) copper tube connections, and 115V. electric blower motor, interwired with a 120°F (49°C) reverse acting aquastat that prevents operation until hot water is circulating. These units are **NOT** intended to be used on one or two pipe steam systems. See bottom of page 7. For gravity fed systems, it is recommended that a separate circulator pump be installed for the kickspace heater.

INSTALLATION (FLOOR MOUNT)

1. Select a location under the bottom shelf of a cabinet that meets the minimum dimensions shown in Fig. 1.
2. **CUT AN ACCESS PANEL THROUGH THE BOTTOM OF THE CABINET AT THIS LOCATION, LARGE ENOUGH FOR INSTALLATION AND SERVICE. IT IS RECOMMENDED THAT THIS ACCESS PANEL BE CONSTRUCTED SO ANNUAL CLEANING OF THE BLOWER FAN AND COIL FINS CAN BE EASILY ACCESSIBLE.**
3. **At this location, center and cut an opening in the toe-space riser 4" high x 11" long (Model 48) (See Figure 1) or 4" high x 18" long (Model 88) (See Figure 2).**
4. **Set the heater in the space at finished floor level** and check piping and wiring locations. The air outlet should be facing but not extending beyond the toe-space riser at the opening. The air outlet should also be located at the bottom portion of the 4" toe-space riser (See figure 1) at finished floor level. Make sure the switch is accessible through the grille opening. The front of the unit should fit flush to the inside of the toe space riser.
6. If using the "Easy Connect" Flexible Hose Connection Kit, see those installation instructions.
7. Next, prepare the heating element for pipe connections (this procedure will also pertain to floor and wall models). Remove the screws from the electric conn. box. Unsnap (pull) the thermostat clamp from the return copper U-bend. Holding down the top cover, remove the 4 element cover screws. Carefully remove this top cover noting the position of the element and the neoprene side pad. Lift out the element for soldering and fittings. Both ends are sized to accept 1/2" solder fittings. (Note required fittings for one pipe and two pipe systems on page 6).
8. Replace the heating element in the bottom cover in the proper position. Place the neoprene side pad in position and replace the top cover using the 4 screws. Tighten enough to keep the element in place between the covers. **DO NOT OVER-TIGHTEN!**
9. Place the heater under the cabinet and connect the piping and wiring. **Make sure unit & outlet are free of any dirt or debris prior to start up.** Turn on the system, purge of air, check blower operation and check for any possible leaks in the piping (run for 2 hrs. minimum). It should then be screwed to the floor through the four resilient mounting feet (2 inside electrical box and 2 external). Do not over-tighten screws. Secure top of electrical box.



260 NORTH ELM ST., WESTFIELD, MA 01085
 TEL: (413) 568-9571
 www.mestek.com

MODEL 48
Figure 1

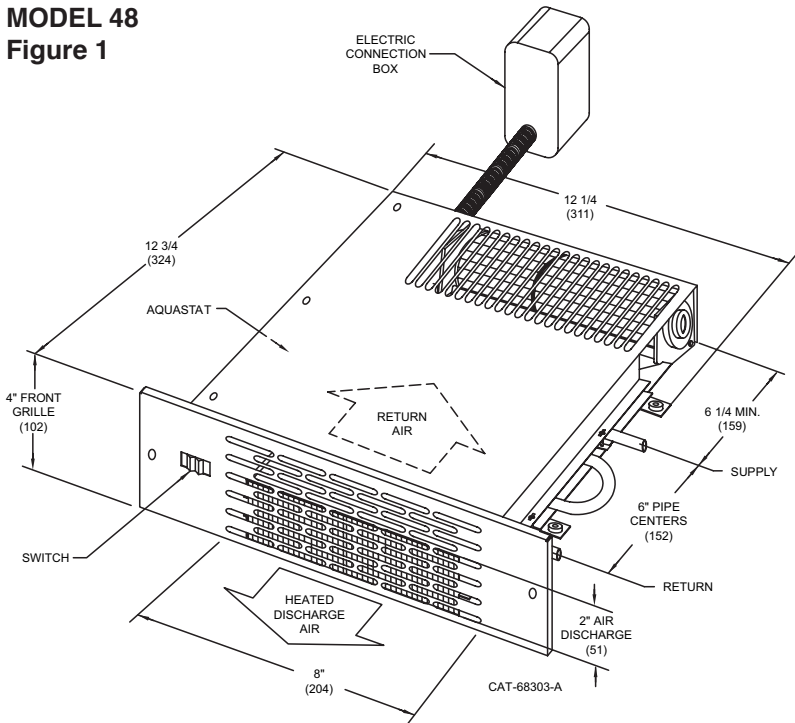

MODEL 88
Figure 2

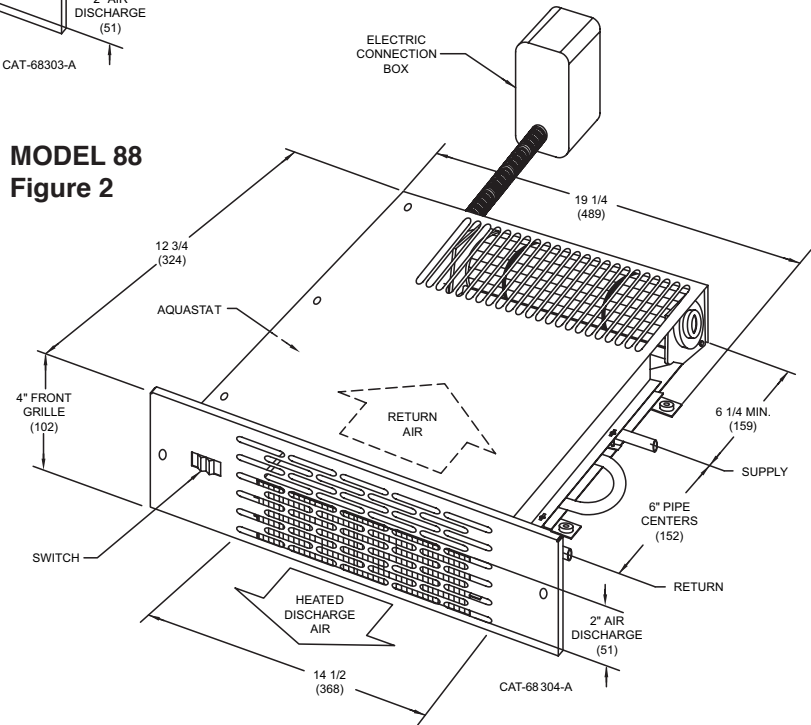

Dimensions shown
in English and metric ().

MODEL 48
KICKSPACE HEATER

(BTUH Ratings Based On 65°F Entering Air)

Fan Speed	GPM	160°F	170°F	180°F	190°F	200°F	210°F
Low	1	2666	2811	2956	3101	3246	3391
High	1	4143	4484	4825	5166	5507	5848

LOW SPEED AIR FLOW: 30 CFM
HIGH SPEED AIR FLOW: 53 CFM
VOLTAGE: 110-120V AC; 1 PH 60 HZ
FRICTION LOSS: 0.11 FT @ 1 GPH
WATER CONNECTIONS: 1/2" NOMINAL COPPER PIPE
THERMOSTATIC FAN SWITCH: BI-METAL TYPE;
CONTACTS CLOSE @ 120°F +/-5°F; 15°F DIFFERENTIAL

MODEL 88
KICKSPACE HEATER

(BTUH Ratings Based On 65°F Entering Air)

Fan Speed	GPM	160°F	170°F	180°F	190°F	200°F	210°F
Low	1	4600	4995	5390	5785	6180	6575
High	1	6900	7875	8850	9825	10,800	11,775

LOW SPEED AIR FLOW: 60 CFM
HIGH SPEED AIR FLOW: 103 CFM
VOLTAGE: 110-120V AC; 1 PH 60 HZ
FRICTION LOSS: 0.18 FT @ 1 GPH
WATER CONNECTIONS: 1/2" NOMINAL COPPER PIPE
THERMOSTATIC FAN SWITCH: BI-METAL TYPE;
CONTACTS CLOSE @ 120°F +/-5°F; 15°F DIFFERENTIAL

INSTALLATION OF KICKSPACE WALL MODELS

Figures 3 and 5 show exploded views of the wall models. Figure 4 shows the "IW" type mounted in a wall with an air outlet at the top of the unit. Figure 6 shows the wall mounted "EW". The louvers of the front panel will direct the air flow as shown. Use the following procedures for installation:

VERTICAL IN WALL INSTALLATION

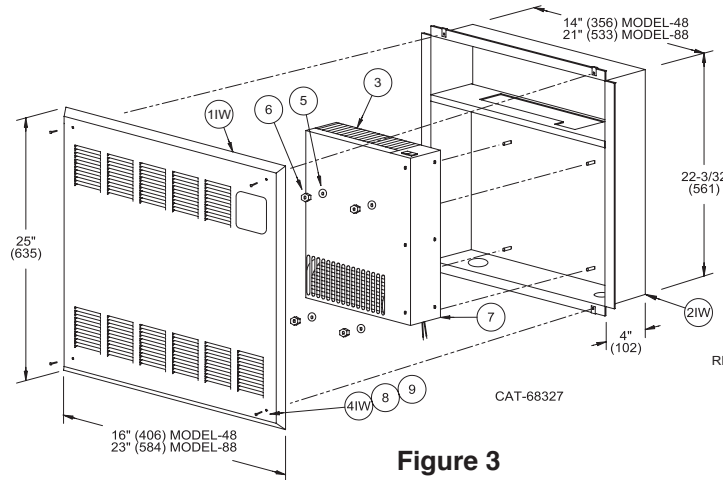

Figure 3

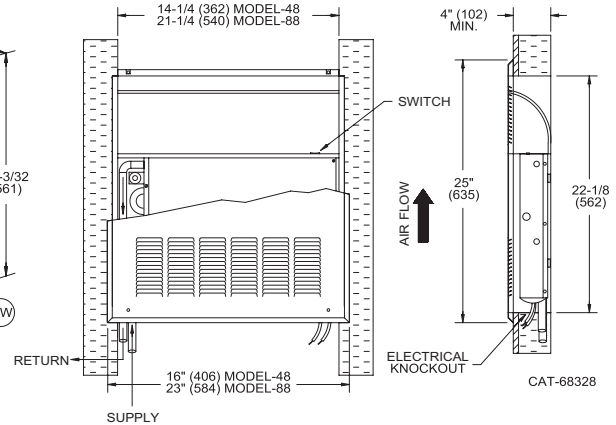

Figure 4

VERTICAL FIGURE 3 PARTS LIST

- | | |
|--------------------------------|---|
| 1IW. FRONT PANEL ASS'Y | 6. FLANGED NUTS |
| 2IW. BACK RECESSED PANEL ASS'Y | 7. FAN/COIL UNIT ELECTRICAL CONTROL BOX COVER |
| 3. FAN/COIL UNIT (FCU) | 8. WASHERS (PLASTIC) |
| 4IW. FRONT PANEL MTG. SCREWS | 9. SNAP-CAP (PLASTIC) |
| 5. LOCKWASHERS | |

PART #3 AND #7 (FAN/COIL UNIT) WILL BE SHIPPED IN IT'S OWN CARTON. ALL REMAINING PARTS ARE INCLUDED IN A SEPERATE CARTON.

TYPE "IW":

1. Frame an opening between wall studding as shown in Figure 4. Model 48 will fit between studs that are on 16" centers. Model 88 will require a small amount of framing to suit the mounting. A 7/8" diameter hole is provided at the bottom of the cabinet interior to provide entrances for electrical connections, and a 7/8" diameter knockout is provided at the rear of the motor in the electrical control box. A 2-1/2" diameter hole is provided at the bottom of the cabinet interior to provide an entrance for piping connections. Cut horizontal framing to clear, as necessary.
2. After removing the front panel mounting screws (Item 4IW), remove the front louvered panel (Item 1IW). Notice the direction of the louvers (see the air flow direction label on inside front label).
3. Nail the recessed cabinet (Item 2IW) to the framed opening at both sides.
4. Mount the Fan/Coil Unit (Item 3) to the recessed back panel, remove the electrical control box cover from fan/coil unit. Secure the fan/coil unit in place using Items 5 & 6 as shown in Figure 3. Do not over tighten.
5. Remove the heating element from the fan/coil unit (Item 3) following the procedure described in the installation of horizontal, step 6. Hold this element and fittings temporarily in place in the recessed cabinet before soldering to check for clearance and length of tubing required.
6. After piping connections have been made, return the element to the cabinet as described in horizontal installation, step 8.
7. Electrical connections for the wall units are to be made as shown on page 5.
8. Make final piping and electrical connections (see pages 5 & 6) to the system in the cabinet. Secure in place the electrical control box cover. Turn on the system, purge of air, check blower operation, and check for any possible leaks in the piping.
9. Replace front panel (Item 1IW), place washers (Items 8) in required positions, screw through holes and tighten.
10. Place snap-cap® (Item 9) over washer at angle. Push snap-cap® (Item 9) DOWN firmly until it engages with a snap.

VERTICAL EXTERNAL WALL INSTALLATION

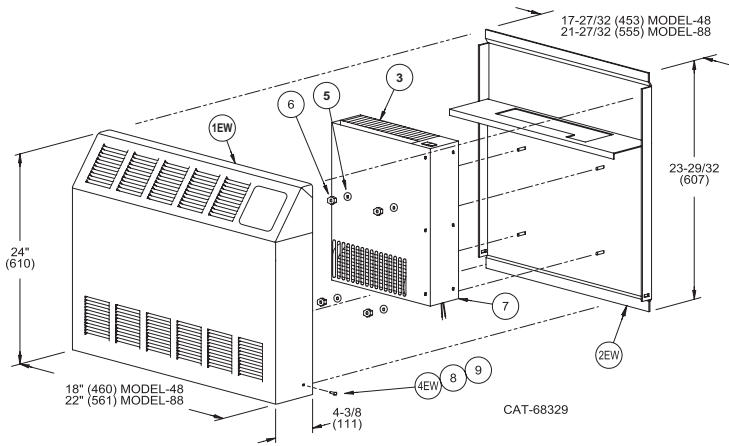

Figure 5

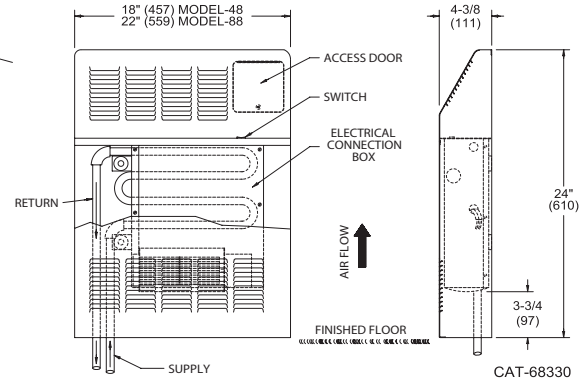

Figure 6

TYPE "EW"	1EW.	FRONT PANEL
FIGURE 5	2EW.	BACK PANEL
PARTS LIST	3.	FAN/COIL UNIT (FCU)
	4EW.	FRONT PANEL MTG. SCREWS
	5.	LOCKWASHERS
	6.	FLANGED NUTS
	7.	ELECTRICAL CONTROL BOX COVER
	8.	WASHERS (PLASTIC)
	9.	SNAP-CAP (PLASTIC)

PART #3 (FAN/COIL UNIT) WILL BE SHIPPED IN IT'S OWN CARTON. ALL REMAINING PARTS ARE INCLUDED IN A SEPERATE CARTON.

TYPE "EW":

1. Locate the heater at or near floor level, and plan for water and electrical services feed through the bottom of the enclosure. If over rough flooring, be sure to allow clearance above the finish that will not interfere with removal of the front panel. The back panel (Item 2EW) should be screwed or nailed securely to the wall.
2. Remove the front panel (Item 1EW) by removing the two screws at the bottom. Then pull the bottom away from the enclosure and lift the top from its hooked position. To replace the panel, press down firmly to engage it in the top channel and lock the two sides over the front edge of the enclosure at the clamps.
3. Mount the Fan/Coil Unit (Item 3) to the back recessed panel, remove the electrical control box cover from fan/coil unit. Secure the fan/coil unit in place using items 5 & 6 as shown in Figure 5. Do not over tighten.
4. Soldering may be done to the fan/coil unit (Item 3) with care within vertical enclosure, or the element may easily be removed, if so desired. Follow the same procedure as described in Horizontal Installation, step 6.
5. After the piping connections are made, return the element to the cabinet as described in horizontal Installation, step 7. Removal and replacement will be simpler if done in a horizontal position before the enclosure is secured to the wall.
6. Electrical connections for the wall units are to be made as indicated on page 5.
7. Make final piping and electrical connections (see pages 5 & 6) to the system in the cabinet. Turn on the system, purge of air, check blower operation, and check for any possible leaks in the piping.
8. Replace front panel (Item 1EW), place washers (Item 8) in required positions, screw through holes and tighten.
9. Place snap-cap® (Item 9) over washer at angle. Push snap-cap® (Item 9) down firmly until it engages with a snap.

ELECTRICAL CONNECTIONS

CAUTION! For Supply Connections, use wires suitable for at least 194° F (90° C).

All electrical connections must conform to local and national codes.

A shaded pole motor is used to drive the Hideavector3 blower on 115 -120 V. 60 hz. Since current drain is very small, wiring codes for short circuit protection only will apply. The motor is connected in series with a normally open aquastat in contact with the heating element. Therefore, the blower runs only when unit is sufficiently hot and the switch is in the "min" or "max" position (not "off"). A ground screw is supplied with all units.

Electrical connections are to be made to all units following the diagrams below. Choose the diagram that best suits your application.

Since the blower runs on all models only when the system circulator pumps hot water through the unit, simply connect it to the 115 V line. The blower then starts after a short warm-up, and stops a few minutes after the circulator shuts off (see Diagram 1).

Adding a line voltage type room thermostat will permit the setting of a maximum room temperature (see Diagram 2). This 'T' stat will only operate the fan/coil unit. If the circuit or system circulator is not running, the fan/coil unit will not operate.

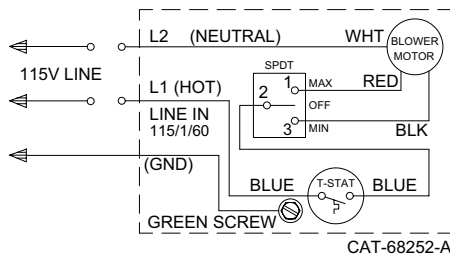

Diagram 1

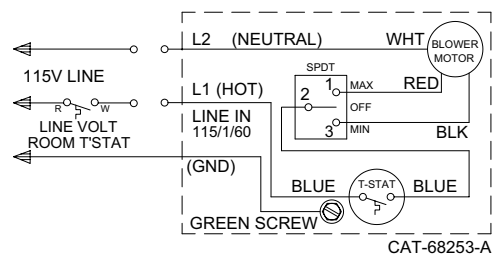

Diagram 2

Connection through a circulator or zone auxiliary switch may also be used to permit instant shutdown of the blower as the circulator stops (see Diagram 3).

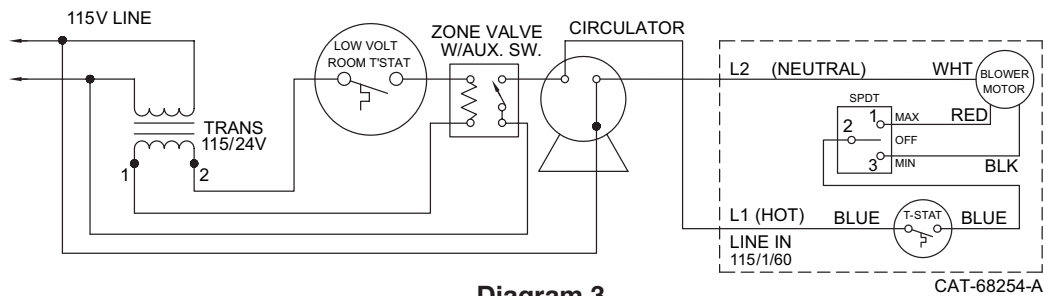

Diagram 3

MOTOR INFORMATION					
MODEL	AMP	WATT	RPM	HP	VOLTAGE
48	.50	30.7	3200	.034	115
88	.50	30.7	3200	.034	115



SYSTEM CONSIDERATIONS

Kickspace heaters should be connected only to circulating **hot water systems** where at least 1 gpm water flow is expected. They are essentially small unit heaters, and will work on one or two pipe systems, or in a series loop where pressure and temperature drop can be tolerated (see capacity charts and piping diagrams). These units are not designed for use with steam systems. See bottom paragraph on page 7. These units are not recommended to be used with a gravity flow system.

PIPING CHARTS

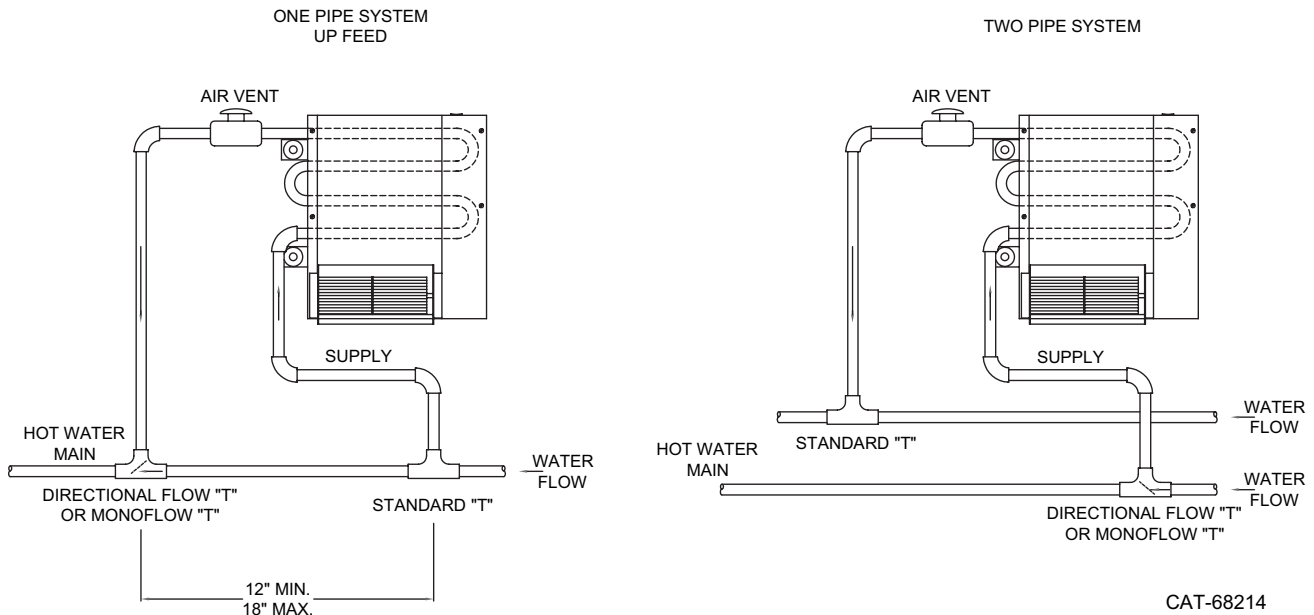

NOTE: In an up feed system, unit is located above hot water supply line. In a down feed system, unit is located below hot water supply line.

For one pipe system down feed, two directional flow tees should be used. They should be spaced 12 to 18 inches apart. The directional arrow on the directional flow 'T' at the return side should point towards the supply directional flow 'T'.

If directional flow (mono-flo) tee's are not available, an adjustable screw operated flow control or circuit setter can be placed between the two standard tee's in a one pipe system.

For consistent response of the reverse acting thermostat, and effective outlet air temperature, the average water temperature should not be below 120°F (49°C). Blower motor shuts off at 105°F (41°C) and will not operate until water temperature reaches 120°F (49°C).

If utilizing water temperature below 120°F (49°C), the blower will not operate with the self contained aquastat. An optional low temperature aquastat, 110° to 95°F (43° to 35°C) is available.

MAINTENANCE & SERVICE

Properly installed, the Kickspace heater should require very little attention. Since the heating element is carefully constructed and tested, and of non-ferrous materials, it should never require service. The cross-flow blower has been thoroughly engineered, with ball bearings for 10,000 hrs. bearing life expectancy. **As with any electrical rotating device, a yearly inspection and cleaning is recommended.** Wherever there is air movement, there will be some accumulation of dust and lint. In this case it will collect on the rotor blades and air passage of the unit. Regular cleaning with a vacuum cleaner tool is advised, with frequency determined by prevailing conditions. **Always make sure that the air grille is not blocked by foreign objects or materials.**

REPLACEMENT PARTS LIST

Description	Part No.	Model	
		48	88
Motor-Fan Assembly	BMK-02020-001	X	
	BMK-02020-002		X
Standard Aquastat Assembly (120° – 105°F)	J13-01353	X	X
Low Temp. Aquastat Assembly (110° – 95°F)	J17-55083	X	X
Heating Element	BMK-02017-001	X	
	BMK-02017-002		X
2 Speed Fan Switch	J11-02029-001	X	X
Outlet Grille w/ screws	HAV-25150	X	
	HAV-25250		X
Louvered Front Panel (Model IW only)	BMK-02172-001	X	
	BMK-02172-002		X
Louvered Front Panel (Model EW only)	BMF-02165-001	X	
	BMF-02165-002		X

ACCESSORIES

Description	Part No.	Model	
		48	88
Quick-Connect Hose Kit	HAV-HK-10	X	X
Speed Control Switch	HAV-SC	X	X

STEAM CONDENSATE DIAGRAM

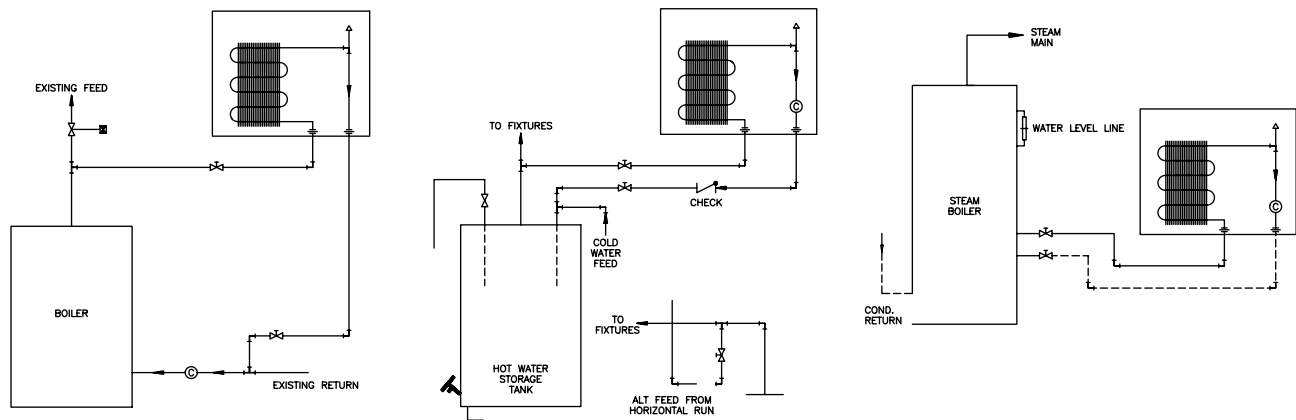

On a typical forced hot water system, connect return to inlet side of circulator and supply upstream of remotely operated valve. Unit may also be connected to mains of an existing loop system of sufficient capacity. Operation will be influenced by the system circulator and associated controls.

Installation of a pump and line voltage thermostat will provide the unit with its own “zone” control.

With the addition of a circulator pump, hot water storage tanks may be used (where codes permit) as a supply source if proper precautions are taken, and if relatively low water temperatures can be tolerated. Be sure tank can supply additional load of the Kickspace heater and 120°F water. Supply is taken from top of tank, and returns at the cold water inlet with a check valve. Do not return to bottom drain tapping.

Operation from steam boiler water is entirely possible as long as supply and return connection is installed below level of water line on a steam boiler. This installation requires an optional circulator pump and line voltage thermostat. Check local building codes.

5 YEAR LIMITED WARRANTY

MODELS 48 AND 88

The "Manufacturer" warrants to the original owner at the original installation site that the Models 48 and 88 heaters (the "Product") will be free from defects in material or workmanship for five (5) years from the date of shipment from the factory. If upon examination by the Manufacturer the Product is shown to have a defect in material or workmanship during the warranty period, the Manufacturer will repair or replace, at its option, that part of the Product which is shown to be defective.

This limited warranty does not apply:

- (a) if the Product has been subjected to misuse or neglect, has been accidentally or intentionally damaged, has not been installed, maintained or operated in accordance with the furnished written instructions, or has been altered or modified in any way.
- (b) to any expenses, including labor or material, incurred during removal or reinstallation of the defective Product or parts thereof.
- (c) to any workmanship of any installer of the Product.

This limited warranty is conditional upon:

- (a) shipment, to the Manufacturer, of that part of the Product thought to be defective. Goods can only be returned with prior written approval from the Manufacturer. All returns must be freight prepaid.
- (b) determination, in the reasonable opinion of the Manufacturer, that there exists a defect in material or workmanship.

Repair or replacement of any part under this Limited Warranty shall not extend the duration of the warranty with respect to such repaired or replaced part beyond the stated warranty period.

THIS LIMITED WARRANTY IS IN LIEU OF ALL OTHER WARRANTIES, EITHER EXPRESS OR IMPLIED, AND ALL SUCH OTHER WARRANTIES, INCLUDING WITHOUT LIMITATION IMPLIED WARRANTIES OF MERCHANTABILITY OR FITNESS FOR A PARTICULAR PURPOSE, ARE HEREBY DISCLAIMED AND EXCLUDED FROM THIS LIMITED WARRANTY. IN NO EVENT SHALL THE MANUFACTURER BE LIABLE IN ANY WAY FOR ANY CONSEQUENTIAL, SPECIAL, OR INCIDENTAL DAMAGES OF ANY NATURE WHATSOEVER, OR FOR ANY AMOUNTS IN EXCESS OF THE SELLING PRICE OF THE PRODUCT OR ANY PARTS THEREOF FOUND TO BE DEFECTIVE. THIS LIMITED WARRANTY GIVES THE ORIGINAL OWNER OF THE PRODUCT SPECIFIC LEGAL RIGHTS. YOU MAY ALSO HAVE OTHER RIGHTS WHICH MAY VARY BY EACH JURISDICTION.



260 NORTH ELM ST., WESTFIELD, MA 01085
TEL: (413) 568-9571
www.mestek.com