

Standard Construction and Materials

FRAME: .125" to .250" thick (nominal) extruded aluminum 6063-T52/T6 alloy.
Grille depth can be 2" to 6" deep.

BLADE: .125" to .250" thick (nominal) extruded aluminum 6063-T52/T6 alloy.
Blades can have 2" to 12" vertical and horizontal spacing and horizontal blade angle from 0° and 45°.

CONSTRUCTION: All welded construction.

FINISH: Factory mill.

Options
Finishes - Kynar, Baked Enamel, Clear and Color Anodize

Grille Screen Sizes

Min Panel	Max Single Panel
12"W x 12"H	60"W x 96"H (40 sq.ft.)

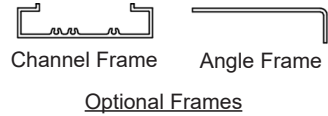
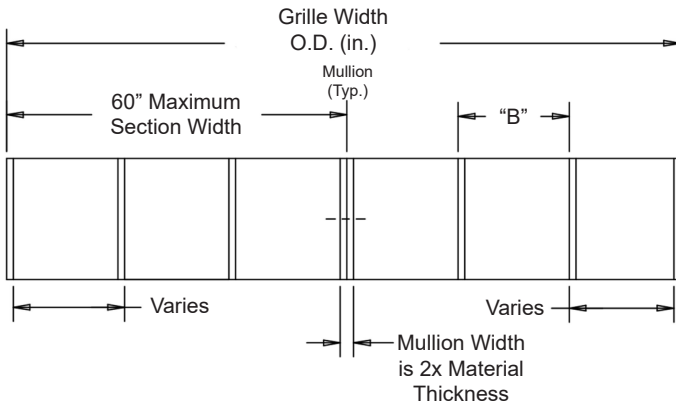
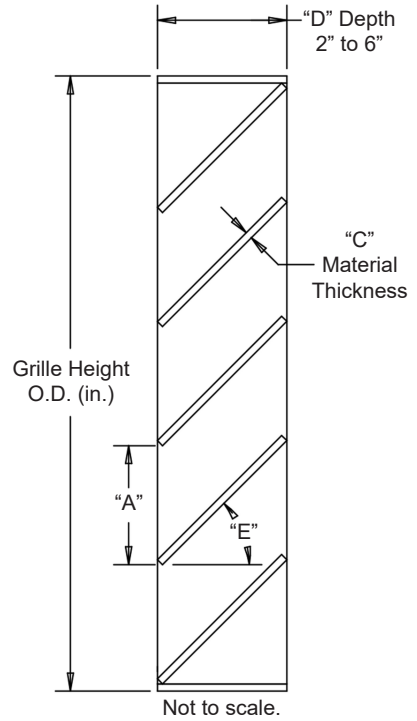

- "A" = 2" to 12" (Horizontal Blade Spacing)
- "B" = 2" to 12" (Vertical Blade Spacing)
- "C" = .125" to .250" (Material Thickness)
- "D" = 2" to 6" (Grille Depth)
- "E" = 0° to 45° (Blade Angle)

Item #	Qty	Horizontal	Vertical	Grille Depth				
		Blade Spacing			Material Thickness	Blade Angle		
Arch. / Eng. :				EDR:	ECN:	Job:		
Contractor:								
Project:				Date:	DWN:	DWG:		

In the interest of product development, Cesco Products reserves the right to make changes without notice.



450 Riverside Dr • Wyalusing PA, 18853
Phone: 570-746-1888 • Fax: 570-746-9286
www.cescoproducts.com