

INSTALLATION AND SERVICE MANUAL
VERTICAL COMBUSTION AIR INLET KITS
 CATEGORY III VENTING FOR SEPARATED COMBUSTION
 TUBULAR GAS FIRED UNIT HEATERS

USE 5 INCH KIT FOR UNITS WITH CAPACITIES 100,000 TO 250,000 BTU/HR
USE 6 INCH KIT FOR UNITS WITH CAPACITIES 300,000 TO 400,000 BTU/HR
 Supplement to unit installation instructions – STPIM, STBII, CVTPP or CVTBL

▲ WARNING Improper installation, adjustment, alteration, service or maintenance can cause property damage, injury or death. Read this supplement and the unit heater installation, operating and maintenance instructions thoroughly before installing or servicing this equipment.



This Combustion Air Inlet Kit utilizes one 5 or 6 inch termination in which both the discharge flue gas and the combustion air inlet pass.

The location of the vent terminal must be in accordance with the National Fuel Code ANSI Z223.1 (NFPA 54) in the U.S. or the Natural Gas Installation Code CSA-B149.1 or the Propane Gas Installation Code CSA-B149.2 in Canada. Minimum clearances are shown in Table 1.

KIT CONTENTS:

Figure 1a – 5 Inch Combustion Air Inlet Kit

- #1 – Part No. 11J37R02222-002
(1) Flue Vent Terminal
- #2 – Part No. 11507R08560-DBL
(1) Combustion Air Inlet Box Assembly (see Figure 2a for dimensional data)
- #3 – Part No. 11J37R08964-DBL
(1) Air Inlet Vent Cap
- #4 – Part No. 11507R08568-DBL
(1) Deflector Disk*

- Also Included:
- (1) Part No. J30-09023
Installation Instructions
 - (1) Part No. 11H03R03612-002
Tube of High Temp Silicone Sealant
 - (3) Part No. 11H03R09471-005
Gasket, O-ring – 5"

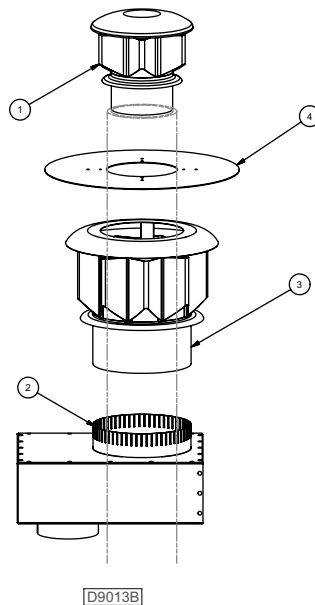
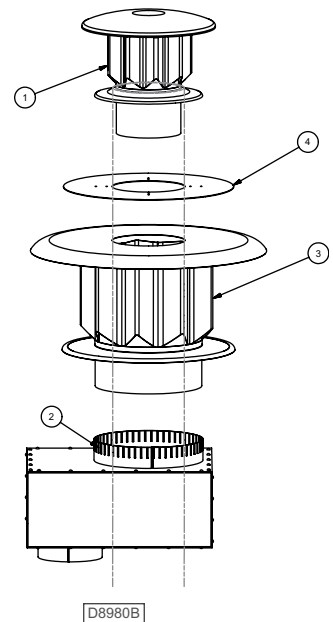

Figure 1b – 6 Inch Combustion Air Inlet Kit

- #1 – Part No. 11J37R02222-003
(1) Flue Vent Terminal
- #2 – Part No. 11507R08951-DBL
(1) Combustion Air Inlet Box Assembly (see Figure 2b for dimensional data)
- #3 – Part No. 11J37R08963-DBL
(1) Air Inlet Vent Cap
- #4 – Part No. 11507R09011-DBL
(1) Deflector Disk*

- Also Included:
- (1) Part No. J30-09023
Installation Instructions
 - (1) Part No. 11H03R03612-002
Tube of High Temp Silicone Sealant
 - (3) Part No. 11H03R09471-006
Gasket, O-ring – 6"



*Deflector disk comes with brackets (11252-06692) and screws for installation.



DIMENSIONAL DATA

Figure 2a – 5 Inch Combustion Air Inlet Box Assembly

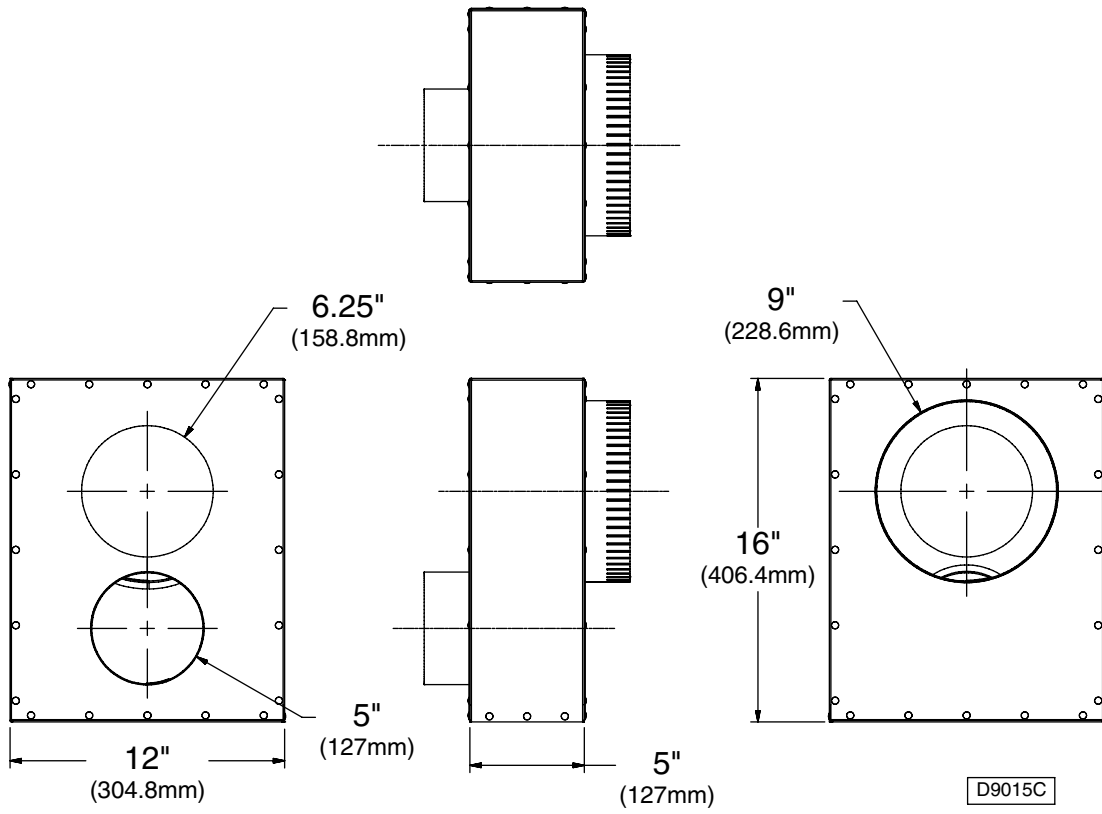
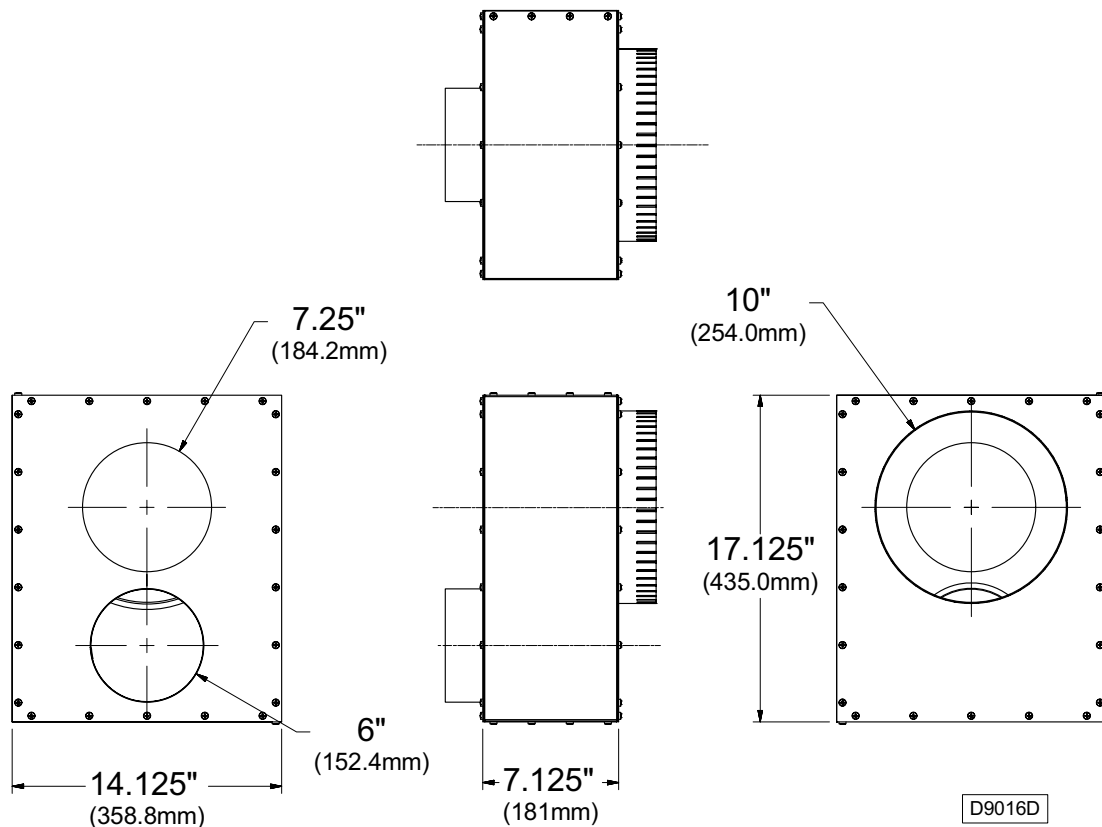

Figure 2b – 6 Inch Combustion Air Inlet Box Assembly



VENTING – GENERAL GUIDELINES

All unit heaters must be vented! All Venting installations shall be in accordance with the latest edition of Part 7, Venting of Equipment of the National Fuel Gas Code, ANSI Z223.1 (NFPA 54), or applicable provisions of local building codes. Refer to notes* below for Canadian installations.

▲ WARNING CARBON MONOXIDE! Your venting system must not be blocked by any snow, snow drifts, or any foreign matter. Inspect your venting system to ensure adequate ventilation exists at all times! Failure to heed these warnings could result in Carbon Monoxide Poisoning (symptoms include grogginess, lethargy, inappropriate tiredness, or flu-like symptoms).

When an existing heater is removed or replaced in venting system, the venting system may not be properly sized to vent the attached appliances. An improperly sized vent system can cause formulation of condensate or leakage or spillage of flue gases.

The following steps shall be followed with each appliance connected to the venting system placed in operation, while any other appliances connected to the venting system are not in operation:

1. Seal any unused openings in the venting system.
2. Inspect the venting system for proper size and horizontal pitch, as required in the National Fuel Gas Code, ANSI Z223.1 (NFPA 54) and these instructions. Determine that there is no blockage or restriction, leakage, corrosion and other deficiencies, which could cause an unsafe condition.
3. In so far as practical, close all building doors and windows and all doors between the space in which the appliance(s) connected to the venting system are located and other spaces of the building. Turn on clothes dryers and any exhaust fans, such as range hoods and bathroom exhausts, so they shall operate at maximum speed. Do not operate a summer exhaust fan. Close fireplace damper.

4. Follow the lighting instructions. Place the appliance being inspected in operation. Adjust thermostat so that the appliance will operate continuously.
5. After it has been determined that each appliance connected to the venting system properly vents when tested as outline above, return doors, windows, exhaust fans, fi replace dampers, and any other gas-burning appliance to their previous condition of use.
6. If improper venting is observed during any of the above tests, the venting system must be corrected immediately so that the system conforms with the National Fuel Gas Code, ANSI Z223.1 (NFPA 54). When resizing any portion of the venting system, the venting system should be resized to approach the minimum size as determined using the appropriate tables in Appendix G of the National Fuel Gas Code, ANSI Z223.1 (NFPA 54).

The unit heater shall be connected to a factory built chimney or vent complying with a recognized standard, or a masonry or concrete chimney lined with a lining material acceptable to the authority having jurisdiction.

Venting into an unlined masonry chimney is prohibited.

ADDITIONAL REQUIREMENTS FOR CANADIAN INSTALLATIONS

*The following instructions apply to Canadian installations in addition to installation and operating instructions.

1. Installation must conform with local building codes, or in the absence of local codes, with current CSA-B149.1, Installation Codes for Natural Gas Burning Appliances and Equipment, or CSA-B149.2, Installation Codes for Propane Gas Burning Appliances and Equipment.
2. Any reference to U.S. standards or codes in these instructions are to be ignored and the applicable Canadian standards or codes applied.

VENTING – GENERAL GUIDELINES *(continued)*

Do not damper or add heat recovery devices to the flue piping. Failure to open such a damper prior to operating the gas unit heater will result in the spillage of flue gas into the occupied space.

Avoid installing units in areas under negative pressure. When required, a flue vent fan should be installed in accordance with the instructions included with the fan.

Vent connectors serving Category I and Category II heaters shall not be connected into any portion of mechanical draft systems operating under positive vent pressure.

Maintain 1-inch (25.4mm) clearance between the vent pipe and combustible materials.

NOTICE: When using double wall vent pipe, O-ring gaskets are not required and should be discarded. When using single wall vent pipe, one O-ring should be inserted in each of the pipe openings in the Air Inlet Vent Cap, Deflector Disk and the top of the Combustion Air Inlet Box Assembly.

ANSI now organizes vented appliances into four categories:

Venting Categories

	Non Condensing	Condensing
Negative Vent Pressure	I	II
Positive Vent Pressure	III	IV

Category I

Includes non-condensing appliances with negative vent pressure, like the traditional atmospheric unit heater.

Category II

Groups condensing appliances with negative vent pressure.

Category III

Appliances are non-condensing and operate with a positive vent pressure.

Category IV

Covers condensing appliances with positive vent pressure.

NOTICE: Category II and IV do not apply to equipment specified within this manual.

Table 1

Vent Systems Termination Clearance Requirements

Structure/Object	Minimum Clearances for Termination Locations	
	USA	CANADA
Door, window or gravity vent inlet or combustion air inlet for other appliances	4 ft. below 4 ft. horizontally 1 ft. above	1 ft. (0.3m) for 100,000 BTUH input or less. 3 ft. (0.9m) for input exceeding 100,000 BTUH
Forced air inlet within 10 ft.	3 ft. above	6 ft. (1.8m)
Adjoining building or parapet	10 ft.	10 ft. (3.04m)
Adjacent public walkways	7 ft. above grade	7 ft. (2.1m) above grade
Electric, gas meters & regulators	4 ft. horizontal	3 ft. (0.9m) horizontally from meter/regulator assembly. 6 ft. (1.8m), any direction, from a gas service regulator vent outlet
Above grade level*	1 ft.	1 ft. (0.3m)

* Minimum above maximum snow depth, or per local code, whichever is greatest.

INSTALLATION

VERTICAL TERMINATION, 5 INCH KIT FOR USE WITH 100-250 MBH UNITS ONLY

Select a location on the roof for vent terminal ensuring adequate space inside for combustion air inlet box. Vent terminal must be at least 10 feet (3.04m) from any wall or adjoining building. See Table 1 and Figure 3a.

Cut hole through the roof for 9 inch (229mm) combustion air pipe. The combustion air inlet box is to be suspended from the underside of the roof using suitable brackets (field supplied). Before mounting vent box, cut a length of 9 inch pipe so that dimension "A" Figure 4, Step 1 is equal to the roof thickness plus 18 inches (457mm) or the roof thickness plus the expected snow depth, whichever is greater. Fasten the 9 inch pipe to the combustion air inlet on the combustion air inlet box. Seal the joint and fasten with sheet metal screws.

Insert the pipe through the roof and fasten vent box into place (See Figure 4, Step 2). Flash and/or caulk 9 inch pipe to roof (See Figure 4, Step 3). Install the inlet air cap and fasten with sheet metal screws.

Insert a length of 5 inch UL 1738 listed vent pipe in the direction of flow pointing upward through the air inlet vent cap. Vent pipe should be inserted into the combustion air inlet box so that the pipe extends a minimum of 6 inches (152mm) below the vent box for connection purposes. This will allow room to seal the flue pipe.

Secure the UL 1738 listed pipe in position with 3 small, evenly spaced sheet metal screws. With high temperature silicone, seal the space between the UL 1738 listed pipe and the combustion air inlet box as well as the space between the UL 1738 listed pipe and the air inlet terminal (See Figure 4, Step 4).

Install the deflector disk on the UL 1738 listed vent pipe at least 12 inches (305mm) above the air inlet terminal and fasten with screws. Seal the joint between deflector disk and pipe with high temperature silicone.

Install the vent cap to the UL 1738 listed pipe using sheet metal screws. Ensure there is a minimum of 12 inches (305mm) between the bottom of the flue vent terminal and the top of the air inlet vent cap (See Figure 3a and Figure 4, Step 4). Connect flue pipe and combustion air pipe from the combustion air inlet box to the unit, following instructions in the manual provided with the unit and Combustion Air and Exhaust Venting instructions on pages 7 and 8.

▲ WARNING Never use pipe other than 5 inch diameter. Never use PVC, ABS or any other non-metallic pipe for venting! To do so may result in serious damage to the unit and or severe personal injury or death!

Figure 3a – Vertical 5 Inch Combustion Air Inlet Kit Installation

Note: Separated Combustion Blower Type Unit Shown

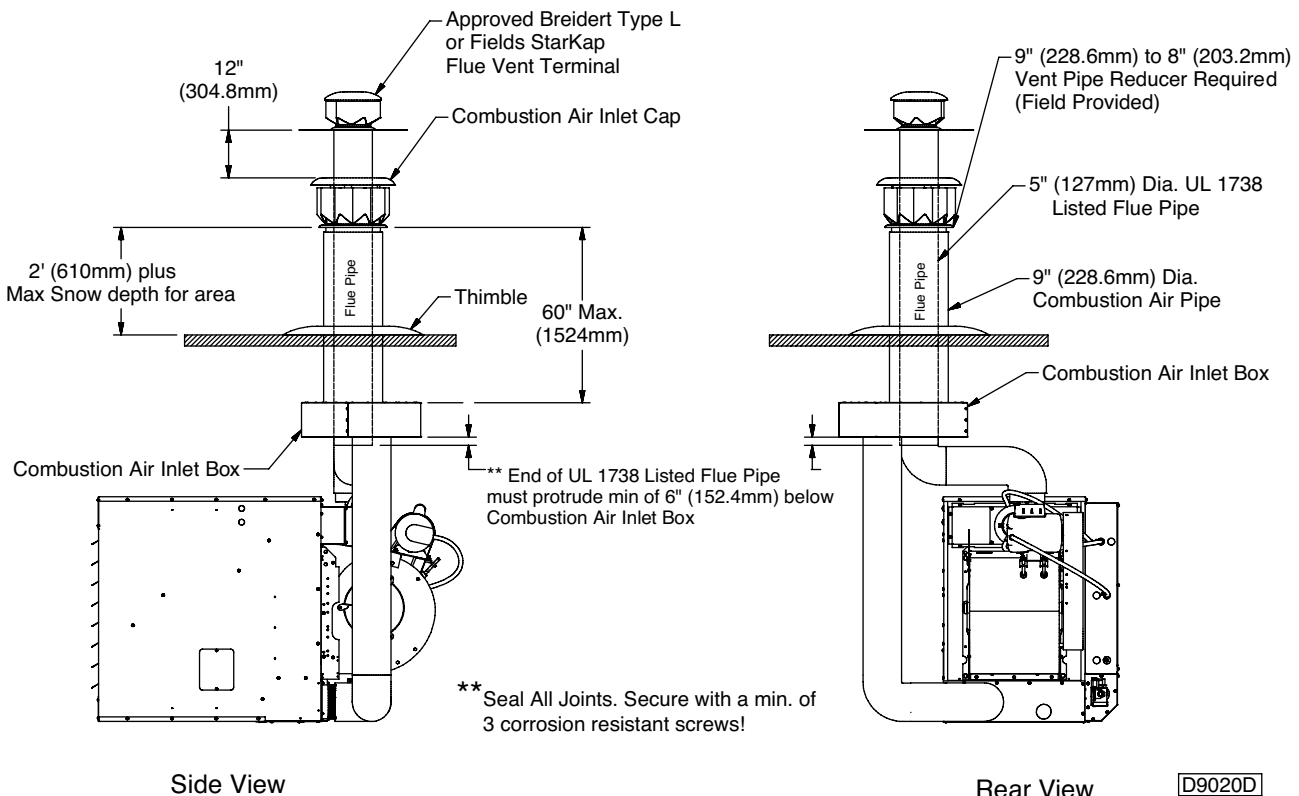

INSTALLATION (continued)

VERTICAL TERMINATION, 6 INCH KIT

FOR USE WITH 300-400 MBH UNITS ONLY

NOTICE: For unit sizes 300-400 MBH, there are two (2) 5 inch combustion air inlet collars on the burner panel to provide even air distribution across the burner. The collars should be connected via a field supplied tee. A 6 inch combustion air inlet pipe should then be used between the tee and the combustion air inlet box.

Select a location on the roof for vent terminal ensuring adequate space inside for combustion air inlet box. Vent terminal must be at least 10 feet (3.04m) from any wall or adjoining building. See Table 1 and Figure 3b.

Cut hole through the roof for 10 inch (254mm) combustion air pipe. The combustion air inlet box is to be suspended from the underside of the roof using suitable brackets (field supplied). Before mounting vent box, cut a length of 10 inch pipe so that dimension "A" Figure 4, Step 1 is equal to the roof thickness plus 18 inches (457mm) or the roof thickness plus the expected snow depth, whichever is greater. Fasten the 10 inch pipe to the combustion air inlet on the combustion air inlet box. Seal the joint and fasten with sheet metal screws.

Insert the pipe through the roof and fasten vent box into place (See Figure 4, Step 2). Flash and/or caulk 10 inch pipe to roof (See Figure 4, Step 3). Install the inlet air cap and fasten with sheet metal screws.

Insert a length of 6 inch UL 1738 listed vent pipe in the

direction of flow pointing upward through the air inlet vent cap. Vent pipe should be inserted into the combustion air inlet box so that the pipe extends a minimum of 6 inches (152mm) below the vent box for connection purposes. This will allow room to seal the flue pipe. Secure the UL 1738 listed pipe in position with 3 small, evenly spaced sheet metal screws. With high temperature silicone, seal the space between the UL 1738 listed pipe and the combustion air inlet box as well as the space between the UL 1738 listed pipe and the air inlet terminal (See Figure 4, Step 4).

Install the deflector disk on the UL 1738 listed vent pipe at least 12 inches (305mm) above the air inlet terminal and fasten with screws. Seal the joint between deflector disk and pipe with high temperature silicone.

Install the vent cap to the UL 1738 listed pipe using sheet metal screws. Ensure there is a minimum of 12 inches (305mm) between the bottom of the flue vent terminal and the top of the air inlet vent cap (See Figure 3b and Figure 4, Step 4). Connect flue pipe and combustion air pipe from the combustion air inlet box to the unit, following instructions in the manual provided with the unit and Combustion Air and Exhaust Venting instructions on pages 7 and 8.

▲ WARNING Never use pipe other than 6 inch diameter. Never use PVC, ABS or any other nonmetallic pipe for venting! To do so may result in serious damage to the unit and or severe personal injury or death!

Figure 3b – Vertical 6 Inch Combustion Air Inlet Kit Installation

Note: Separated Combustion Blower Type Unit Shown

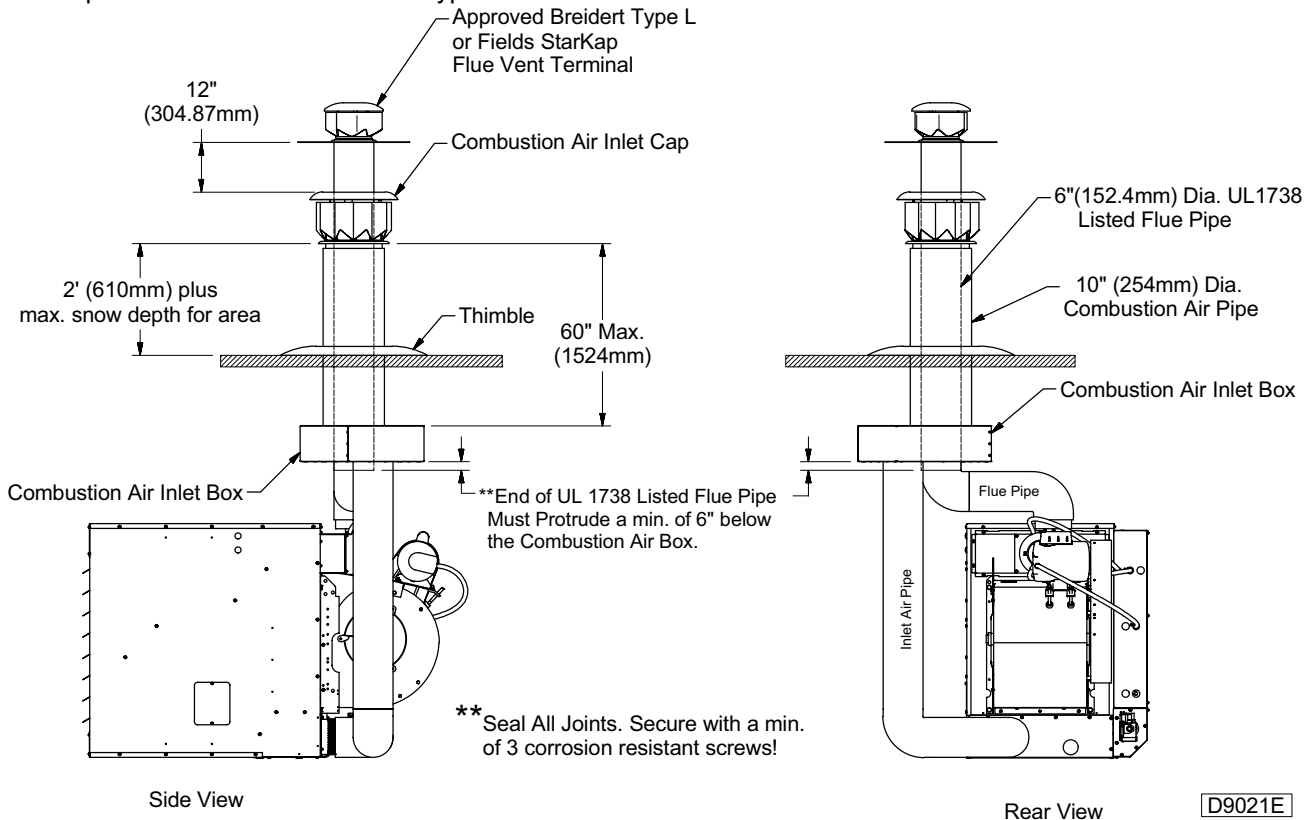

INSTALLATION (continued)

Figure 4 – Vertical Combustion Air Inlet Kit Installation

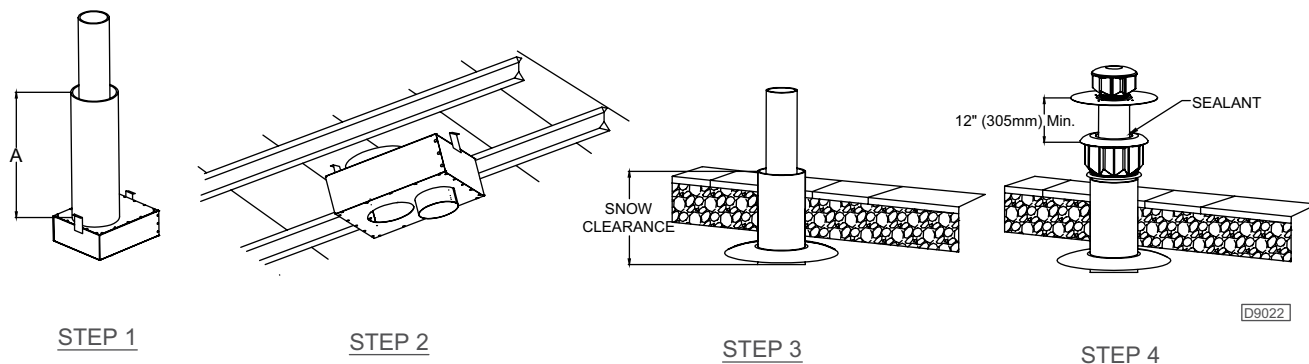

COMBUSTION AIR VENTING

▲ WARNING Never operate unit heaters without combustion air and flue gas piping in place or severe personal injury or death may occur!

▲ WARNING CARBON MONOXIDE!

Your venting system must not be blocked by any snow, snow drifts, or any foreign matter. Inspect your venting system to ensure adequate ventilation exists at all times! Failure to heed these warnings could result in Carbon Monoxide Poisoning (symptoms include grogginess, lethargy, inappropriate tiredness, or flu-like symptoms).

1. The combustion air system installation must be in accordance with the current edition of the National Fuel Gas Code-NFPA 54 or ANSI Z223.1 National Fuel Gas Code. In Canada, installation must be in accordance with CSA-B149.1 "Installation Code for Natural Gas Burning Appliances and Equipment" and CSA-B149.2 "Installation Code for Propane Burning Appliances and Equipment."
2. The combustion air inlet box, inlet air screen, deflector disk, and vent terminal provided with the unit heater must be installed at the termination point of the combustion air/vent system. See Figures 1a/1b, 2a/2b, 3a/3b and 4.
3. Each unit heater MUST have its own combustion air system. It MUST NOT be connected to other air

intake systems.

4. Combustion air intake duct may be PVC, CPVC, Type B vent, single wall, double wall or other material approved by local code authority. Never use duct size other than diameter stated in these instructions.
5. Long runs of single or double wall combustion air piping passing through an unheated space may require insulating if condensation becomes noticeable.
6. The combustion air system must be installed to prevent collection of condensate. Pitch horizontal pipes downward 1/4 inch per foot (21 mm/m) toward the inlet cap to facilitate drainage.
7. The equivalent length of the combustion air system must not be less than 5 feet (1.5m) and must not exceed 50 feet (15.2m), excluding flue pipe. Equivalent length equals the total length of straight pipe plus 10 feet (3.05m) for each 90° elbow and 4 feet (1.22m) for each 45° elbow.

NOTICE: For optimum performance keep the combustion air system as straight as possible.

8. Each joint must be secured with at least three corrosion resistant screws. Two full turns of 3M #425 Aluminum Foil Tape or its equivalent must then be used to seal each joint. General Electric RTV-108, Dow-Corning RTV-732 or an equivalent silicone sealant with a temperature rating of 500°F

INSTALLATION (continued)

may be used instead of the tape.

EXHAUST VENTING

▲ WARNING Never operate unit heaters without combustion air and flue gas piping in place or severe personal injury or death may occur!

1. Vent system installation must be in accordance with the current National Fuel Gas Code-NFPA 54 or ANSI Z223.1 National Fuel Gas Code. In Canada installation must be in accordance with CSA-B149.1 "Installation Code for Natural Gas Burning Appliances and Equipment" and CSA-B149.2. "Installation Code for Propane Burning Appliances and Equipment".
2. A factory supplied Combustion Air Inlet Kit (which includes a combustion air inlet box, air inlet screen, deflector disk, vent terminal and inlet air collar) MUST be installed at the termination point of the combustion air/vent system. See Figures 1a/1b, 2a/2b, 3a/3b, and 4.
3. Each unit heater MUST have its own vent system. It MUST NOT be connected to other vent systems or to a chimney.
4. Use UL 1738 listed single or double wall pipe for the vent system. For installations in Canada, use corrosion resistant and gas-tight, listed vent pipe conforming with local building codes, or in the absence of local building codes, with current CSA-B149.1, Installation Codes for Natural Gas Burning Appliances and Equipment or CSA-B149.2, Installation Codes for Propane Gas Burning Appliances and Equipment.

▲ WARNING Never use pipe other than 5 or 6 inch diameter with respective Combustion Air Inlet Kits. Never use PVC, ABS or any other nonmetallic pipe for venting! To do so may result in serious damage to the unit and or severe personal injury or death!

5. Any run of single or double wall vent pipe passing through an unheated space must be insulated with insulation suitable to 550°F.
6. The vent system must be installed to prevent collection of condensate. Pitch horizontal pipes downward 1/4 inch per foot (21mm per meter) toward the vent cap to facilitate drainage.
7. The equivalent length of the vent system must not be less than 5 feet (1.5m) and must not exceed 50 feet (15.2m), excluding combustion air pipe. The equivalent length equals the total length of straight pipe plus 10 feet (3.05m) for each 90° elbow and 4 feet (1.22m) for each 45° elbow.
8. The exhaust vent system must remain at a minimum distance of 1 inch (25mm) from all combustible materials. Any part of the vent system that passes through a combustible material must be properly insulated.

NOTICE: Increasing the clearance distances may be necessary if there is a possibility of distortion or discoloration of adjacent materials.