

INSTALLATION INSTRUCTIONS AND SERVICE MANUAL TUBULAR INDOOR GAS-FIRED DUCT FURNACE

ATTENTION: READ THIS MANUAL AND ALL LABELS ATTACHED TO THE UNIT CAREFULLY BEFORE ATTEMPTING TO INSTALL, OPERATE, OR SERVICE THESE UNITS! CHECK UNIT DATA PLATE FOR TYPE OF GAS AND ELECTRICAL SPECIFICATIONS AND MAKE CERTAIN THAT THESE AGREE WITH THOSE AT THE POINT OF INSTALLATION. RECORD THE UNIT MODEL AND SERIAL No.(s) IN THE SPACE PROVIDED. RETAIN FOR FUTURE REFERENCE.

Unit No. _____ Serial No. _____

FOR YOUR SAFETY

The use and storage of gasoline or other flammable vapors and liquids in open containers in the vicinity of this appliance is hazardous.

FOR YOUR SAFETY

If you smell gas:

1. Open windows.
2. Do not touch electrical switches.
3. Extinguish any open flame.
4. Immediately contact your gas supplier.



▲ WARNING Improper installation, adjustment, alteration, service, or maintenance can cause property damage, injury, or death. Read the installation, operating and maintenance instructions thoroughly before installing or servicing this equipment.

APPROVED FOR USE IN CALIFORNIA

▲ WARNING Install, operate, and maintain unit in accordance with the manufacturer's instructions to avoid exposure to fuel substances, or substances from incomplete combustion, which can cause death or serious illness. The state of California has determined that these substances may cause cancer, birth defects, or other reproductive harm.

INSTALLER'S RESPONSIBILITY

Installer Please Note: This equipment has been test fired and inspected. It has been shipped free from defects from our factory. However, shipment and installation problems such as loose wires, leaks, or loose fasteners may occur. **It is the installer's responsibility to inspect and correct any problems that may be found.**

RECEIVING INSTRUCTIONS

Inspect shipment immediately when received to determine if any damage has occurred to the unit during shipment. After the unit has been uncrated, check for any visible damage to the unit. If any damage is found, the consignee should sign the bill of lading indicating such damage and immediately file claim for damage with the transportation company.



MESTEK, INC.

260 NORTH ELM ST., WESTFIELD, MA 01085

TEL: (413) 564-5540 FAX: (413) 562-5311

www.mestek.com



TABLE OF CONTENTS

GENERAL SAFETY INFORMATION	
Installation Codes	2, 3
Special Precautions	2, 3
Converting SI/Metric Unit Measurements	3
SPECIFICATIONS	
Basic Description	2
Dimensional Data	4
Performance Data	5
INSTALLATION	
Locating Units	6
Safety Clearances	6
Accessibility Clearances	6
Ductwork	7
Airflow, Combustion Inlet Air Ventilation	7
Suspension	8
Conversion of Access Side	9
Gas Pipe Sizing	9
Pipe Installation	10, 11
ELECTRICAL CONNECTIONS	12-14
VENTING	
General Venting Information.....	15, 16
Standard Combustion.....	17-19
Separated Combustion.....	20-22
OPERATION	
Explanation of Controls.....	25
Start-Up and Shutdown.....	25
Gas Input Rate.....	26
High Altitude Deration.....	26, 27
MAINTENANCE	28
IDENTIFICATION OF PARTS	29
TROUBLESHOOTING GUIDES	30-34
WARRANTY	35
UNIT NUMBER DESCRIPTION	35
EQUIPMENT START-UP SHEET	36

DESCRIPTION

The Tubular Indoor Gas-Fired Duct Furnace is a factory assembled, power vented, and low static pressure type duct furnace with a low profile cabinet. The duct furnace can also be easily field converted to separated combustion. The design is certified by ETL as providing

a minimum of 82% thermal efficiency, and approved for use in California. Do not alter these units in any way. If you have any questions after reading this manual, contact the manufacturer.



GENERAL SAFETY INFORMATION

The tubular duct furnace design is certified by ETL for use with natural and propane (LP) gases. ANSI and NFPA Standards as well as Canadian installation codes referred to in this manual are the ones that were applicable at the time the design was certified.

The following terms are used throughout this manual, in addition to ETL requirements, to bring attention to the presence of potential hazards or to important information concerning the product:

▲ DANGER Indicates an imminently hazardous situation which, if not avoided, will result in death, serious injury, or substantial property damage.

▲ WARNING Indicates an imminently hazardous situation which, if not avoided, could result in death, serious injury, or substantial property damage.

▲ CAUTION Indicates an imminently hazardous situation which, if not avoided, may result in minor injury or property damage.

NOTICE: Used to notify of special instructions on installation, operation, or maintenance which are important to equipment but not related to personal injury hazards.

GENERAL SAFETY INFORMATION

▲ WARNING Failure to comply with the general safety information may result in extensive property damage, sever personal injury, or death.

▲ WARNING This product must be installed by a licensed plumber or gas fitter when installed within the Commonwealth of Massachusetts.

Installation must be made in accordance with local codes, or in absence of local codes, with the latest edition of the National Fuel Gas Code, ANSI Standard Z223.1 (NFPA 54). All of the ANSI and NFPA Standards referred to in these installation instructions are those that were applicable at the time the design of this appliance was certified. The ANSI Standards are available from the CSA Information Services, 1-800-463-6727, as well as at www.ansi.org. The NFPA Standards are available from the National Fire Protection Association, 1 Batterymarch Park, Quincy, MA 02169, as well as at www.nfpa.org. These duct furnaces are designed for use in airplane hangars when installed in accordance with current ANSI/NFPA No. 409 and in public garages when installed in accordance with current NFPA No. 88A and NFPA No. 88B.

If installed in Canada, the installation must conform with local building codes, or in absence of local building codes, with CSA-B149.1 "Installation Codes for Natural Gas Burning Appliances and Equipment" or CSA-B149.2 "Installation Codes for Propane Gas Burning Appliances and Equipment." These indoor duct furnaces have been designed and certified to comply with CSA 2.6. Also see sections on installation in AIRCRAFT HANGARS and PUBLIC GARAGES.

▲ WARNING Do not alter the duct furnace in any way or damage to the unit and/or severe personal injury, or death may occur!

▲ WARNING Disconnect all power and gas supplies before installing or servicing the heater. If the power disconnect is out of sight, lock it in the open position and tag it to prevent unexpected application of power. Failure to do so could result in fatal electric shock, or severe personal injury.

▲ CAUTION Ensure that all power sources conform to the requirements of the unit heater or damage to the unit will result!

Follow installation instructions CAREFULLY to avoid creating unsafe conditions. All wiring should be done and checked by a qualified electrician, using copper wire only. All external wiring must conform to applicable local codes, and to the latest edition of the National Electric Code ANSI/NFPA No. 70. All gas connections should be made and leak-tested by a suitable qualified individual, per instructions in this manual.

Also, follow procedures listed on the "Gas Equipment Start-up" sheet located on the back cover of this manual.

Use only the fuel for which the heater is designed (see rating plate). Using LP gas in a heater that requires natural gas, or vice versa, will create the risk of gas leaks, carbon monoxide poisoning and explosion.

▲ WARNING Do not attempt to convert the heater for use with a fuel other than the one intended unless using an appropriate conversion kit provided by the manufacturer. Such conversion is dangerous and could create unsafe conditions that result in death, serious personal injury or property damage.

Make certain that the power source conforms to the electrical requirements of the heater.

▲ WARNING Do not depend upon a thermostat or other switch as sole means of disconnecting power when installing or servicing heater. Always disconnect power at the main circuit breaker as described above. Failure to do so could result in fatal electric shock.

Special attention must be given to any grounding information pertaining to this heater. To prevent the risk of electrocution, the heater must be securely and adequately grounded. This should be accomplished by connecting a grounded conductor between the service panel and the heater. To ensure a proper ground, the grounding means must be tested by a qualified technician.

Do not insert fingers or foreign objects into the heater or its combustion air moving device. Do not block or tamper with the heater in any manner while in operation or just after it has turned off, as some parts may be hot enough to cause injury.

This heater is intended for general heating applications ONLY. It must NOT be used in potentially dangerous locations such as flammable, explosive, chemical-laden or wet atmospheres.

In cases in which property damage may result from malfunction of the heater, a backup system or a temperature sensitive alarm should be used.

▲ CAUTION The open end of gas piping systems being purged shall not be discharged into areas where there are sources of ignition or into confined spaces UNLESS precautions are taken as follows: (1) By ventilation of the space, (2) control of purging rate, (3) elimination of all hazardous conditions. All precautions must be taken to perform this operation in a safe manner!

Unless otherwise specified, the following conversions may be used for calculating SI unit measurements:

1 foot = 0.305 m	1000 BTU per hour = 0.293 kW
1 inch = 25.4 mm	1 inch water column = 0.249 kPa
1 gallon = 3.785 L	1000 BTU/Cu.Ft. = 37.5 MJ/m ³
1 pound = 0.453 kg	Liter/second = CFM x 0.472
1 psig = 6.894 kPa	Meter/second = FPM ÷ 196.8
1 cubic foot = 0.028 m ³	

DIMENSIONAL DATA

Table 1 - Tubular Duct Furnace Dimensions

Unit Capacity	100	150	200	250	300	350	400
Dimensional Data - inches (mm)							
"A" Overall Unit Height	10.3 (262)	13.7 (348)	17 (432)	20.2 (513)	23.5 (597)	26.7 (678)	30 (762)
"B" Height to Centerline Flue	7.6 (193)	10.5 (267)	11.9 (302)	6.8 (173)	8.4 (213)	10 (254)	11.6 (295)
"C" Height to Gas Connection	2.5 (64)	3.7 (94)	5.3 (135)	7 (178)	7 (178)	8.7 (221)	10.3 (262)
"D" Opening Height, Front & Rear	8.5 (216)	11.7 (297)	15 (381)	18.2 (462)	21.5 (546)	24.7 (627)	28 (711)
"E" Overall Unit Depth	32.7 (831)	32.7 (831)	32.7 (831)	33.5 (851)	33.5 (851)	33.5 (851)	33.5 (851)
"F" Flue Size Diameter	5 (127)	5 (127)	5 (127)	6 (152)	6 (152)	6 (152)	6 (152)
"G" Air Inlet Size Diameter	5 (127)	5 (127)	5 (127)	6 (152)	6 (152)	6 (152)	6 (152)
Gas Inlet, Natural Gas - inch	1/2	1/2	1/2	3/4	3/4	3/4	3/4
Gas Inlet, LP Gas - inch	1/2	1/2	1/2	3/4	3/4	3/4	3/4
Approximate Unit Weight - lb	160	221	250	270	296	321	355
(kg)	(73)	(100)	(113)	(122)	(134)	(146)	(161)
Approximate Ship Weight - lb	270	331	360	403	429	454	488
(kg)	(122)	(150)	(163)	(183)	(195)	(206)	(221)

Figure 1 - Tubular Duct Furnace Dimensions

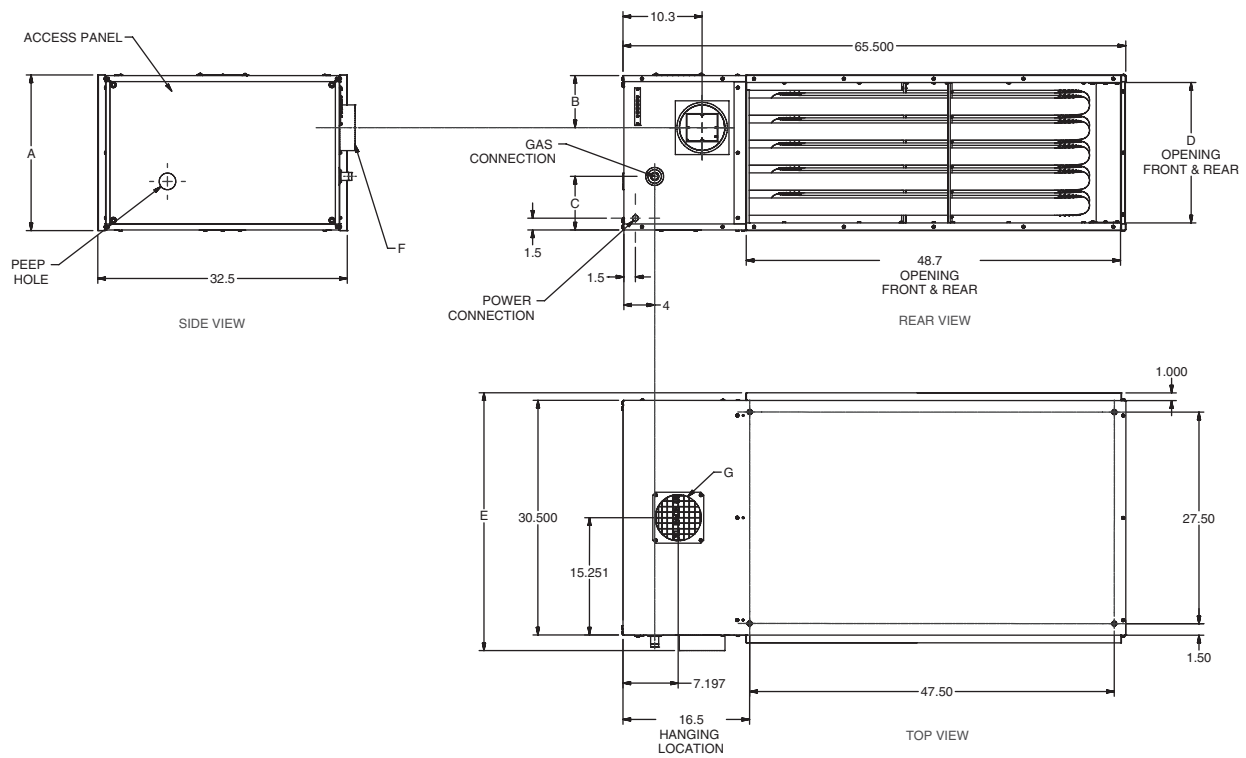

D9362

PERFORMANCE DATA

Table 2 - Tubular Duct Furnace Performance Data

UNIT SIZE	INPUT		OUTPUT MBH (kW)	Full Load Amps	MCA	Minimum CFM (cu. m/s)	Temp. Rise °F (°C)	P.D. in. W.C. (kPa)	Maximum CFM (cu. m/s)	Temp. Rise °F (°C)	P.D. in. W.C. (kPa)
	(Max.) MBH (kW)	(Min.) MBH (kW)									
100	100 (29.3)	50 (14.6)	82 (24.0)	2.2	2.5	758 (0.357)	100 (56)	0.07 (0.017)	2528 (1.193)	30 (17)	0.65 (0.16)
150	150 (43.9)	75 (21.9)	123 (36.0)	2.2	2.5	1137 (0.536)	100 (56)	0.03 (0.007)	3792 (1.789)	30 (17)	0.44 (0.11)
200	200 (58.6)	100 (29.3)	164 (48.0)	2.2	2.5	1517 (0.715)	100 (56)	0.04 (0.009)	5057 (2.386)	30 (17)	0.54 (0.13)
250	250 (73.2)	125 (36.6)	205 (60.0)	1.8	1.9	1896 (0.894)	100 (56)	0.08 (0.019)	6321 (2.983)	30 (17)	0.76 (0.19)
300	300 (87.8)	150 (43.9)	246 (72.0)	1.8	1.9	2275 (1.074)	100 (56)	0.03 (0.007)	7585 (3.579)	30 (17)	0.69 (0.16)
350	350 (102.5)	175 (51.2)	287 (84.1)	1.8	1.9	2654 (1.252)	100 (56)	0.07 (0.017)	8849 (4.176)	30 (17)	0.76 (0.19)
400	400 (117.1)	200 (58.6)	328 (96.1)	1.8	1.9	3034 (1.431)	100 (56)	0.08 (0.019)	10,114 (4.773)	30 (17)	0.70 (0.17)

Ratings are shown for unit installations at elevations between 0 and 2,000 feet (610m). For unit installations in U.S.A. above 2,000 feet (610m), the unit input must be field derated 4% for each 1,000 feet (305m) above sea level; refer to local codes, or in absence of local codes, refer to the latest edition of the National Fuel Gas Code, ANSI Standard Z223.1 (NFPA 54). For installations in Canada, any references to deration at altitudes in excess of 2,000 feet (610m) are to be ignored. At altitudes of 2,000 to 4,500 feet (610 to 1372m), the unit must be field derated and be so marked in accordance with the ETL certification. See Table 7A for U.S.A. and Canadian field deration information.

Figure 2

Temperature Rise and Pressure Drop Graph

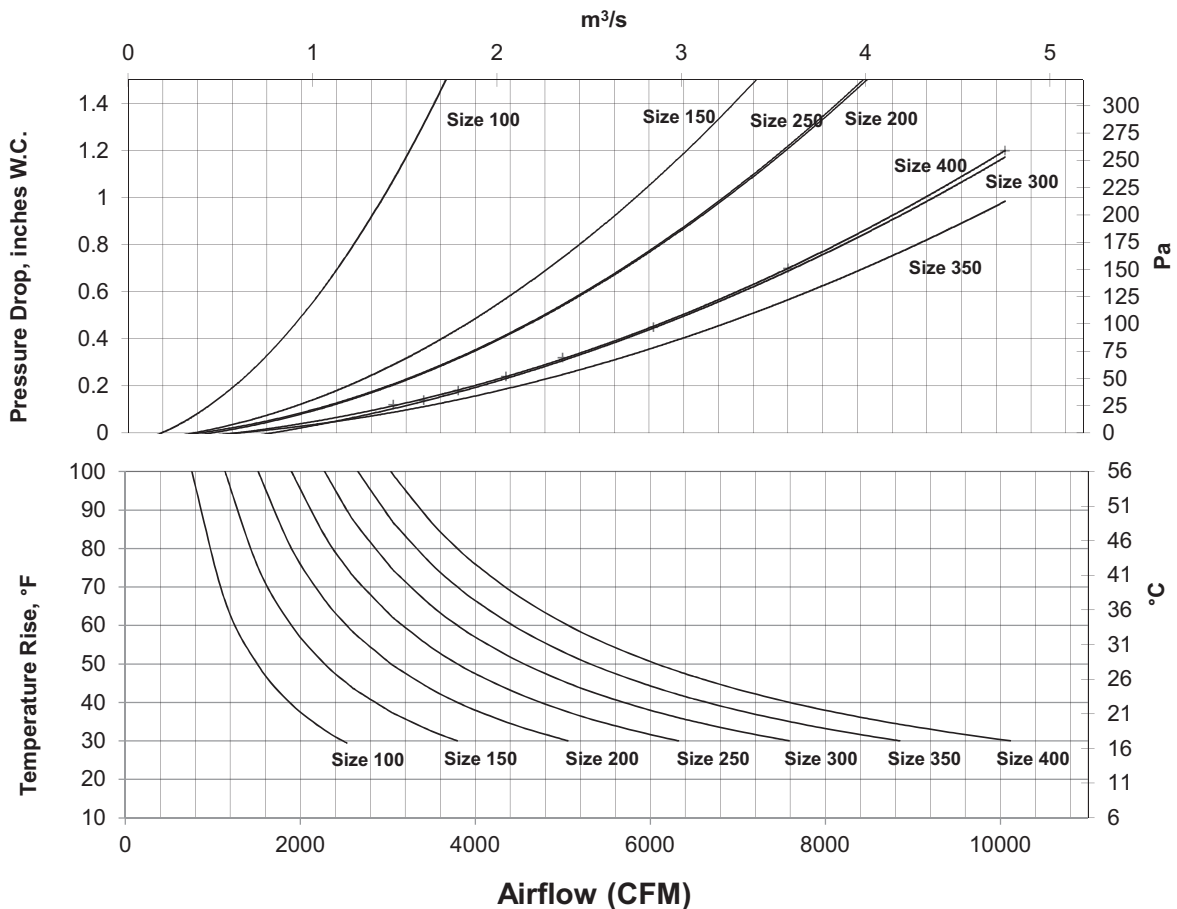

INSTALLATION

LOCATING UNITS

▲ CAUTION Do not install duct furnaces in corrosive or flammable atmospheres! Premature failure of, or severe damage to the unit will result!

▲ CAUTION Avoid locations where extreme drafts can affect burner operation. Duct furnaces must not be installed in locations where air for combustion would contain chlorinated, halogenated, or acidic vapors. If located in such an environment, premature failure of the unit will occur!

NOTICE: Location of duct furnaces is related directly to the selection of sizes. Basic rules are as follows:

CLEARANCES

▲ WARNING Under no circumstances should combustible material be located within the clearances specified in Table 3. Failure to provide proper clearance could result in personal injury or equipment damage from fire.

Maintain adequate clearances around air openings into the combustion chamber:

Table 3 - Minimum Safety Clearances*

Sides	6 inches (152mm)
Top	6 inches (152mm)
Bottom	6 inches (152mm)
Flue	6 inches (152mm)

* When clearances required for accessibility are greater than the minimum safety clearances, the accessibility clearances take precedence.

ACCESSIBILITY CLEARANCE: The duct furnace must have 18 inches (457mm) clearance on the control cabinet end. Provision should also be made to assure accessibility for recurrent maintenance purposes.

ATMOSPHERIC CONSIDERATIONS: Atmospheres containing commercial solvents or chlorinated hydrocarbons will produce corrosive acids when coming in contact with the flames. This will greatly reduce the life of the gas duct furnace and may void the warranty. Avoid such areas.

NOTICE: If the gas duct furnace is to be used in a building classified as having a hazardous atmosphere, the installation must comply with the standards set by the National Board of Fire Underwriters. Consult the authorities having jurisdiction before starting the job.

The duct furnace must be installed on the positive pressure side of the air circulation blower.

AIRCRAFT HANGARS: In aircraft hangars, duct furnaces must be at least 10 feet (3.05m) above the upper surface of wings or engine enclosures of the highest aircraft to be stored in the hangar and 8 feet (2.4m) above the floor in shops, offices, and other sections of the hangar where aircraft are not stored and housed. Refer to current ANSI/NFPA No. 409, Aircraft Hangars. In Canada, installation is suitable in aircraft hangars when acceptable to the enforcing authorities.

PUBLIC GARAGES: In repair garages, duct furnaces must be installed in a detached building or room separated from repair areas as specified in the latest edition of NFPA 88B, Repair Garages.

In parking structures, duct furnaces must be installed so that the burner flames are located a minimum of 18 inches (457mm) above the floor or protected by a partition not less than 18 inches (457mm) high. Refer to the latest edition of NFPA 88A, Parking Structures.

In Canada, installation must be in accordance with the latest edition of CSA B149 "Installation Codes for Gas Burning Appliances and Equipment."

NOTICE: The duct furnace must be installed such that the gas ignition control system is not directly exposed to water spray, rain, or dripping water.

Duct furnaces should not be installed to maintain low temperatures and/or freeze protection of buildings. A minimum of 50°F (10°C) thermostat setting must be maintained. If duct furnaces are operated to maintain lower than 50°F (10°C), hot flue gases are cooled inside the heat exchanger to the point where water vapor (a flue gas byproduct) condenses onto the heat exchanger walls. The result is a mildly corrosive acid that prematurely corrodes the aluminized steel heat exchanger and can actually drip water down from the duct furnace onto the floor surface below. Additional duct furnaces should be installed if a minimum 50°F (10°C) thermostat setting cannot be maintained.

INSTALLATION (continued)

DUCTWORK

Properly designed and installed ductwork, providing a uniformly distributed flow of air across all surfaces of the heat exchanger, is essential to satisfactory unit performance and life of the equipment.

All duct connection flanges/seams must be sealed to prevent air leaks. Sealant/tape must be suitable for temperatures of 250°F (121°C) minimum.

▲ WARNING Any attempts to straighten the 90° duct connection flanges on the duct furnaces will affect the operation of the furnace and will void the warranty.

If uniform air distribution is not obtained, install additional baffles and/or turning vanes in the ductwork.

Figures 3 and 4 illustrate recommended ductwork designs for both the straight-through and elbowed air inlet arrangements.

Access panels large enough to observe smoke and reflected light, and to detect the presence of leaks in the heating equipment, are required both upstream and downstream from gas duct furnaces. These panels must be sealed to prevent air leaks. If allowed by local regulations, install canvas connectors between the ductwork and fan discharge opening to eliminate the transmission of mechanical vibration.

AIR FLOW

The installation is to be adjusted to obtain an air throughput within the range specified on the appliance rating plate.

COMBUSTION INLET AIR VENTILATION

Inlet Air From Another Room – If the duct furnace is installed in a separate room or compartment, provide two inlet air openings. The size of each vent opening should be no less than one square inch (6.452 square centimeters) of free area for each 1000 Btu/hr. (293 W) input. Each opening must not be less than 100 square inches (645 square centimeters).

Inlet Air From Outdoors – If the enclosed space is to have inlet combustion air from the outside, the vent opening should be no less than one square inch (6.452 square centimeters) of free area for each 2500-3000 Btu/hr. (733-879 W) input. Each opening must not be less than 100 square inches (645 square centimeters).

CONDENSATE

The duct furnace may be installed on the downstream side of a cooling coil, without need of a bypass duct. In some space conditions, condensate can form in the heat exchanger of the duct furnace when installed downstream from a cooling coil. Under these conditions, a field provided drain flange (also referred to as a waste nut) may be installed on the furnace bottom.

To install the drain flange, a hole should be drilled in the bottom of the burner section. The drain flange should then be bolted to the exterior of the unit, directly over the hole in the bottom of the drain pan. Any holes in the bottom of the pan not covered by the drain flange, should be sealed with RTV sealant. Condensate piping should terminate outside of the building. Periodic cleaning of the condensate piping is required to ensure proper condensate flow.

BYPASS

When a gas duct furnace is installed to operate in conjunction with a summer air conditioning system, the CFM air delivery of the system blower should be adjusted to meet the design air volume requirements for cooling. If this CFM delivery is greater than that required for heating, resulting in a low air temperature rise, install a damper bypass around the gas duct furnace to bypass a portion of the air.

Figure 3 - Recommended Ductwork Design for Straight-Through Arrangement

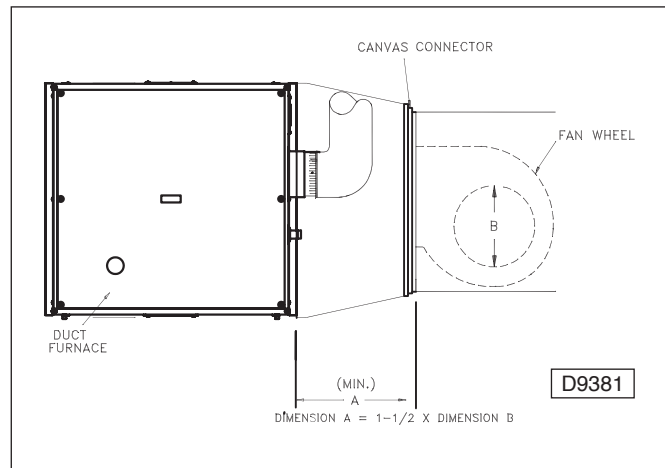
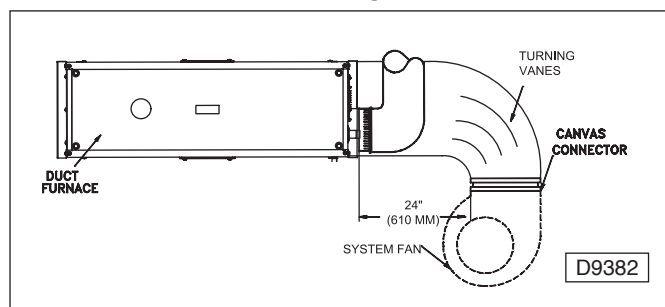

Figure 4 - Recommended Ductwork Design for Elbowed Arrangement



INSTALLATION (continued)

SUSPENSION

Figure 5 - Typical Suspension

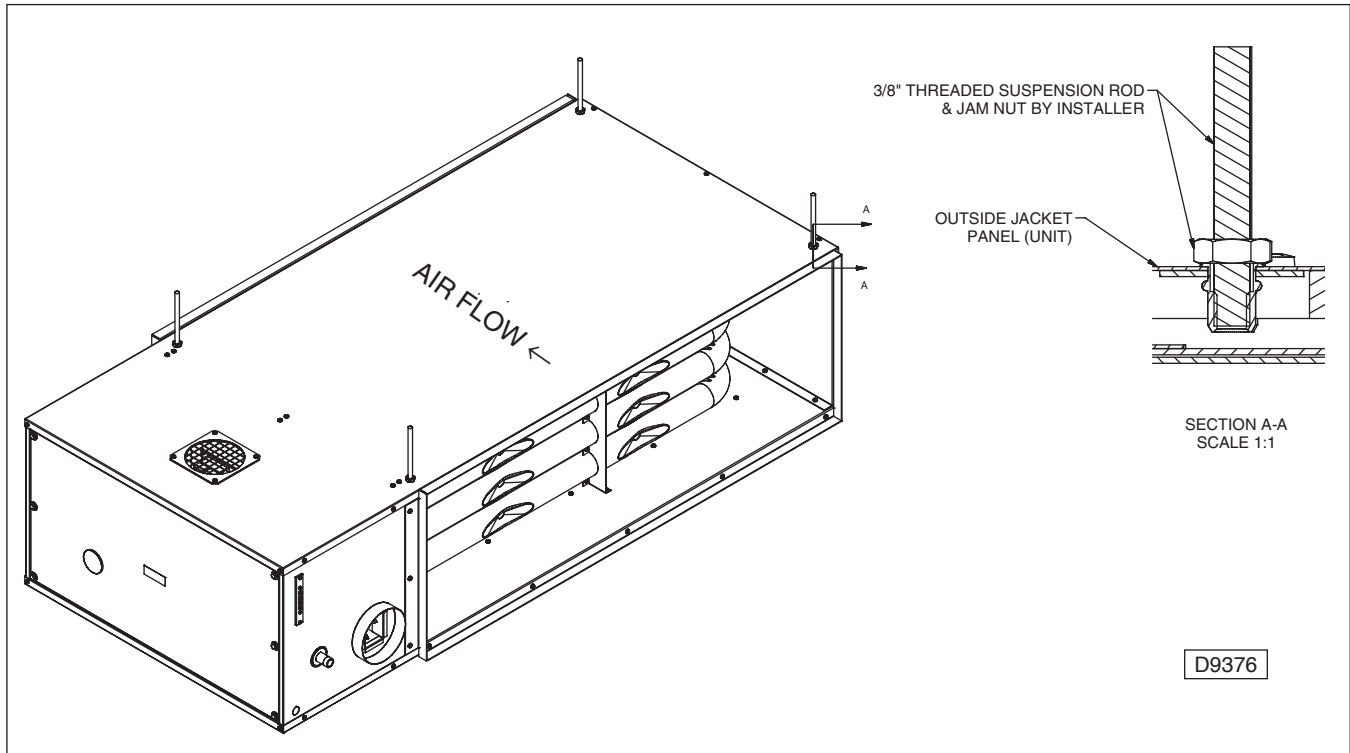

▲ WARNING Ensure that all hardware used in the suspension of each duct furnace is more than adequate for the job. Failure to do so may result in extensive property damage, personal injury or death. Washers should not be used between the unit nutsert and jam nut. Use of a washer may cause the nutsert to become dislodged from the unit.

▲ CAUTION The duct furnace must be hung level from side to side and front to back, from four suspension points provided at the top of the unit. Failure to do so will result in poor performance and/or premature failure of the unit. Refer to Figure 5 for typical suspension. **DO NOT** mount duct furnaces in series (one in front of another).

NOTICE: Minimum safety clearances must also be maintained; see Table 3. When service/accessibility clearances are greater than minimum safety clearances, service/accessibility clearances take precedence. See "Clearances" section under "Installation."

▲ WARNING Make certain that the lifting methods used to lift the duct furnace are capable of supporting the weight of the heater during installation. Failure to heed this warning may result in property damage or personal injury. See Table 1 for unit weights.

▲ WARNING Make certain that the structure to which the duct furnace is to be mounted is capable of safely supporting its weight. Under no circumstances must the gas lines, venting system, or the electrical conduit be used to support the duct furnace or any other objects (i.e. ladder, person) lean against the gas lines, venting system, or electrical conduit for support. Failure to heed these warnings may result in property damage, personal injury, or death.

INSTALLATION (continued)

CONVERSION OF ACCESS SIDE

The tubular duct furnace is built and shipped as left side access – when looking in the direction of airflow, gas and flue connections, control cabinet access are on the left hand side and the combustion air inlet is on top. When looking in the direction of airflow, you will be facing the entering air side of the duct furnace. To convert the unit to right side access:

1. Before suspending unit, flip the duct furnace 180 degrees widthwise (not rotated) so the gas and flue connections are still on the entering air side of the duct furnace.
2. Remove the four (4) screws holding the combustion air inlet screen (now located on the bottom of the unit); the screen and gasket can be removed and set aside.
3. Remove the four (4) screws holding the block-off plate (now located on the top of the unit); the plate and the gasket can be removed and set aside.
4. Reinstall the block-off plate and its gasket on the bottom of the unit using the four (4) screws.
5. Reinstall the combustion air inlet screen and its gasket on the top of the unit using the four (4) screws.
6. For units with modulating gas control: after the unit has been flipped, the modulating gas valve must be rotated so that it is in the upright position.

NOTICE: Steps 2-5 above can be used to convert the unit to bottom combustion air inlet without converting the access side.

It is not required to switch the combustion air inlet screen and block-off plate locations once the unit has been flipped. However, due to combustion noise, it is recommended to keep the air inlet screen on top for overhead installations.

NOTICE: If unit access side is converted, ensure accessibility clearance is taken into account for the new control cabinet end of the unit before suspension/installation.

GAS PIPE SIZING

▲ WARNING To avoid damage or possible personal injury, do not connect gas piping to this unit until a supply line pressure/leak test has been completed. Connecting the unit before completing the pressure/leak test may damage the unit gas valve and result in a fire hazard.

▲ WARNING Do not rely on a shut-off valve to isolate the unit while conducting gas pressure/leak tests. These valves may not be completely shut off, exposing the gas valve to excessive pressure and damage.

PIPE SIZING

To provide adequate gas pressure to the gas unit heater, size the gas piping as follows:

1. Find the cu. feet/hr. by using the following formula:
$$\text{Cu. ft./hr.} = \frac{\text{Input BTU/Hr.}}{1000}$$
2. Refer to Table 4. Match “Length of Pipe in Feet” with appropriate “Gas Input - Cu. Ft./Hr.” figure. This figure can then be matched to the pipe size at the top of the column.

Example:

It is determined that a 67 foot (20.4m) run of gas pipe is required to connect a 200 MBTU gas unit heater to a 1,000 BTU/cu feet (0.29kW) natural gas supply.

$$\frac{200,000 \text{ BTU/Hr.}}{1,000 \text{ BTU/cu. feet}} = 200 \text{ Cu. ft./hr.}$$

Using Table 4, a 1 inch pipe is needed.

NOTE: See General Safety Information section for English/Metric unit conversion factors.

NOTICE: If more than one unit heater is to be served by the same piping arrangement, the total cu. ft./hr. input and length of pipe must be considered.

NOTICE: If the gas unit heater is to be fired with LP gas, consult your local LP gas dealer for pipe size information.

NOTICE: HEATER INSTALLATION FOR USE WITH PROPANE (BOTTLED) GAS MUST BE MADE BY A QUALIFIED L.P. GAS DEALER OR INSTALLER. HE/SHE WILL INSURE THAT PROPER JOINT COMPOUNDS ARE USED FOR MAKING PIPE CONNECTIONS; THAT AIR IS PURGED FROM LINES; THAT A THOROUGH TEST IS MADE FOR LEAKS BEFORE OPERATING THE HEATER; AND THAT IT IS PROPERLY CONNECTED TO THE PROPANE GAS SUPPLY SYSTEM.

Before any connection is made to the existing line supplying other gas appliances, contact the local gas company to make sure that the existing line is of adequate size to handle the combined load.

INSTALLATION (continued)

Table 4 - Gas Pipe Size

Maximum Capacity of Pipe in Cubic Feet of Gas per Hour (Cubic Meters per Hour) for Gas Pressures of 0.5 psig (3.5 kPa) or Less, and a Pressure Drop of 0.5 Inch Water Column (124.4 Pa)
(Based on a 0.60 Specific Gravity Gas)

Nominal Iron Pipe Size	Internal Diameter	Length of Pipe, Feet (meters)													
		10 (3.0)	20 (6.1)	30 (9.1)	40 (12.2)	50 (15.2)	60 (18.3)	70 (21.3)	80 (24.4)	90 (27.4)	100 (30.5)	125 (38.1)	150 (45.7)	175 (53.3)	200 (61.0)
1/2	0.622	175 (4.96)	120 (3.40)	97 (2.75)	82 (2.32)	73 (2.07)	66 (1.87)	61 (1.73)	57 (1.61)	53 (1.50)	50 (1.42)	44 (1.25)	40 (1.13)	37 (1.05)	35 (0.99)
3/4	0.824	360 (10.2)	250 (7.08)	200 (5.66)	170 (4.81)	151 (4.28)	138 (3.91)	125 (3.54)	118 (3.34)	110 (3.11)	103 (2.92)	93 (2.63)	84 (2.38)	77 (2.18)	72 (2.04)
1	1.049	680 (19.3)	465 (13.2)	375 (10.6)	320 (9.06)	285 (8.07)	260 (7.36)	240 (6.80)	220 (6.23)	205 (5.80)	195 (5.52)	175 (4.96)	160 (4.53)	145 (4.11)	135 (3.82)
1 1/4	1.380	1400 (39.6)	950 (26.9)	770 (21.8)	660 (18.7)	580 (16.4)	530 (15.0)	490 (13.9)	460 (13.0)	430 (12.2)	400 (11.3)	360 (10.2)	325 (9.20)	300 (8.50)	280 (7.93)
1 1/2	1.610	2100 (59.5)	1460 (41.3)	1180 (33.4)	990 (28.0)	900 (25.5)	810 (22.9)	750 (21.2)	690 (19.5)	650 (18.4)	620 (17.6)	550 (15.6)	500 (14.2)	460 (13.0)	430 (12.2)
2	2.067	3950 (112)	2750 (77.9)	2200 (62.3)	1900 (53.8)	1680 (47.6)	1520 (43.0)	1400 (39.6)	1300 (36.8)	1220 (34.5)	1150 (32.6)	1020 (28.9)	950 (26.9)	850 (24.1)	800 (22.7)
2 1/2	2.469	6300 (178)	4350 (123)	3520 (99.7)	3000 (85.0)	2650 (75.0)	2400 (68.0)	2250 (63.7)	2050 (58.0)	1950 (55.2)	1850 (52.4)	1650 (46.7)	1500 (42.5)	1370 (38.8)	1280 (36.2)
3	3.068	11000 (311)	7700 (218)	6250 (177)	5300 (150)	4750 (135)	4300 (122)	3900 (110)	3700 (105)	3450 (97.7)	3250 (92.0)	2950 (83.5)	2650 (75.0)	2450 (69.4)	2280 (64.6)
4	4.026	23000 (651)	15800 (447)	12800 (362)	10900 (309)	9700 (275)	8800 (249)	8100 (229)	7500 (212)	7200 (204)	6700 (190)	6000 (170)	5500 (156)	5000 (142)	4600 (130)

1. Determine the required Cu. Ft./Hr. by dividing the input by 1000. For SI/Metric measurements: Convert BTU/Hr. to kilowatts. Multiply the units inputs (kW) by 0.0965 to determine Cu. Meters./Hr. 2. FOR NATURAL GAS: Select pipe size directly from the table. 3. FOR PROPANE GAS: Multiply the Cu. Ft./Hr. value by 0.633; then, use the table. 4. Refer to the metric conversion factors listed in the General Safety section for SI Unit measurement conversions.

PIPE INSTALLATION

1. Install the gas piping in accordance with applicable local codes.
2. Check gas supply pressure. Each duct furnace must be connected to a manifold pressure and a gas supply capable of supplying its full rated capacity as specified in Table 5. A field LP tank regulator must be used to limit the supply pressure to a maximum of 14 inches W.C. (3.5 kPa). All piping should be sized in accordance with the latest edition of ANSI Standard Z223.1 (NFPA 54), National Fuel Gas Code; in Canada, according to CSA B149. See Tables 1 & 4 for correct gas piping size. If gas pressure is excessive on natural gas applications, install a pressure regulating valve in the line upstream from the main shutoff valve.
3. Adequately support the piping to prevent strain on the gas manifold and controls.
4. To prevent the mixing of moisture with gas, run the take-off piping from the top, or side, of the main.
5. Standard duct furnaces, optional two-stage and modulation units are supplied with a combination valve which includes:
 - a. Manual "A" valve
 - b. Manual "B" valve
 - c. Solenoid valve
 - d. Pressure regulator
 Pipe directly into the combination valve (see Figure 6).

6. Gas valve has a pressure test post requiring a 3/32 inch hex head wrench to read gas supply and manifold pressures. Open 1/4 turn counterclockwise to read, turn clockwise to close and reseal. A 5/16 inch ID hose fits the pressure post.
7. Provide a drip leg in the gas piping near the gas duct furnace. A ground joint union and a manual gas shutoff valve should be installed ahead of the unit heater controls to permit servicing. The manual shutoff valve must be located external to the jacket (See Figure 6).
8. Make certain that all connections have been adequately doped and tightened.

▲ CAUTION Do not over tighten the inlet gas piping into the valve. This may cause stresses that will crack the valve!

NOTICE: Use pipe joint sealant resistant to the action of liquefied petroleum gases regardless of gas connected.

▲ WARNING Check all pipe joints for leakage using a soap solution or other approved method. Never use an open flame or severe personal injury or death may occur!

INSTALLATION (continued)

Figure 6 - Pipe Installation, Standard Controls

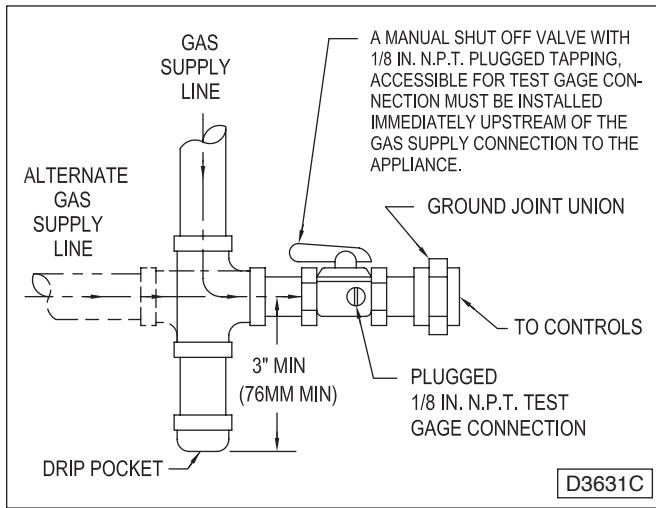

▲ WARNING Never use an open flame to detect gas leaks. Explosive conditions may exist which may result in personal injury or death!

The appliance and its individual shutoff valve must be disconnected from the gas supply piping system during any pressure testing of that system in excess of 1/2 psig (3.5 kPa).

The appliance must be isolated from the gas supply piping system by closing its individual manual shutoff valve during any pressure testing of the gas supply piping system at test pressures equal to or less than 1/2 psig (3.5 kPa).

Table 5 - Gas Supply Pressure*

		Natural Gas	Propane Gas
Heating Value		1,050 BTU/Ft ³	2,500 BTU/Ft ³
		(39.1 MJ/m ³)	(93.1 MJ/m ³)
Manifold Pressure			
Single Stage Application	(in. W.C.)	3.5	10
	(kPa)	(0.87)	(2.49)
Two Stage Application - High Fire	(in. W.C.)	3.5	10
	(kPa)	(0.87)	(2.49)
Two Stage Application - Low Fire	(in. W.C.)	1.1	3.8
	(kPa)	(0.27)	(0.95)
Modulating Application - High Fire (from mod. valve)	(in. W.C.)	4.9	10.6
	(kPa)	(1.22)	(2.64)
Modulating Application - High Fire (from single stg. valve)	(in. W.C.)	3.5	10
	(kPa)	(0.87)	(2.49)
Modulating Application - Low Fire (from mod. Valve)	(in. W.C.)	1.6	3.5
	(kPa)	(0.40)	(0.87)
Modulating Application - Low Fire (from single stg. valve)	(in. W.C.)	0.9	2.8
	(kPa)	(0.22)	(0.70)
Minimum Supply Pressure			
Single Stage Application	(in. W.C.)	5	11
	(kPa)	(1.24)	(2.74)
Two Stage Application	(in. W.C.)	6.5	11.5
	(kPa)	(1.62)	(2.86)
Modulating Application	(in. W.C.)	6.5	11.5
	(kPa)	(1.62)	(2.86)
Maximum Supply Pressure			
		(in. W.C.)	14
		(kPa)	(3.49)

* Applicable for units installed at or below 2,000 feet (610m) altitude. See High Altitude Deration information for altitudes greater than 2,000 feet (610m).

ELECTRICAL CONNECTIONS



▲ WARNING

HAZARDOUS VOLTAGE!
DISCONNECT ALL ELECTRIC POWER INCLUDING REMOTE DISCONNECTS BEFORE SERVICING. Failure to disconnect power before servicing can cause severe personal injury or death.

Standard units are shipped for use on 115 volt, 60 hertz, single phase electric power. The duct furnace data plate and electrical rating of the transformer should be checked before energizing the duct furnace electrical system. All external wiring must conform to the latest edition of ANSI/NFPA No. 70, United States National Electrical Code, and applicable local codes; in Canada, to the Canadian Electrical Code, Part 1, CSA Standard C22.1.

▲ CAUTION Do not use any tools (i.e. screwdriver, pliers, etc.) across terminals to check for power. Use a voltmeter. Failure to do so may result in personal injury or property damage.

▲ CAUTION *USE COPPER CONDUCTORS ONLY!* UNIT TERMINALS ARE NOT DESIGNED TO ACCEPT OTHER TYPES OF CONDUCTORS. Failure to do so may cause damage to the equipment.

It is recommended that the electrical power supply to each duct furnace be provided by a separate, fused, and permanently live electrical circuit. A disconnect switch of suitable electrical rating should be located as close to the gas valve and controls as possible. Each duct furnace must be electrically grounded in accordance with the latest edition of the United States National Electrical Code, ANSI/NFPA No. 70, or CSA Standard C22.1. Refer to Figures 7a, 7b, 7c, 7d, 7e, 7f, and 7g.

THERMOSTAT WIRING AND LOCATION:

NOTICE: The thermostat must be mounted on a vertical, vibration-free surface, free from air currents, and in accordance with the furnished instructions.

Mount the thermostat approximately 5 feet (1.5m) above the floor, in an area where it will be exposed to a free circulation of average temperature air. Always refer to the thermostat instructions, as well as the duct furnace wiring diagram, and wire accordingly. Avoid mounting the thermostat in the following locations:

1. Cold Areas – Outside walls or areas where drafts may affect the operation of the control.
2. Hot Areas – Areas where the sun's rays, radiation, or warm air currents may affect the operation of the control.
3. Dead Areas – Areas where the air cannot circulate freely, such as behind doors or in corners.

Figure 7a - Low-voltage Thermostat Wiring Single Stage

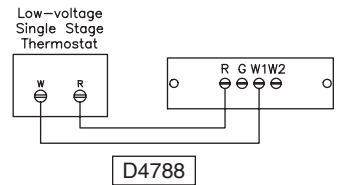

Figure 7b - Low-voltage Thermostat Wiring Two Stage

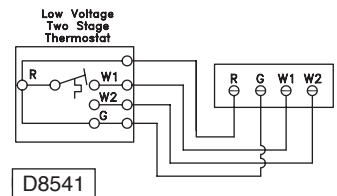
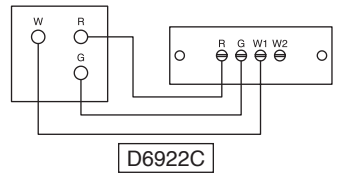

Figure 7c - Low-voltage T834H, T834N (or equivalent) Thermostat Wiring Single Stage



NOTICE: The start-up fan delay should not exceed 30 seconds from a cold start.

IMPORTANT: For all wiring connections, refer to the wiring diagram shipped with your unit (either affixed to the inside of the control access panel or enclosed in the installation instructions envelope). Should any original wire supplied with the unit have to be replaced including high limit wires, it must be replaced with wiring material having a temperature rating of at least 105°C.

Standard single stage and optional two stage wiring diagrams are included in this manual. Duct furnaces equipped with modulating gas controls and other optional equipment will be shipped with a unit-specific wiring diagram.

ELECTRICAL CONNECTIONS (continued)

Figure 7d – Tubular Duct Furnaces Equipped with Natural Gas or Propane (LP) Gas, Single Stage

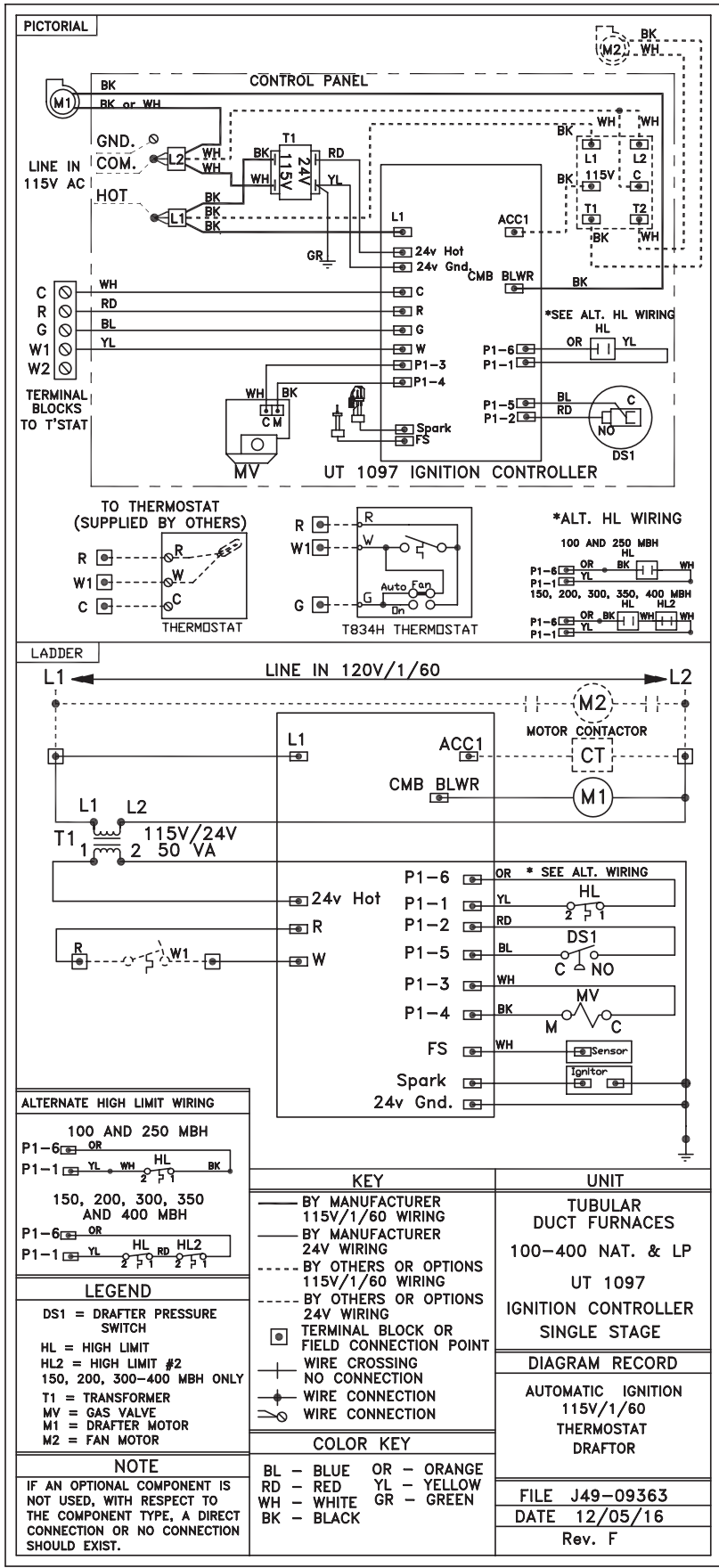

ELECTRICAL CONNECTIONS (continued)

Figure 7e - Tubular Duct Furnaces Equipped with Natural Gas or Propane (LP) Gas, Two Stage

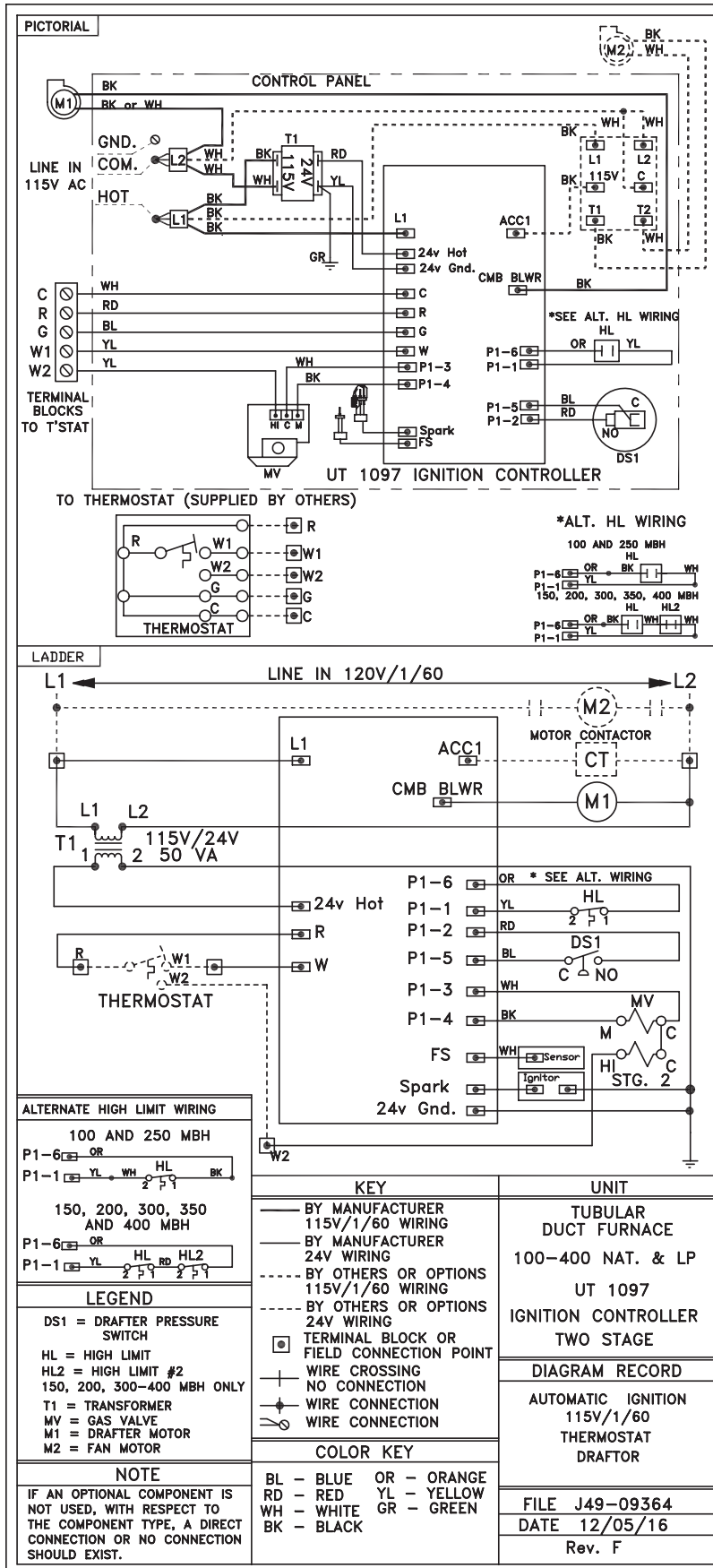

VENTING

NOTICE: All vertical and horizontal venting arrangements for Tubular Duct Furnaces are Category III venting.

ANSI now organizes vented appliances into four categories.

Venting Categories

	Non Condensing	Condensing
Negative Vent Pressure	I	II
Positive Vent Pressure	III	IV

Category I

Includes non-condensing appliances with negative vent pressure, like the traditional atmospheric unit heater.

Category III

Appliances are non-condensing and operate with a positive vent pressure.

Category II

Groups condensing appliances with negative vent pressure.

Category IV

Covers condensing appliances with positive vent pressure.

All duct furnaces must be vented! All venting installations shall be in accordance with the latest edition of Part 7, Venting of Equipment of the National Fuel Gas Code, ANSI Z223.1 (NFPA 54), or applicable provisions of local building codes. Refer to Figures 8A, 8B, 9A, 9B, 10A, 10B, 11A, and 11B. For installations in Canada, see page 16.

▲ WARNING CARBON MONOXIDE! Your venting system must not be blocked by any snow, snow drifts, or any foreign matter. Inspect your venting system to ensure adequate ventilation exists at all times! Failure to heed these warnings could result in Carbon Monoxide Poisoning (symptoms include grogginess, lethargy, inappropriate tiredness, or flu-like symptoms).

Do not damper or add heat recovery devices to the flue piping. Failure to open such a damper prior to operating gas unit will result in the spillage of flue gas into the occupied space.

VENTING FOR POWER VENTED DUCT FURNACES (CATEGORY III)

ALL DUCT FURNACES MUST BE VENTED! All venting installations shall be in accordance with the latest edition of Part 7, Venting of Equipment of the National Fuel Gas Code, ANSI Z223.1, or applicable provisions of local building codes for power vented units. Also see page 16 for additional Canadian installation information.

Vent pipe material must be in compliance with UL 1738 for installations in the United States, and UL S636 for installations in Canada.

Refer to Table 6 for vent termination clearance requirements.

Through the wall vents for these appliances shall NOT terminate over public walkways, or over an area where condensate or vapor could create a nuisance or hazard or could be detrimental to the operation of regulators, relief valves, or other equipment.

The vent pipe equivalent length must be 5 feet (1.5m) minimum and must not exceed 50 feet (15.2m). Equivalent length is the total length of straight sections PLUS 10 feet (3.05m) for each 90 degree elbow, and 4 feet (1.22m) for each 45 degree elbow.

Maintain 6 inch (152mm) between vent pipe and combustible materials. A minimum of 12 inch (305mm) of straight pipe is required from the venter outlet before installing an elbow in the vent system. **An elbow should never be attached directly to the venter!**

▲ WARNING Never use a pipe of a diameter other than that specified in Table 1! Never use PVC or other nonmetallic pipe for venting! To do so may result in serious damage to the unit, severe personal injury, or death.

Any run of single wall vent pipe exposed to cold air or passing through an unheated indoor space must be insulated with insulation suitable to 550°F (288°C).

The vent system must be installed to prevent collection of condensate. Vertical vent pipes should be equipped with condensate drains. Pitch horizontal pipes downward 1/4 inch per foot (21mm/m) toward outlet for condensate drainage.

VENTING (continued)

VENTING FOR POWER VENTED DUCT FURNACES (CATEGORY III) (continued)

Horizontal portions of the venting system shall be supported at maximum intervals of 4 feet (1.2m) to prevent sagging. In Canada, support at a maximum of 3 feet (1m) intervals.

Each unit must have an individual vent pipe and vent terminal per furnace section! Each unit MUST NOT be connected to other vent systems or to a chimney.

Table 6

Vent Systems Termination Clearance Requirements		
Structure/Object	Minimum Clearance for Termination Locations	
	USA	CANADA
Door, window, or gravity vent inlet; combustion air inlet for other appliances	9 inch for 10,000 to 50,000 BTU/Hr input; 12 inch for input exceeding 50,000 BTU/Hr.	9 inch (230mm) for 10,000 to 50,000 BTU/Hr input; 12 inch (305mm) for input exceeding 50,000 BTU/Hr.
Forced air inlet within 10 feet	3 feet above	6 feet (1.8m)
Adjoining Building or parapet	10 feet	10 feet (3.04m)
Adjacent public walkways	7 feet above grade	7 feet (2.1m) above grade
Electric, gas meters & regulators	4 feet horizontal	3 feet (0.9m) horizontally from meter/regulator assembly. 6 feet (1.8m), any direction, from a gas service regulator vent outlet
Above grade level*	1 foot	1 foot (0.3m)

*Minimum above maximum snow depth, or per local code, whichever is greater.

ADDITIONAL REQUIREMENTS FOR CANADIAN INSTALLATIONS

REFER TO SPECIFICATION TABLE AND INSTALLATION MANUAL FOR PROPER USAGE

The following instructions apply to Canadian installations in addition to installation and operating instructions.

1. Installation must conform with local building codes, or in the absence of local codes, with current CSA-B149.1, Installation Codes for Natural Gas Burning Appliances and Equipment, or CSA-B149.2, Installation Codes for Propane Gas Burning Appliances and Equipment.
2. Any reference to U.S. standards or codes in these instructions are to be ignored, and the applicable Canadian standards or codes applied.

VENTING (continued)

VERTICALLY VENTED DUCT FURNACES (CATEGORY III)

Observe the following precautions when venting the unit:

1. Use flue pipe of the same size as the flue connections on the gas duct furnace (See Table 1). All heaters should be vented with UL Listed (UL 1738 in United States, UL S636 in Canada) double wall or single wall vent pipe.
2. Provide as long a vertical run of flue pipe at the duct furnace as possible. A minimum of 5 feet (1.5m) of vertical flue is required. The top of the vent pipe should extend at least 2 feet (0.61m) above the highest point on the roof within 10 feet (3.05m) of the termination. Install a weather cap over the vent opening; cap should be a Breidert Type L or Fields Starkap vent cap. Consideration should be made for anticipated snow depth. See Figure 8A.
3. Slope horizontal runs upward from the duct furnace at least 1/4 inch per foot (21mm/m) minimum. Horizontal runs should not exceed 75% of the vertical height of the vent pipe above the flue pipe connections, up to a maximum length of 10 feet (3m). Horizontal portions of the venting system shall be supported at minimum intervals of 4 feet (1.2m) in the United States, and at minimum intervals of 3 feet (1m) in Canada. See Figure 8A.
4. Use as few elbows as possible.
5. Avoid running vent pipe through unheated indoor spaces.
6. When this cannot be avoided, insulate the pipe to prevent condensation of moisture on the walls of the pipe.
7. Do not damper the flue piping. Failure to open such damper prior to operating the duct furnace will result in the spillage of flue gas into the occupied space.
8. Avoid installing units in areas under negative pressure due to large exhaust fans or air conditioning. When required, a flue vent fan should be installed in accordance with the instructions included with the fan.
9. Vent connectors serving Category I and Category II heaters shall not be connected into any portion of mechanical draft systems operating under positive pressure.

VENTING (continued)

HORIZONTALLY VENTED DUCT FURNACES (CATEGORY III)

Observe the following precautions when venting the unit:

1. Horizontal venting arrangements are designed to be used with single wall or double wall vent pipe. Horizontal venting arrangements must terminate external to the building using UL 1738 vent pipe in the United States. For installations in Canada, use vent pipe conforming with UL S636, local building codes, or in the absence of local building codes, with current CSA-B149.1 Installation Codes for Natural Gas Burning Appliances and Equipment, or CSA-B149.2 Installation Codes for Propane Gas Burning Appliances and Equipment.

▲ WARNING Do not use Type B (double wall) vent internally within the building on power vented units that are vented horizontally.

NOTICE: For Canada only – where allowed by code, appropriately sealed 26-gauge or heavier galvanized steel or equivalent single-wall pipe may be used.

2. Single wall and double wall venting components which are UL Listed and approved for Category III positive pressure venting systems MUST be used.
3. A Breidert Type L or Fields Starkap vent cap must be supplied by the customer for each power vented unit. The vent pipe diameter MUST be as specified in Table 1 ("F" Flue Size Diameter). All unit sizes are factory equipped with the required flue size collar.
4. The vent terminal must be at least 12 inches (305mm) from the exterior of the wall that it passes through to prevent degradation of the building material by flue gases. Minimum and maximum wall thickness for the venting system consist of 4-1/4 inch (105mm) to 8-1/2 inch (216mm) for 5 inch (127mm) diameter vent pipe and 5-3/4 inch (146mm) to 11-1/2 inches (292mm) on 6 inch (152mm) vent pipe.
5. Through the wall vent for these appliances shall NOT terminate over public walkways, or over an area where the condensate or vapor could create a nuisance or hazard, or could be detrimental to the operation of regulators, relief valves, or other equipment. See Figure 8B and Table 6 for vent terminal height and snow consideration requirements.
6. The vent pipe equivalent length must not exceed 50 feet (15.2m). Equivalent length is the total length of straight sections PLUS 10 feet (3.05m) for each 90 degree elbow and 4 feet (1.22m) for each 45 degree elbow.
7. Maintain clearance between the vent pipe and combustible materials in accordance with the vent pipe manufacturer's instructions.
8. The vent system must be installed to prevent collection of condensate. Pitch horizontal portions of vent pipe downward 1/4 inch per foot (21mm/m) toward the outlet for condensate drainage. See Figure 8B.
9. Horizontal portions of the venting system shall be supported at maximum intervals of 4 feet (1.2m) in the United States, and at minimum intervals of 3 feet (1m) in Canada.
10. Insulate single wall vent pipes exposed to cold air or running through unheated indoor areas.
11. Each unit must have an individual vent pipe and vent terminal! Each unit MUST NOT be connected to other vent systems.

VENTING (continued)

Figure 8A - Vertically Vented Category III, Standard Combustion

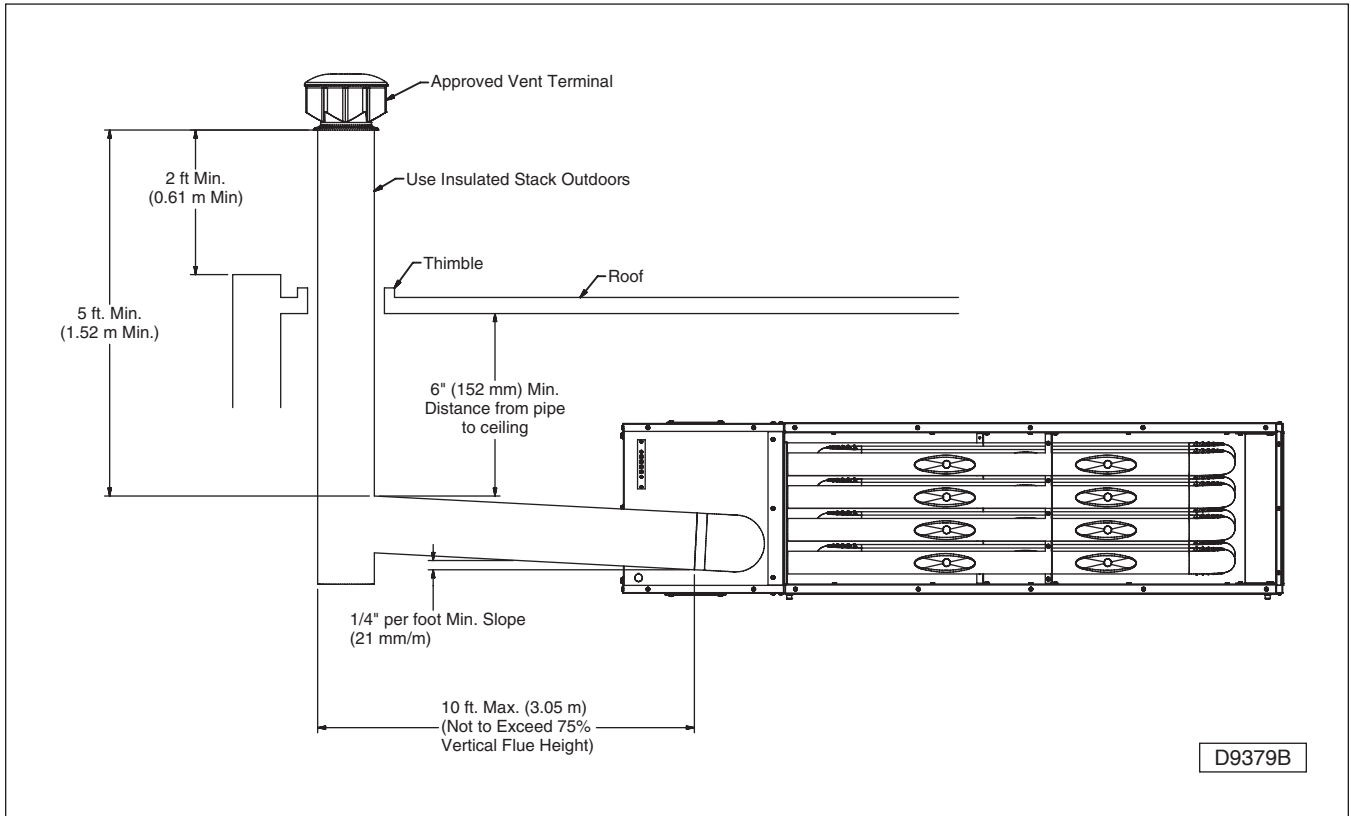
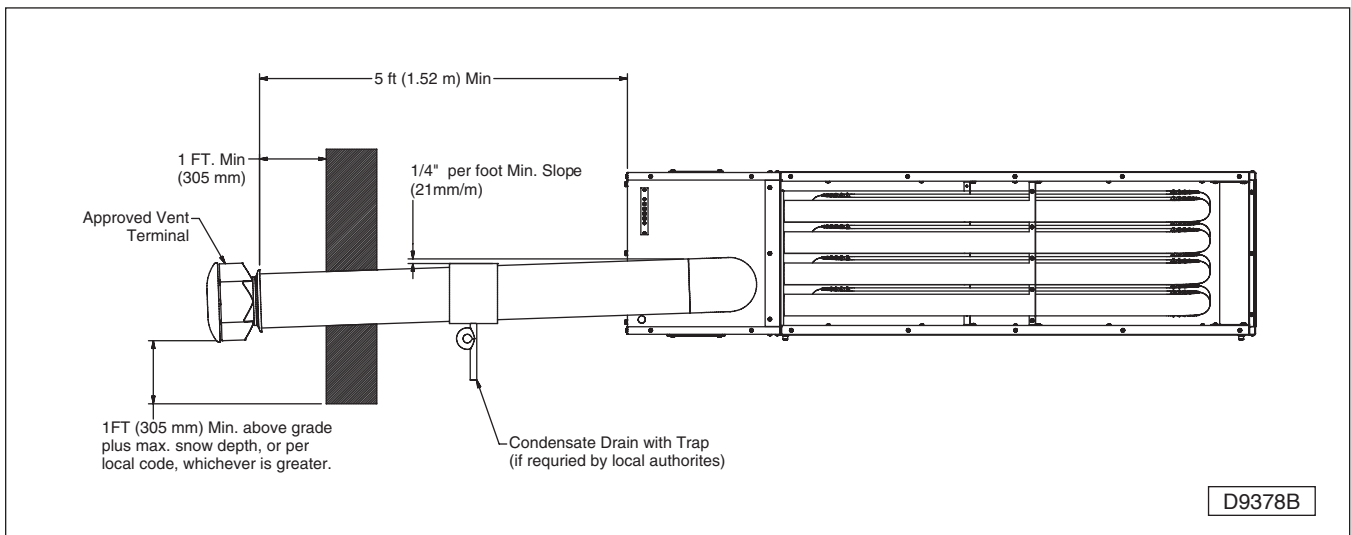

Figure 8B - Horizontally Vented Category III, Standard Combustion



VENTING (continued)

NOTICE: Combustion and exhaust venting instructions below describe two-pipe venting of a duct furnace configured for separated combustion. If converting the duct furnace to separated combustion, an Air Inlet Kit (X9) is required and instructions included with the kit must be followed to complete the conversion process. If venting a separated combustion duct furnace concentrically (through one roof or wall termination), a Combustion Air Inlet Kit (X8) is required and instructions included with the kit should be followed with regards to vent pipe installation. Both kits are available from the manufacturer.

COMBUSTION AIR VENTING AND PIPING

▲ WARNING Never operate separated combustion duct furnaces without combustion air and flue gas piping in place or severe personal injury or death may occur!

▲ WARNING **CARBON MONOXIDE!** Your venting system must not be blocked by any snow, snow drifts, or any foreign matter. Inspect your venting system to ensure adequate ventilation exists at all times! Failure to heed these warnings could result in Carbon Monoxide Poisoning (symptoms include grogginess, lethargy, inappropriate tiredness, or flu-like symptoms).

1. In the United States, the combustion air system installation must be in accordance with the latest edition of ANSI Z223.1 (NFPA 54) National Fuel Gas Code. In Canada, installation must be in accordance with CSA-B149.1 "Installation Code for Natural Gas Burning Appliances and Equipment" and CSA-B149.2 "Installation Code for Propane Burning Appliances and Equipment."
2. A Breidert Type L or Fields Starkap, furnished by the customer, must be installed at the termination point of the combustion air system. See Figures 9A and 9B.
3. Each duct furnace MUST have its own combustion air system. It MUST NOT be connected to other air intake systems.
4. Use UL 1738 listed single wall pipe for the vent system. For installations in Canada, use UL S636 listed vent pipe conforming with local building codes, or in the absence of local building codes, with current CSA-B149.1 "Installation Codes for Natural Gas Burning Appliances and Equipment" or CSA-B149.2, "Installation Codes for Propane Gas Burning Appliances and Equipment."

▲ WARNING Never use pipe of a diameter other than that specified in Table 1! Never use PVC, ABS or any other non-metallic pipe for venting! To do so may result in serious damage to the unit and/or severe personal injury or death!

5. Long runs of single wall combustion air piping passing through an unheated space may require insulating if condensation becomes noticeable.
6. The combustion air system must be installed to prevent collection of condensate. Pitch horizontal pipes downward 1/4 inch per foot (21mm/m) toward the inlet cap to facilitate drainage. Vertical combustion air pipes should be piped as depicted in Figure 9A.
7. The equivalent length of the combustion air system must not be less than 5 feet (1.5m) and must not exceed 50 feet (15.2m), excluding flue vent pipe. Equivalent length equals the total length of straight pipe, plus 10 feet (3.05m) for each 90° elbow and 4 feet (1.22m) for each 45° elbow.

NOTICE: For optimum performance keep the combustion air system as straight as possible.

8. Each slip joint must be secured with at least three corrosion resistant screws. Two full turns of 3M #425 Aluminum Foil Tape or its equivalent must then be used to seal each joint. General Electric RTV-108, Dow-Corning RTV-732 or an equivalent may be used instead of tape.
9. For horizontal combustion air systems longer than 5 feet (1.5m), the system must be supported from overhead building structures at 4 feet (1.22m) maximum intervals in the United States and at 3 feet (1m) maximum intervals in Canada.

VENTING (continued)

EXHAUST VENTING

▲ WARNING Never operate separated combustion duct furnaces without combustion air and flue gas piping in place or severe personal injury or death may occur!

▲ WARNING CARBON MONOXIDE! Your venting system must not be blocked by any snow, snow drifts, or any foreign matter. Inspect your venting system to ensure adequate ventilation exists at all times! Failure to heed these warnings could result in Carbon Monoxide Poisoning (symptoms include grogginess, lethargy, inappropriate tiredness, or flu-like symptoms).

1. In the United States, vent system installation must be in accordance with the latest edition of ANSI Z223.1 (NFPA 54) National Fuel Gas Code. In Canada, installation must be in accordance with CSA-B149.1 "Installation Code for Natural Gas Burning Appliances and Equipment" and CSA-B149.2 "Installation Code for Propane Burning Appliances and Equipment."
2. A Breidert Type L or Fields Starkap, furnished by the customer, must be installed at the termination point of the vent system. See Figures 9A and 9B.
3. Each duct furnace MUST have its own vent system. It MUST NOT be connected to other vent systems or to a chimney.
4. Use UL 1738 listed single wall pipe for the vent system. For installations in Canada, use UL S636 listed vent pipe conforming with local building codes, or in the absence of local building codes, with current CSA-B149.1 "Installation Codes for Natural Gas Burning Appliances and Equipment" or CSA-B149.2, "Installation Codes for Propane Gas Burning Appliances and Equipment."

▲ WARNING Never use pipe of a diameter other than that specified in Table 1! Never use PVC, ABS, or any other non-metallic pipe for venting! To do so may result in serious damage to the unit and/or severe personal injury or death!

5. Any run of single wall vent pipe passing through an unheated space must be insulated with an insulation suitable to 550°F (288°C).
6. The vent system must be installed to prevent collection of condensate. Pitch horizontal pipes downward 1/4 inch per foot (21mm/m) towards the vent cap to facilitate drainage. Vertical vent pipes should be piped as depicted in Figure 9A.
7. The equivalent length of the flue vent system must not be less than 5 feet (1.5m) and must not exceed 50 feet (15.2m), excluding combustion air pipe. Equivalent length equals the total length of straight pipe plus 10 feet (3.05m) for each 90 degree elbow and 4 feet (1.22m) for each 45 degree elbow.
8. For horizontal combustion air systems longer than 5 feet (1.5m), the system must be supported from overheard building structures at 4 feet (1.22m) maximum intervals in the United States and at 3 feet (1m) maximum intervals in Canada.
9. The exhaust vent system must remain at a minimum distance of 6 inch (152mm) from all combustible materials. Any part of the vent system that passes through a combustible material must be properly insulated.

NOTICE: Increasing the clearance distances may be necessary if there is a possibility of distortion or discoloration of adjacent materials.

For a VERTICAL vent pipe section that passes through a floor or roof, an opening 4 inch (102mm) greater in diameter is required. The opening must be insulated and flashed in accordance with applicable installation codes. Also see Figures 10A and 11A.

A HORIZONTAL section of an exhaust vent system that passes through a combustible wall must be constructed and insulated as shown in Figures 10B and 11B.

VENTING (continued)

Figure 9A - Vertical Inlet/Vent Locations, Separated Combustion

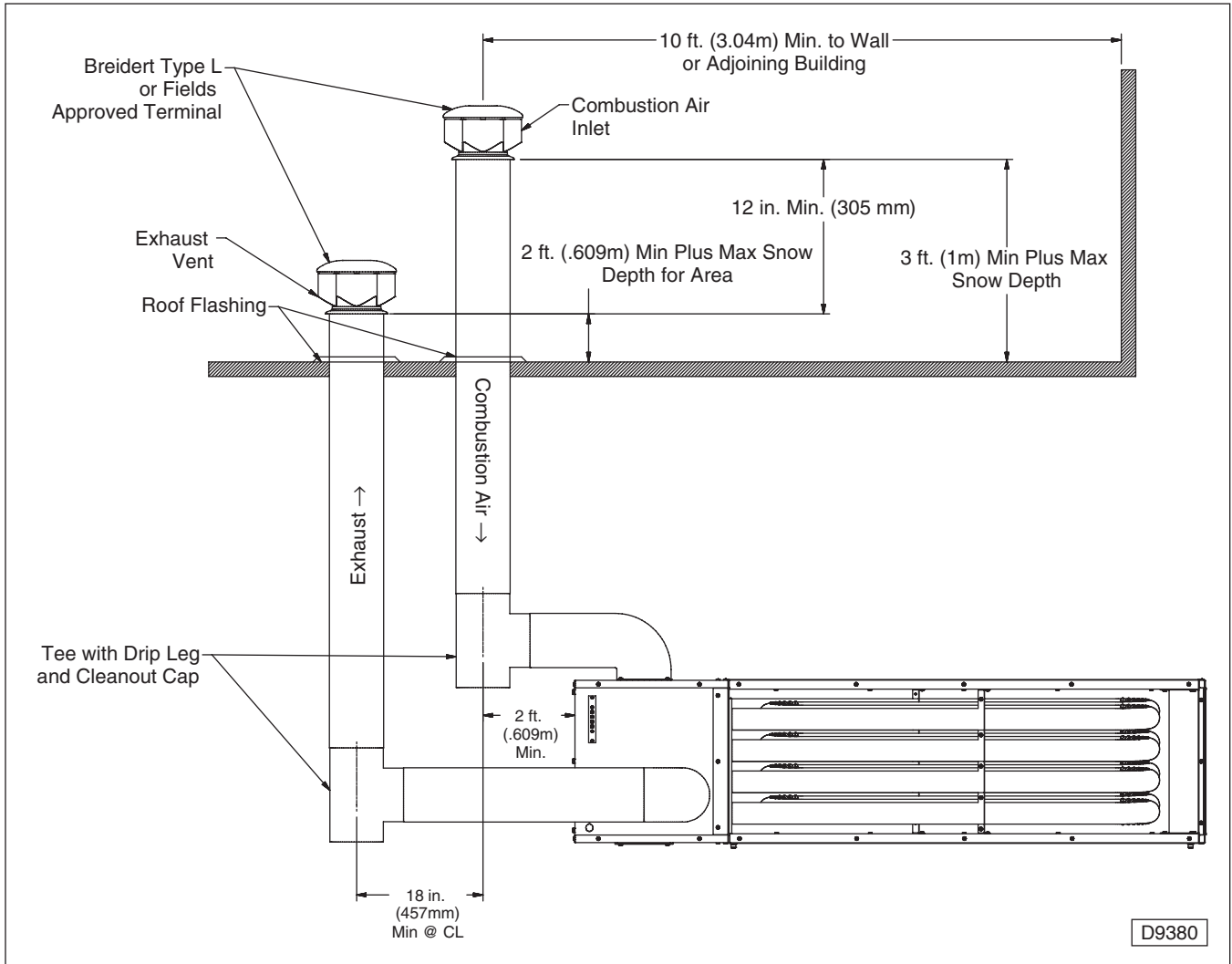
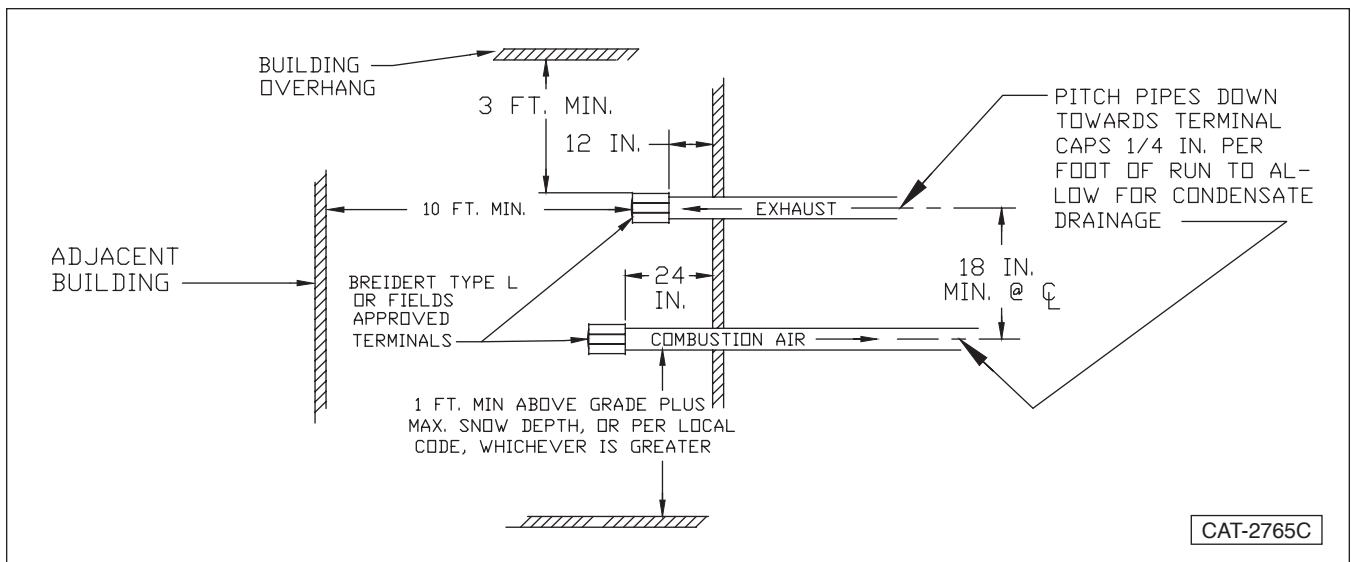

Figure 9B - Horizontal Inlet/Vent Locations, Separated Combustion



VENTING (continued)

Figure 10A - Vertical Arrangement, Single Wall Vent System to Single Wall Termination

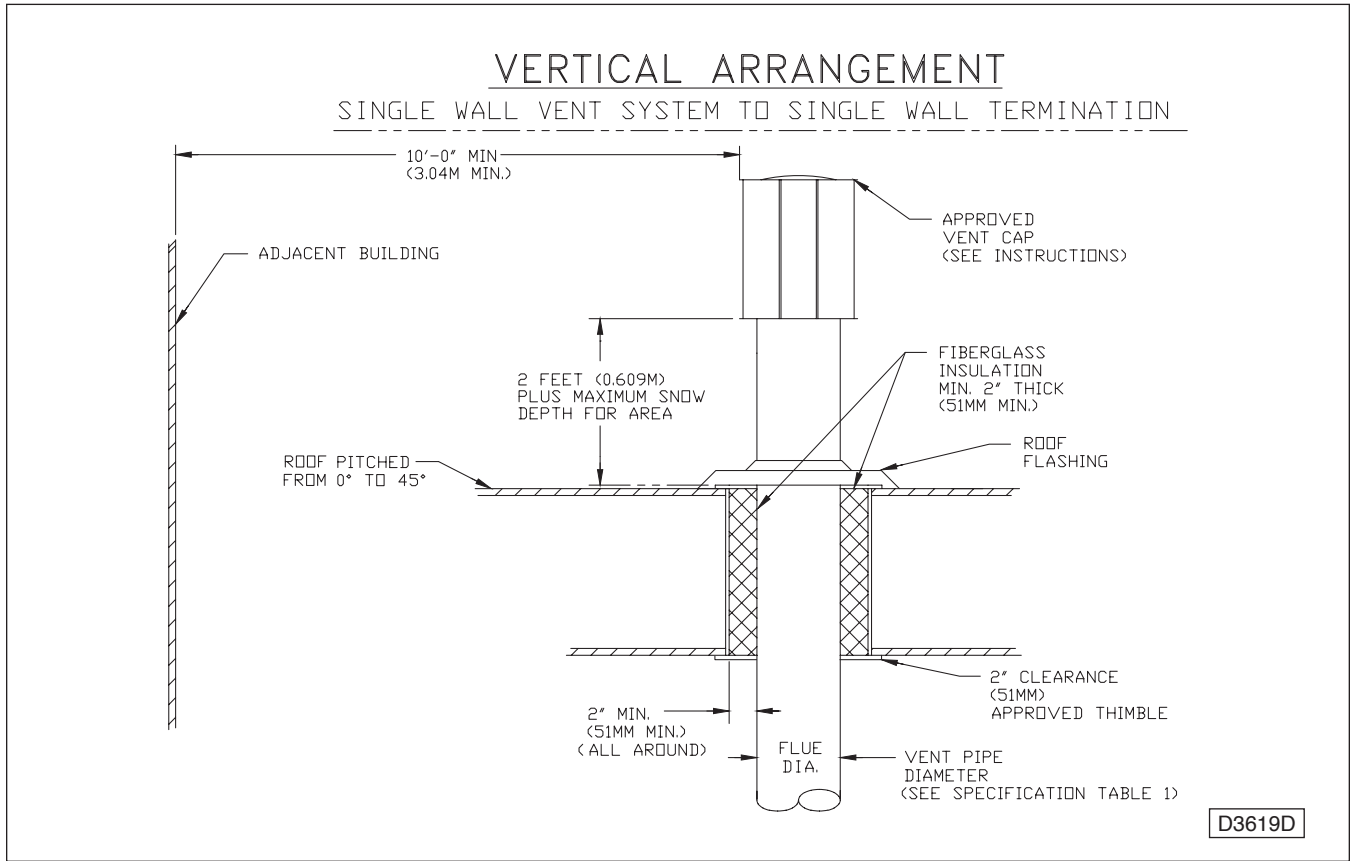
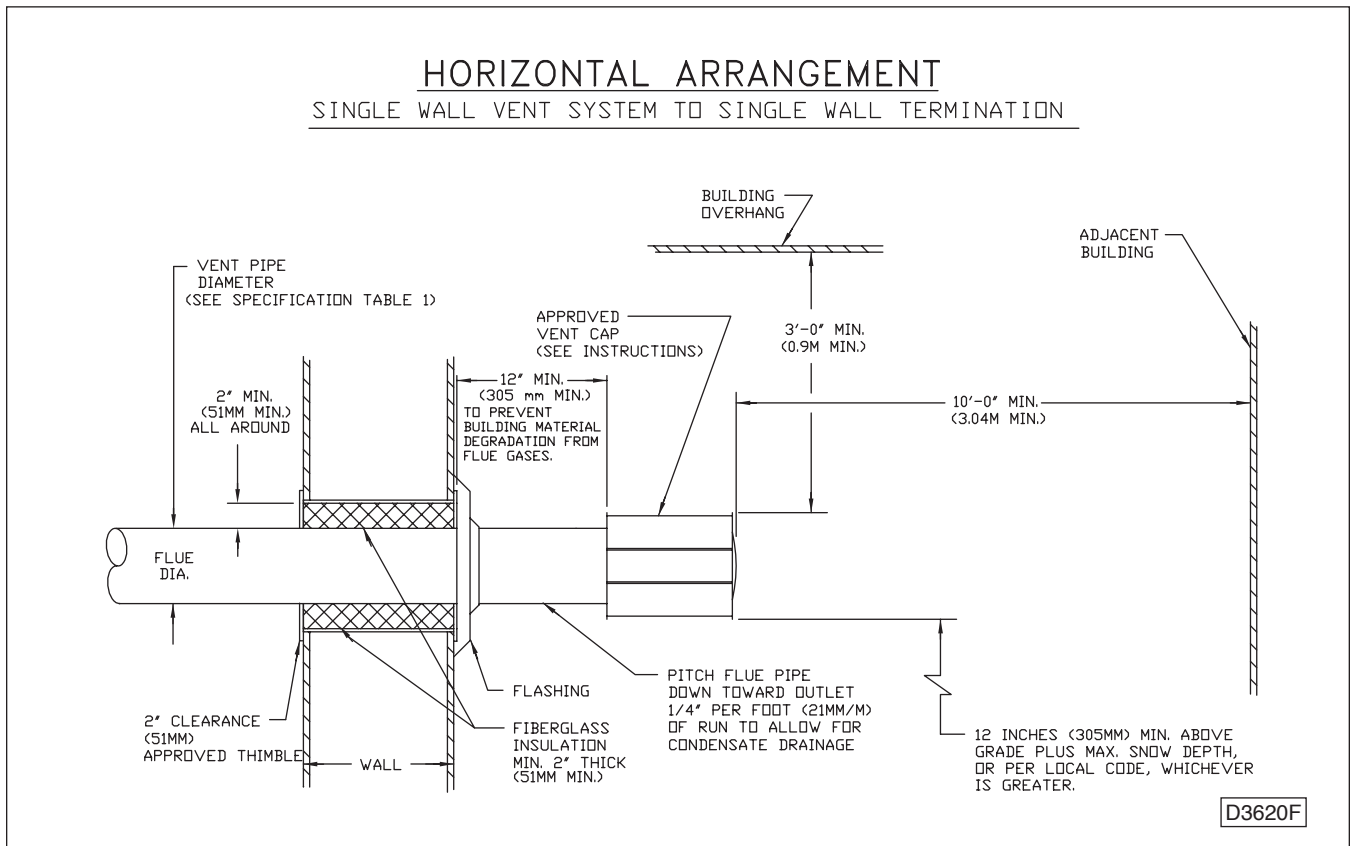

Figure 10B - Horizontal Arrangement, Single Wall Vent System to Single Wall Termination



VENTING (continued)

Figure 11A - Vertical Arrangement, Single Wall Vent System to Double Wall Termination

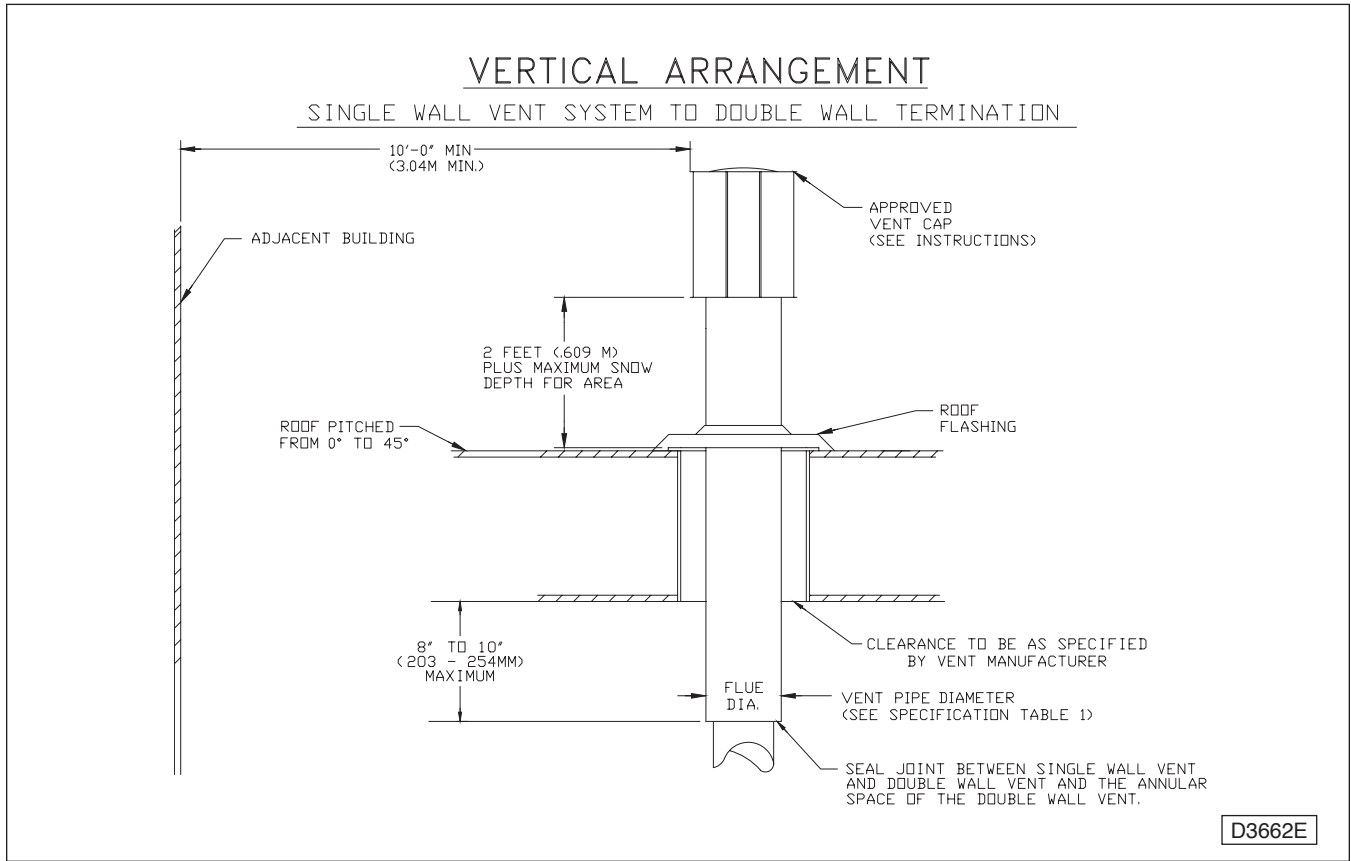
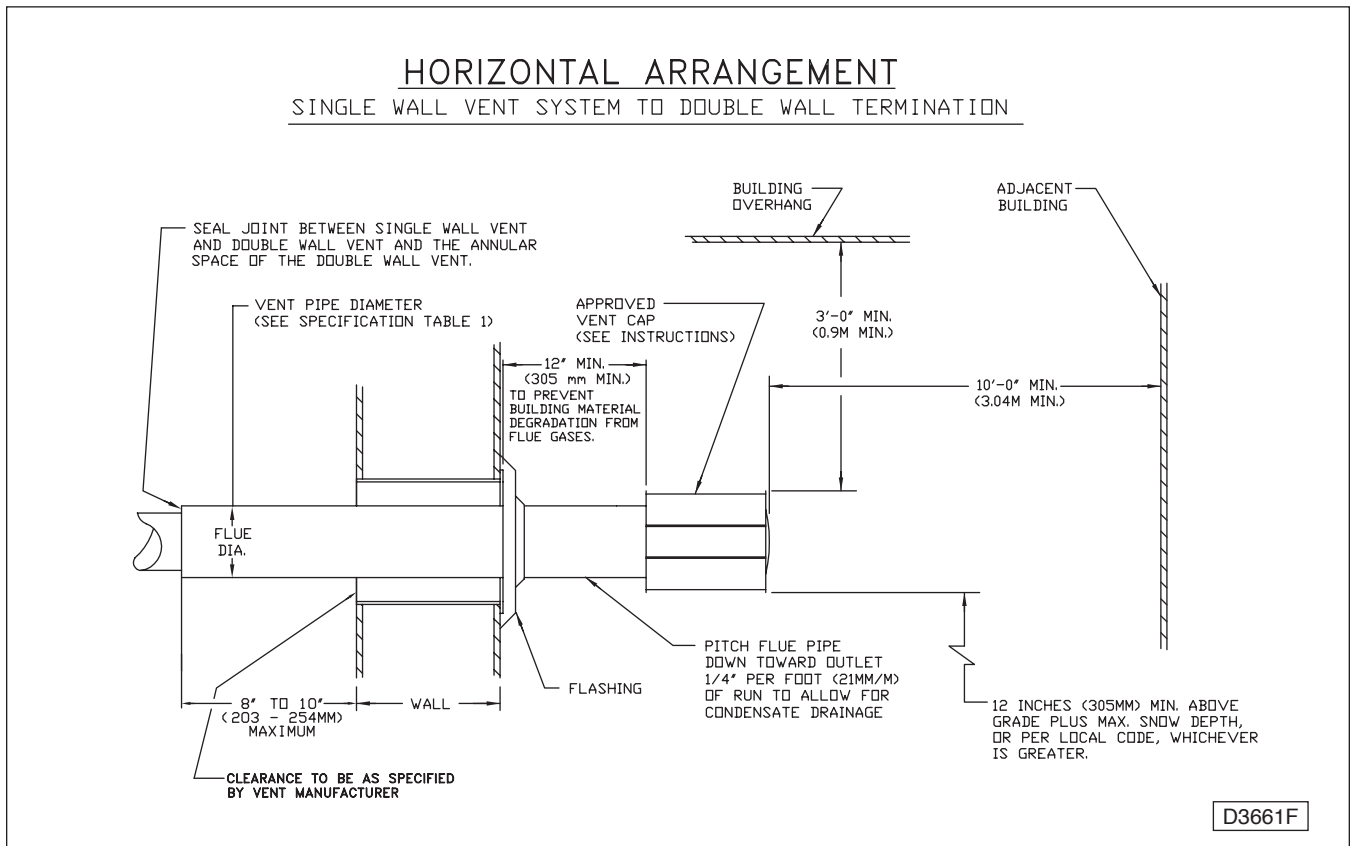

Figure 11B - Horizontal Arrangement, Single Wall Vent System to Double Wall Termination



OPERATION

TUBULAR DUCT FURNACE DIRECT SPARK IGNITION

EXPLANATION OF CONTROLS:

1. The duct furnace is equipped with a power vent system that consists of a power vent motor and blower, pressure switch, and sealed flue collector in place of a conventional gravity vent draft diverter.
2. The power vent motor is energized by the room thermostat through the integrated control board when a demand for heat is sensed. The pressure switch measures the flow through the vent system and energizes the direct spark ignition system, beginning the pre-purge timing when the flow is correct.

▲ WARNING The pressure switch **MUST NOT** be bypassed. The duct furnace **MUST NOT** be fired unless the power vent system is operating. An unsafe condition could result.

3. The direct spark ignition system consists of an integrated control board, a spark ignitor, a flame sensor, and a gas valve. When the pre-purge period ends, the direct spark ignition system is energized, and the gas valve opens to supply gas to the burners. When the thermostat is satisfied, the vent system is de-energized and the gas valve closes to stop the flow of gas to the unit. (See Figure 12.)
4. The high limit switch interrupts the flow of electric current to the control board if the duct furnace becomes overheated, interrupting the flow of gas to the gas valve. The duct furnace will begin a post-purge period. When the post-purge period ends, the power vent motor is de-energized.
5. Once the thermostat is satisfied, the duct furnace will begin a post-purge period. When the post-purge period ends, the power vent motor is de-energized.
6. The wall thermostat, supplied optionally, is a temperature sensitive switch that operates the power vent and direct spark ignition system to control the temperature of the space being heated. The thermostat must be mounted on a vertical, vibration-free surface free of air currents and in accordance with the furnished instructions (also refer to Electrical Connections section of this manual).

START-UP (Also refer to lighting instruction plate equipped on the unit)

1. Open the manual gas valve in the gas supply line to the duct furnace. Loosen the union in the gas line to purge it of air. Tighten the union and check for leaks.

▲ WARNING Never use an open flame to detect gas leaks. Explosive conditions may exist which could result in personal injury or death.

2. Open the supply gas valve on the duct furnace.
3. Turn ON the electrical power.
4. Turn on system fan (provided by others).

NOTICE: Failure to turn on system fan when duct furnace is running will cause the unit to trip on high limit. This may result in damage to the duct furnace and heat exchanger.

5. The unit should be under the control of the thermostat. Turn the thermostat to the highest point and determine that the power vent motor starts and the burners ignite. Turn the thermostat to the lowest point and determine that the power vent motor shuts off and the burners are extinguished.
6. Turn the thermostat to the desired position.
7. See Gas Input Rate section.

SHUT DOWN

1. Turn the supply gas valve selector to the OFF position.
2. Turn off the electricity.
3. To relight, follow "START-UP" instructions.

See Figures 12 and 13 for parts identification.

Figure 12 - Direct Spark Ignition System, Tubular Duct Furnace

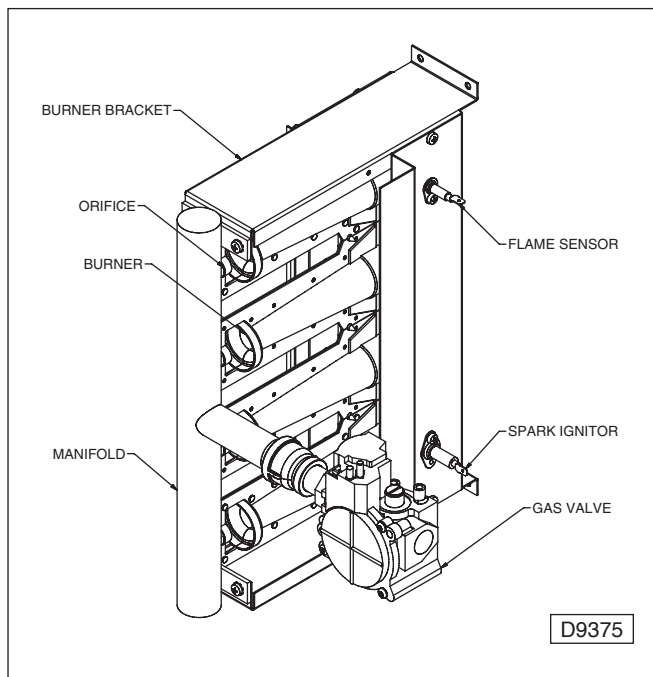

OPERATION (continued)

GAS INPUT RATE

Check the gas input rate as follows (Refer to General Safety Information section for metric conversions).

▲ CAUTION Never over-fire the duct furnace, as this may cause unsatisfactory operation, or shorten the life of the heater.

1. Turn off all gas appliances that use gas through the same meter as the duct furnace.
2. Turn the gas on to the duct furnace.
3. Clock the time in seconds required to burn 1 cubic foot of gas by checking the gas meter.
4. Insert the time required to burn 1 cubic foot of gas into the following formula and compute the input rate:

$$\frac{3600 \text{ (Sec. per Hr.)} \times \text{BTU/Cu.Ft.}}{\text{Time (Sec.)}} = \text{Input Rate}$$

For example:

Assume the BTU content of one cubic foot of gas is 1000, and that it takes 18 seconds to burn one cubic foot of gas.

$$\frac{3600 \times 1000}{18} = 200,000$$

NOTICE: If the computation exceeds, or is less than 95% of the gas BTU/Hr. input rating (see Table 2), adjust the gas pressure.

Adjust the gas manifold pressure as follows:

1. **NATURAL GAS:** Best results are obtained when the duct furnace is operating at its full rated input with a manifold pressure of 3.5 inch WC (0.9kPa). Adjustment of the pressure regulator is not normally necessary since it is preset at the factory. However, field adjustment may be made as follows:
 - a. Attach manometer at the pressure tap plug adjacent to the control outlet.
 - b. Remove the regulator adjustment screw cap, located on the combination gas valve.
 - c. With a small screwdriver, rotate the adjustment screw counterclockwise to decrease pressure, or clockwise to increase pressure.
 - d. Replace regulator adjustment screw cap.
2. **PROPANE (LP) GAS:** An exact manifold pressure of 10.0 inch WC (2.5 kPa) must be maintained for proper operation of the duct furnace. If the duct furnace is equipped with a pressure regulator on the combination gas valve, follow steps “a” through “d” above. If the duct furnace is not so equipped, the propane gas supply system pressure must be regulated to attain this manifold operating pressure.

Table 7 - Main Burner Orifice Schedule – Standard Altitude*

INPUT IN 1000 BTU	TYPE OF GAS	NATURAL	PROPANE	NUMBER OF BURNER ORIFICES
	HEATING VALUE	1050 BTU/Ft ³ (39.1 MJ/m ³)	2500 BTU/Ft ³ (93.1 MJ/m ³)	
	MANIFOLD PRESSURE	3.5 INCH WC (0.87kPa)	10 INCH WC (2.49 kPa)	
100	FT ³ /HR	93	40	2
	ORIFICE DRILL	3.40mm	45	
150	FT ³ /HR	140	60	3
	ORIFICE DRILL	3.40mm	45	
200	FT ³ /HR	186	80	4
	ORIFICE DRILL	3.40mm	45	
250	FT ³ /HR	233	100	5
	ORIFICE DRILL	3.40mm	45	
300	FT ³ /HR	280	120	6
	ORIFICE DRILL	3.40mm	45	
350	FT ³ /HR	326	140	7
	ORIFICE DRILL	3.40mm	45	
400	FT ³ /HR	372	140	8
	ORIFICE DRILL	3.40mm	45	

*This schedule is for units at operating at normal altitudes of 2,000 feet (610m) or less.

When installed in Canada, any references to deration at altitudes in excess of 2000 feet (610m) are to be ignored. At altitudes of 2,000 to 4,500 feet (610 to 1372m), the unit must be field derated and be so marked in accordance with ETL certification. See Table 7A for field deration information.

TUBULAR DUCT FURNACE HIGH ALTITUDE DERATION

This Tubular duct furnace has been manufactured utilizing standard burner orifices and a normal manifold pressure setting as per the specifications shown on your unit rating plate.

All unit deration must be done through field adjustments by a qualified technician. Once the proper adjustments are made in the field, attach label #J17-06459 to the unit, and record adjusted manifold pressure, altitude of the unit installation, the technician’s name, and the date on the label using a permanent marker.

Refer to installation instruction section Gas Input Rate for adjusting the manifold pressure.

OPERATION (continued)

Table 7A

High Altitude Deration - United States

Altitude		Manifold Pressure				BTU Output ¹
		Natural Gas ²		Liquid Propane ³		
Feet	Meters	Inches W.C.	Pa	Inches W.C.	Pa	Percentage
0-2,000	0-610	3.5	871	10.0	2,488	100%
2,001-3,000	611-915	3.0	747	8.5	2,115	92%
3,001-4,000	916-1220	2.7	672	7.7	1,916	88%
4,001-5,000	1221-1525	2.5	622	7.1	1,767	84%
5,001-6,000	1526-1830	2.2	547	6.4	1,593	80%
6,001-7,000	1831-2135	2.0	498	5.8	1,443	76%
7001-8000	2136-2440	1.8	448	5.2	1,294	72%
8001-9000	2441-2745	1.6	398	4.6	1,145	68%
9001-10,000	2746-3045	1.4	348	4.1	1,020	64%

- Notes: 1. Deration based on ANSI Z223.1 (NFPA 54).
 2. Table based on heating value of 1,050 BTU/Cu. feet at sea level.
 3. Table based on heating value of 2,500 BTU/Cu. feet at sea level.
 4. Consult local utility for actual heating value.

High Altitude Deration - Canada

Altitude		Manifold Pressure				BTU Output ¹
		Natural Gas ²		Liquid Propane ³		
Feet	Meters	Inches W.C.	Pa	Inches W.C.	Pa	Percentage
0-2,000	0-610	3.5	871	10	2,488	100%
2001-3000	611-915	3.2	796	9.2	2,289	96%
3001-4000	916-1220	2.9	722	8.4	2,090	92%
4001-4500	1221-1371	2.8	697	7.9	1,966	90%

- Notes: 1. Deration based on CGA 2.17-M91
 2. Table based on heating value of 1,050 BTU/Cu. feet at sea level.
 3. Table based on heating value of 2,500 BTU/Cu. feet at sea level.
 4. Consult local utility for actual heating value.

MAINTENANCE

PERIODIC SERVICE

NOTICE: The duct furnace and vent system should be checked once a year by a qualified technician.

All Maintenance/Service information should be recorded accordingly on the Inspection Sheet provided at the end of this manual.

▲ WARNING Open all disconnect switches and disconnect all electrical and gas supplies and secure in that position before servicing unit. Failure to do so may result in personal injury or death from electrical shock.

▲ WARNING Gas tightness of the safety shut off valves must be checked on at least an annual basis.

To check gas tightness of the safety shut-off valves, turn off the manual valve upstream of the appliance combination control. Remove 1/8 in. pipe plug on the inlet side of the combination control and connect a manometer to that tap. Turn the manual valve ON to apply pressure to the combination control. Note the pressure reading on the manometer, then turn the valve OFF. A loss of pressure indicates a leak. If a leak is detected, use soap solution to check all threaded connections. If no leaks is found, combination control is faulty and must be replaced before putting appliance back in service.

▲ WARNING It is the service technician's responsibility to check all safety controls! Check and test the operational functions of all safety devices supplied with this unit, and ensure that all are operating effectively. Failure to do so could result in unsafe conditions and may result in death, serious injury or property damage.

All Maintenance/Service info should be recorded accordingly on the Inspection Sheet provided on back cover of this manual. Should maintenance be required, perform the following inspection and service routine:

1. Inspect the area near the unit to be sure that there is no combustible material located within the minimum safety clearance requirements listed in this manual.

▲ WARNING Under no circumstances should combustible material be located within the clearances specified in this manual. Failure to provide proper clearance could result in personal injury or equipment damage from fire.

2. Turn off the manual gas valve and electrical power to the duct furnace.
3. Remove access panel.
4. To clean or replace the burners:
 - a. Disconnect the gas inlet pipe.
 - b. Remove the four (4) screws that hold the manifold in place, and remove the manifold, gas valve, and gas inlet pipe assembly.
 - c. Visually inspect the burners and heat exchanger tubes for signs of soot or debris.
 - d. If burners require cleaning, they can be cleaned with a wire brush and/or compressed air.
 - e. If inside surface of heat exchanger tubes require cleaning, remove manifold bracket sub-assembly by removing four (4) screws holding it in place.
5. With the burners removed, use a flexible wire brush and compressed air to clean the inside surfaces of the heat exchanger tubes.
6. Inspect air inlet for blockage/debris. Clear if any found.
7. Reassemble the duct furnace by replacing all parts in reverse order.
8. Complete the appropriate unit start-up procedure as given in the Operation section of this manual (see lighting instruction plate on the access side of the unit).
9. Check all gas control valves and pipe connections for leaks.
10. Check the operation of the automatic gas valve by lowering the setting of the thermostat, stopping the operation of the gas duct furnace. The gas valve should close tightly, completely extinguishing the flame on the burners.
11. Check lubrication instructions on power vent motor. If oiling is required, add 1 or 2 drops of electric motor oil as follows:
 - a. Light Duty – After 3 years or 25,000 hours of operation.
 - b. Average Duty – Annually after 3 years or 8,000 hours of operation.
 - c. Heavy Duty – Annually after 1 year or at least 1,500 hours of operation.

▲ CAUTION Never over oil the power vent motor or premature failure may occur!

12. Check and test the operational functions of all safety devices supplied with your unit.

IDENTIFICATION OF PARTS

TUBULAR DUCT FURNACE

Figure 13 – Tubular Duct Furnace, Exploded View

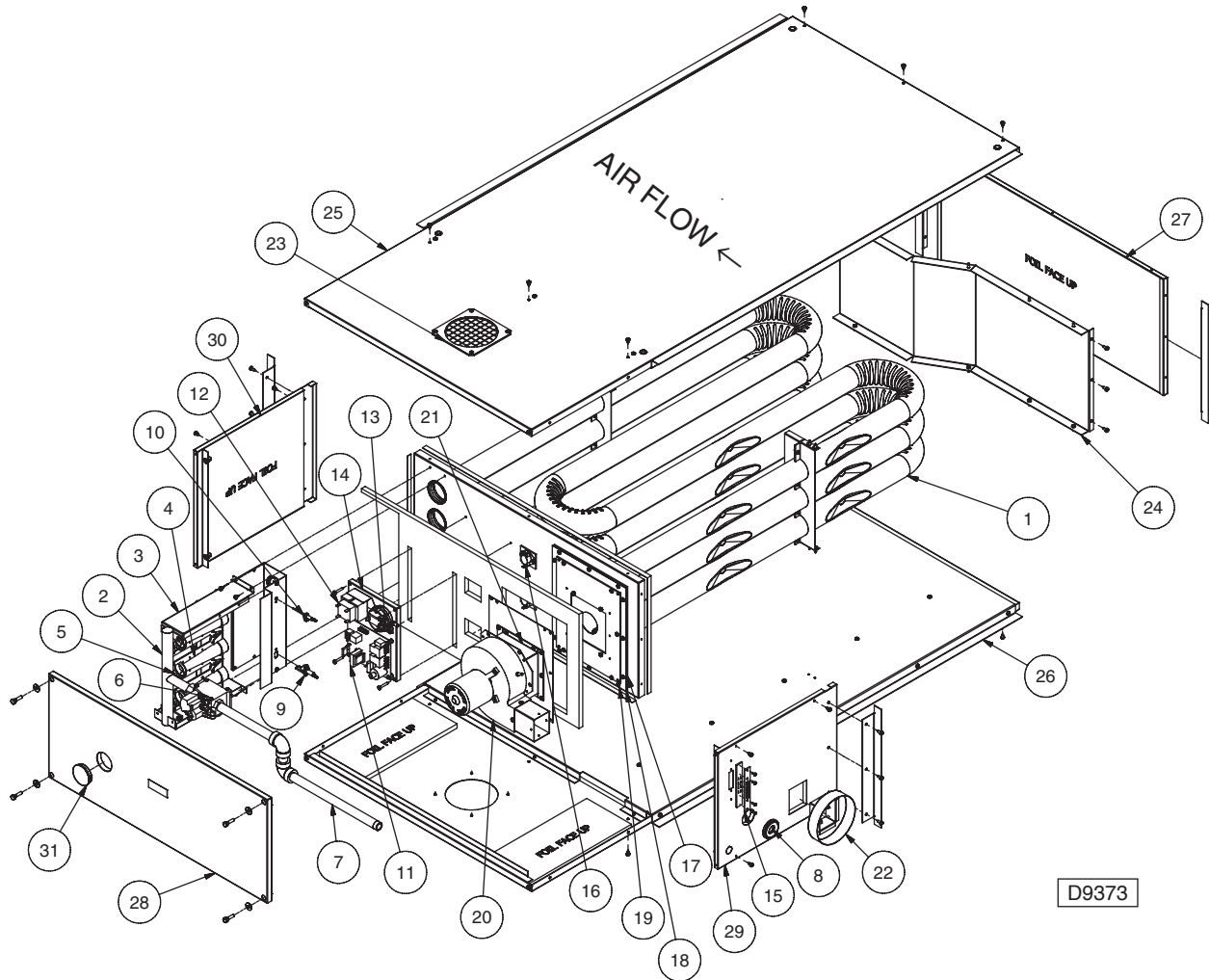

Tubular Duct Furnace Component Index:

- | | | | |
|---|--------------------------|------------------------------------|----------------------------|
| 1. Vestibule panel/tube assembly (heat exchanger) | 8. Gas inlet grommet | 18. Flue collector gasket | 25. Top panel |
| 2. Manifold | 9. Flame sensor | 19. Flue collector cover panel | 26. Bottom panel |
| 3. Manifold bracket/sub assembly | 10. Spark ignitor | 20. Power vent assembly | 27. Right side panel |
| 4. Inshot burner | 11. Control board | 21. Power vent extension/stand-off | 28. Left side/Access panel |
| 5. Burner orifice | 12. Transformer | 22. Flue collar | 29. Rear panel |
| 6. Gas valve | 13. Air pressure switch | 23. Air inlet screen | 30. Front panel |
| 7. Gas inlet pipe | 14. Control sub-panel | 24. Baffle | 31. Peep hole sight glass |
| | 15. Terminal block plate | | |
| | 16. High limit switch | | |
| | 17. Flue collector | | |

HOW TO ORDER REPLACEMENT PARTS

Please send the following information to your local representative. If further assistance is needed, contact the manufacturer's customer service department.

- Unit Number
- Serial Number
- Part Description and Number as shown above or in the Replacement Parts Catalog

Table 8A – Tubular Duct Furnace Troubleshooting Guide

SYMPTOMS	POSSIBLE CAUSE(S)	CORRECTIVE ACTION
A. Flame pops back.	1. Burner orifice too small.	1. Check with local gas supplier for proper orifice size and replace. Refer to “Gas Input Rate” section of this manual.
B. Noisy flame.	1. Irregular orifice causing whistle or resonance. 2. Excessive gas input.	1. Replace orifice. 2. Test and reset manifold pressure (see “Gas Supply Pressure” Table in the Pipe Installation section of this manual.)
C. Yellow tip flame. Note: Some yellow tipping on LP gas is permissible.	1. Clogged main burners. 2. Misaligned orifices. 3. Insufficient combustion air. 4. Unit possibly over fired. 5. Partially blocked flue vent pipe.	1. Clean main burner ports. 2. Replace manifold assembly. 3. Refer to “Installation - Clearances” and “Venting” sections in this manual to ensure unit is properly mounted and vented. 4. Check gas input and manifold pressures. 5. Check flue vent pipe and clear as needed.
D. Floating flame.	1. Blocked venting. 2. Insufficient combustion air. 3. Blocked heat exchanger. 4. Air leak into combustion chamber or flue collector.	1. Check flue vent pipe and clear as needed. 2. Check combustion air inlet openings and/or vent pipe and clear as needed. 3. Clean heat exchanger. Refer to “Maintenance” section of this manual. 4. Check flue collector and clear as needed.
E. Gas odor. Shut off gas supply immediately!	1. Gas leak. Shut off gas supply immediately! 2. Leaking gas test port on valve. 3. Blocked heat exchanger. 4. Blocked flue collector. 5. Negative pressure in the building.	1. Inspect all gas piping and repair accordingly. 2. Check to ensure gas test ports are sealed. 3. Clean heat exchanger. Refer to “Maintenance” section of this manual. 4. Check flue collector and clear as needed. 5. See “Installation” section of this manual.
F. Delayed ignition.	1. Improper ground. 2. Bad or broken spark cable. 3. Faulty control board. 4. Pressure regulator set too low. 5. Main burner orifices dirty. 6. Improper venting.	1. Check grounding wires and spark ignitor connections. 2. Inspect spark cable connections and cuts. Replace if necessary. 3. Check to ensure spark ignitor is energized after pre-purge period. 4. Test and reset manifold pressure (see “Gas Supply Pressure” Table in the Pipe Installation section of this manual.) 5. Clean or replace orifices. 6. Refer to “Venting” section of this manual.

Table 8A – Tubular Duct Furnace Troubleshooting Guide (continued)

SYMPTOMS	POSSIBLE CAUSE(S)	CORRECTIVE ACTION
G. Failure to ignite.	<ol style="list-style-type: none"> 1. Gas leak. Shut off gas supply immediately! 2. No power supply to the unit. 3. Thermostat not calling. 4. Defective high limit switch. 5. Defective air pressure switch. 6. Defective spark ignitor, gas valve, thermostat or transformer. 7. Loose wiring. 8. Improper ground. 9. Improper thermostat or transformer wiring. 	<ol style="list-style-type: none"> 1. Open all manual valves, check for leaks. Inspect all gas piping and repair accordingly. 2. Turn on power supply, check fuses and replace if bad. 3. Turn up thermostat. Check for 24V on terminals R and W1 on terminal strip. 4. Check switch for continuity if open with no heat present; replace. 5. Check switch operation to ensure switch closes after power vent purge period. If it does not make, check tubing connections for blockage. 6. Check for continuity and voltage in safety and control circuits; replace an item where continuity or voltage not found. 7. Check all wiring per diagram. 8. Check all ground wires and connections. 9. Check both for wiring according to diagram.
H. Condensation.	<ol style="list-style-type: none"> 1. Improper venting. 2. Unit under fired. 3. Building/space too cold. 	<ol style="list-style-type: none"> 1. Refer to “Venting” section of this manual. 2. Check gas supply pressures to the unit. Refer to “Gas Supply Pressure” Table in the Pipe Installation section of this manual. 3. A minimum of 50°F (10°C) thermostat setting must be maintained to deter formation of condensation. See “Installation” section of this manual.
I. Burners will not shut off.	<ol style="list-style-type: none"> 1. Thermostat located improperly. 2. Improper thermostat wiring. 3. Shorted circuit. 4. Defective thermostat. 5. Defective/sticking gas valve. 6. Defective control board. 7. Excessive gas supply pressure. 	<ol style="list-style-type: none"> 1. Relocate thermostat away from outside wall or drafts. 2. Check thermostat circuit for open and close on heater terminal strip “R” and “W.” 3. Check thermostat circuit for shorts or any staples piercing wires. 4. If thermostat is calling after set point has been satisfied, replace. 5. Check for 24V on gas valve terminals when thermostat not calling. Replace if necessary. 6. Check for 24V at terminals “R” and “W.” If not present and board is not in flash code mode, replace board. 7. Refer to “Gas Supply Pressure” Table in the Pipe Installation section of this manual.

Table 8A – Tubular Duct Furnace Troubleshooting Guide (continued)

SYMPTOMS	POSSIBLE CAUSE(S)	CORRECTIVE ACTION
J. Rapid burner cycling.	<ol style="list-style-type: none"> 1. Loose electrical connections at thermostat or gas valve. 2. Unit cycling on high limit. 3. Thermostat located improperly. 4. Defective high limit switch. 	<ol style="list-style-type: none"> 1. Tighten all electrical connections. 2. Check for proper air supply across heat exchanger and proper gas supply. 3. Relocate thermostat away from outside wall or drafts. 4. Jumper high limit switch wiring (orange and yellow wires). If burner operating normally, replace switch.
K. Not enough heat.	<ol style="list-style-type: none"> 1. Incorrect gas input. 2. Unit undersized. 3. Thermostat malfunction. 4. Unit cycling on high limit. 5. Incorrect orifice sizes. 6. Incorrect airflow. 	<ol style="list-style-type: none"> 1. Refer to “Gas Input Rate” in the Operation section of this manual. 2. Is the unit output sized correctly for the heat loss of the space? Has the space been enlarged? Is the unit located in the space properly (see “Installation” section of this manual)? 3. Check thermostat circuit; 24V on terminals “R” and “W” on terminal strip. 4. Check air movement across the heat exchanger. Check gas input to ensure unit is not over fired. Check heat exchanger to ensure unit is not dirty. 5. Check orifice size (refer to “Gas Input Rate” in the Operation section of this manual). 6. See blower manufacturer for corrective action(s).
L. Too much heat.	<ol style="list-style-type: none"> 1. Unit is over fired. 2. Thermostat malfunction. 3. Unit runs continuously. 4. Defective gas valve. 5. Excessive gas supply pressure. 6. Incorrect airflow. 	<ol style="list-style-type: none"> 1. Refer to “Gas Input Rate” in the Operation section of this manual. Check orifice size. Replace if too large. 2. Check thermostat for operation, to ensure circuit open and closes. 3. Check wiring per diagram. Check operation at the gas valve. Look for a short in thermostat circuit. 4. Replace valve and check pressure setting (see “Gas Supply Pressure” Table in the Pipe Installation section of this manual). 5. Refer to “Gas Supply Pressure” Table in the Pipe Installation section of this manual. 6. See blower manufacturer for corrective action(s).
M. Cold air is delivered during heater operation.	<ol style="list-style-type: none"> 1. Incorrect manifold pressure or gas input. 2. Incorrect airflow. 	<ol style="list-style-type: none"> 1. Test and reset manifold pressure (see “Gas Supply Pressure” Table in the Pipe Installation section of this manual.) 2. See blower manufacturer for corrective action(s).

Table 8A – Tubular Duct Furnace Troubleshooting Guide (continued)

SYMPTOMS	POSSIBLE CAUSE(S)	CORRECTIVE ACTION
N. High limit is tripping.	<ol style="list-style-type: none"> 1. Unit is over fired. 2. Incorrect airflow. 3. Defective high limit switch. 4. Defective control board. 	<ol style="list-style-type: none"> 1. Refer to “Gas Input Rate” in the Operation section of this manual. Check orifice size. Replace if too large. 2. See blower manufacturer for corrective action(s). 3. Check operation of switch. If switch is open during operation, check gas pressure and/or CFM; adjust accordingly. If switch is open during start-up, replace switch. 4. Check for 24V on line side of high limit. Constant voltage should be recorded. If not, control board is suspect. Check flash code.
O. Power ventor will not run.	<ol style="list-style-type: none"> 1. No power supply to the unit. 2. Thermostat not calling. 3. Loose wiring or connection. 4. Motor overload protection is tripping or bad motor. 5. Defective control board. 6. Motor not oiled. 	<ol style="list-style-type: none"> 1. Turn on power supply, check fuses and replace if bad. 2. Turn up thermostat. Check for 24V on terminals R and W1 on terminal strip. 3. Check all wiring in the power vent circuit to ensure good connection, including “neutral.” 4. Check for 115V between motor leads and check amp draw of motor. Replace if necessary. 5. Check for continuous 115V on terminal “CBM Blower” and neutral during call for heat. If not present and all checks are normal, replace. 6. Refer to “Maintenance” section of this manual.
P. Power ventor turns on and off during operation.	<ol style="list-style-type: none"> 1. Power ventor improperly wired. 2. Motor overload cycling or defective motor. 3. Defective control board. 4. Motor not oiled. 	<ol style="list-style-type: none"> 1. Check power ventor circuit per wiring diagram. 2. Check motor voltage and amp draw against motor name plate, replace if motor found defective. 3. Check for continuous 115V on terminal “CBM Blower” and neutral during call for heat. If not present and all checks are normal, replace. 4. Refer to “Maintenance” section of this manual.
Q. Power ventor will not stop.	<ol style="list-style-type: none"> 1. Power ventor improperly wired. 2. Main burner did not light on call for heat. 3. Defective control board. 	<ol style="list-style-type: none"> 1. Check power ventor circuit per wiring diagram. 2. Heater is in lockout mode; check flash code table for problem. 3. If no flash codes present along with no call for heat, replace control board.
R. Noisy power ventor.	<ol style="list-style-type: none"> 1. Power ventor wheel loose. 2. Power ventor wheel is dirty. 3. Power ventor wheel is rubbing on housing. 4. Bearings are dry. 	<ol style="list-style-type: none"> 1. Replace or tighten. 2. Clean power ventor wheel. 3. Realign power ventor wheel. 4. Oil bearing on power ventor motor (refer to label on motor).

Table 8B - Tubular Duct Furnace Troubleshooting with LED Indicator Assistance

No Cycling or appliance power or thermostat call for heat since appliance failure has occurred.

▲ WARNING

Line voltage power can cause product damage, severe injury or death. Only a trained experienced service technician should perform this trouble-shooting.

1. Check the system thermostat to make sure it is calling for heat. (Do not cycle the thermostat on and off at this time.)

2. Do not interrupt power to the control board by opening any electrically interlocked panels.
3. Observe the LED indicator on the front panel (a green LED indicates system faults); check and repair system as noted in the chart below.

***NOTICE: Air flow proving switch and power ventor hose barbs must be free of any dust or debris at all times. Periodically check these openings and/or if any problems occur.**

LED STATUS	INDICATES	CHECK/REPAIR
Slow Flash	Control OK, no call for heat.	Not Applicable
Fast Flash	Control OK, call for heat present.	Not Applicable
Steady Off	Internal control fault, or no power.	<ol style="list-style-type: none"> 1. Line voltage on terminals 120 and C on transformer. 2. Low voltage (24V) on terminals 24 and C on transformer. 3. 5 Amp fuse on circuit board.
Steady On	Control internal failure or bad ground.	<ol style="list-style-type: none"> 1. Common side of transformer grounded to chassis. 2. Loose spark ignitor.
2 Flashes	In lockout from failed ignitions or flame losses.	<ol style="list-style-type: none"> 1. Gas supply off or gas supply pressure too low. 2. Flame sense rod contaminated or loose wire. 3. Gas valve switch is off or wires are not connected. 4. Broken or cracked porcelain on flame probe or spark ignitor.
3 Flashes	Pressure Switch open with inducer on or closed with inducer off.	<ol style="list-style-type: none"> 1. Obstructions or restrictions in appliance air intake or flue outlet are preventing proper combustion airflow. 2. Moisture or debris in tubing that connects pressure switch and draft inducer. 3. Airflow switch jumpered or miswired.
4 Flashes	Limit or rollout switch is open.	<ol style="list-style-type: none"> 1. Open manual reset rollout switch. 2. Gas pressure too high, over fire condition. 3. Incorrect airflow due to blockage or motor not operating.
5 Flashes	Flame sensed while gas valve is off.	<ol style="list-style-type: none"> 1. Flame probe miswired or shortened.
6 Flashes	On-board microprocessors disagree.	<ol style="list-style-type: none"> 1. Thermostat is interfering with control board.

LIMITED WARRANTY

Tubular Duct Furnaces

1. The "Manufacturer" warrants to the original owner at original installation site that the above model Gas-Fired Heater ("the Product") will be free from defects in material or workmanship for (1) year from the date of shipment from the factory, or one and one-half (1-1/2) years from the date of manufacture, whichever occurs first. The Manufacturer further warrants that the complete heat exchanger, flue collector, and burners be free from defects in material or workmanship for a period of ten (10) years from the date of manufacture. If upon examination by the Manufacturer the Product is shown to have a defect in material or workmanship during the warranty period, the manufacturer will repair or replace, at its option, that part of the Product which is shown to be defective.
2. This limited warranty does not apply:
 - a. if the product has been subjected to misuse or neglect, has been accidentally or intentionally damaged, has not been installed, maintained, or operated in accordance with furnished written instructions, or has been altered or modified in any way by any unauthorized person.
 - b. to any expenses, including labor or material, incurred during removal or reinstallation of the Product
 - c. to any damage due to corrosion by chemicals, including halogenated hydrocarbons, precipitated in the air
 - d. to any workmanship of the installer of the Product
3. This limited warranty is conditional upon:
 - a. advising the installing contractor, who in turn notify the distributor or manufacturer
 - b. shipment to the Manufacturer of that part of the Product thought to be defective. Goods can only be returned with prior written approval of the Manufacturer. All returns must be freight prepaid.
 - c. determination in the reasonable opinion of the Manufacturer that there exists a defect in material or workmanship
4. Repair or replacement of any part under this Limited Warranty shall not extend the duration of the warranty with respect to such repaired or replaced part beyond the stated warranty period.
5. **THIS LIMITED WARRANTY IS IN LIEU OF ALL WARRANTIES, EITHER EXPRESS OR IMPLIED, AND ALL SUCH OTHER WARRANTIES, INCLUDING WITHOUT LIMITATION IMPLIED WARRANTIES OF MERCHANTABILITY OR FITNESS FOR A PARTICULAR PURPOSE, ARE HEREBY DISCLAIMED AND EXCLUDED FROM THIS LIMITED WARRANTY. IN NO EVENT SHALL THE MANUFACTURER BE LIABLE IN ANY WAY FOR ANY CONSEQUENTIAL, SPECIAL, OR INCIDENTAL DAMAGES OF ANY NATURE WHATSOEVER, OR FOR ANY AMOUNTS IN EXCESS OF THE SELLING PRICE OF THE PRODUCT OR ANY PARTS THEREOF FOUND TO BE DEFECTIVE. THIS LIMITED WARRANTY GIVES THE ORIGINAL OWNER OF THE PRODUCT SPECIFIC LEGAL RIGHTS. YOU MAY ALSO HAVE OTHER RIGHTS WHICH MAY VARY BY JURISDICTION.**

In the interest of product improvement, we reserve the right to make changes without notice.

TUBULAR DUCT FURNACE UNIT NUMBER DESCRIPTION

Digit	T	X	X	X	-	1	2	3	4	5	6	7	8	9	10	11	12	13	14	15	+
Item	Prefix					UT	CA			FT	FM	GT	AL	GC	SV	MT	MS	DL	AS		

(Internal use Only)

1, 2 - Unit Type [UT]

TD/BTD - Tubular Duct Furnace

3, 4, 5 - Capacity [CA]

100 - 100,000 BTU/HR
 150 - 150,000 BTU/HR
 200 - 200,000 BTU/HR
 250 - 250,000 BTU/HR
 300 - 300,000 BTU/HR
 350 - 350,000 BTU/HR
 400 - 400,000 BTU/HR

6 - Furnace Type [FT]

A - Left Side Access

Note: Field convertible to right side access; refer to unit installation instructions.

7 - Heat Exchanger (Furnace) Material [FM]

1 - Aluminized Steel (Standard)
 2 - 409 Stainless Steel

Note: Heat Exchanger Material [FM] selection includes flue collector material.

8 - Gas Type [GT]

N - Natural Gas

P - Propane Gas (LP)

9 - Altitude [AL]

S - 0-4,999 feet

T - 5,000-11,999 feet

Note: Installations over 2,000 ft. require gas input deration in the field.

Refer to unit installation instructions.

10 - Direct Spark Gas Control [GC]

1 - Single Stage
 2 - Two Stage
 3 - Electronic Modulation w/Room Sensing
 4 - Electronic Modulation w/Duct Sensing
 5 - Electronic Modulation w/Duct Sensing & Room Override Stat
 6 - Electronic Modulation w/External 4-20 mA Input
 7 - Electronic Modulation w/External 0-10 VDC Input

11 - Supply Voltage [SV]

1 - 115/1/60 5 - 230/3/60
 2 - 208/1/60 6 - 460/3/60
 3 - 230/1/60 7 - 575/3/60
 4 - 208/3/60 Z - Special

Note: Supply Voltages [SV] 2-7 include field mounted step down transformer.

12 - Motor Type [MT]

0 - None/Not Applicable

13 - Motor Sizes [MS]

0 - None/Not Applicable

14 - Design Level [DL]

A - First Design Level

15+ - Accessories [AS]

FACTORY INSTALLED

K5 - Air Flow Prove Switch

P4 - Terminal Block Wiring

P6 - Summer/Winter Switch

S5 - Stainless Steel Burners

† FIELD INSTALLED (AS-____)

† All Field Installed Accessories are to be entered as a separate line item using the catalog number which utilizes "11AS" as a prefix. i.e: G3 becomes 11AS-G3.

A7 - High Pressure Regulator:

A7-1/2-1 - Regulator for 0.5-10 PSI

A7-3/8-1 - Regulator for 10-20 PSI

A7-5/16-1 - Regulator for 20-35 PSI

F1 - One-Stage T675A Ductstat

F2 - Two-Stage T678A Ductstat

G1 - One-Stage Mercury Free Thermostat (Round)

G2 - One-Stage Mercury Free Thermostat w/Guard Kit

G3 - One-Stage Mercury Free Thermostat w/Fan Switch

G5 - Two-Stage Mercury Free Thermostat w/Fan Switch

G6 - Locking Thermostat Cover

G9 - One-Stage Mercury Free Heating Only Thermostat

GW - WiFi Thermostat TH8321WF1001/U

H5 - Low Ambient Control

M2-2 - Vent Cap (5 inch) (Unit Capacity 100-200)

M2-3 - Vent Cap (6 inch) (Unit Capacity 250-400)

P5 - 24V SPST Relay-Specify Purpose

S4 - Stainless Steel Drip Pan

X5 - Horizontal and Vertical Louver Kit

X8-H5 - Horizontal Combustion Air Inlet Kit, 5 inch (Unit Capacity 100-200)

X8-H6 - Horizontal Combustion Air Inlet Kit, 6 inch (Unit Capacity 250-400)

X8-V5 - Vertical Combustion Air Inlet Kit, 5 inch (Unit Capacity 100-200)

X8-V6 - Vertical Combustion Air Inlet Kit, 6 inch (Unit Capacity 250-400)

X9-DBL-5 - Air Inlet Kit, 5 inch (Unit Capacity 100-200)

X9-DBL-6 - Air Inlet Kit, 6 inch (Unit Capacity 250-400)

Note: X9 kits allow for conversion to separated combustion and include the M2 vent cap for the combustion air inlet pipe. X8 kits allow for conversion to separated combustion and venting concentrically through one roof or wall penetration.

GAS EQUIPMENT START-UP

Customer _____ Job Name & Number _____

PRE-INSPECTION INFORMATION With power and gas off.

Type of Equip: Duct Furnace

Serial Number _____ Model Number _____

Name Plate Voltage: _____ Name Plate Amperage: _____

Type of Gas: Natural LP Tank Capacity _____ lbs. Rating: _____ BTU @ _____ °F
_____ kg _____ kw @ _____ °C

- Are all panels, doors, vent caps in place?
- Has the unit suffered any external damage? Damage _____
- Does the gas piping and electric wiring appear to be installed in a professional manner?
- Has the gas and electric been inspected by the local authority having jurisdiction?
- Is the gas supply properly sized for the equipment?
- Were the installation instructions followed when the equipment was installed?
- Have all field installed controls been installed?
- Do you understand all the controls on this equipment? **If not, contact your wholesaler or rep.**
(DO NOT START this equipment unless you fully understand the controls.)

GENERAL

With power and gas off.

- Make certain all packing has been removed.
- Tighten all electrical terminals and connections.
- Check all controls for proper settings.

GAS HEATING

With power and gas on.

- Inlet gas pressure. _____ inch WC or _____ kPa
- Burner ignition.
- Manifold gas pressure. _____ inch WC or _____ kPa
- Check electronic modulation. Set at: _____
- Cycle and check all other controls not listed.
- Check operation of remote panel.
- Entering air temp. _____ °F or _____ °C
- Discharge air temp. (high fire) _____ °F or _____ °C
- External static pressure _____ inch WC.
- Cycle by thermostat or operating control.
- Combustion reading
Carbon Monoxide _____ PPM
Carbon Dioxide _____ %

Remarks: _____
