

INSTALLATION INSTRUCTIONS AND PARTS IDENTIFICATION XH/BXH HIGH EFFICIENCY GAS-FIRED PROPELLER UNIT HEATERS

ATTENTION: READ THIS MANUAL AND ALL LABELS ATTACHED TO THE UNIT CAREFULLY BEFORE ATTEMPTING TO INSTALL, OPERATE OR SERVICE THESE UNITS! CHECK UNIT DATA PLATE FOR TYPE OF GAS AND ELECTRICAL SPECIFICATIONS AND MAKE CERTAIN THAT THESE AGREE WITH THOSE AT THE POINT OF INSTALLATION. RECORD THE UNIT MODEL AND SERIAL No. (s) IN THE SPACE PROVIDED. RETAIN FOR FUTURE REFERENCE.

Unit No. _____ Serial No. _____

FOR YOUR SAFETY
The use and storage of gasoline or other flammable vapors and liquids in open containers in the vicinity of this appliance is hazardous.



FOR YOUR SAFETY
If you smell gas:
1. Open windows.
2. Don't touch electrical switches.
3. Extinguish any open flame.
4. Immediately contact your gas supplier.



▲ WARNING Improper installation, adjustment, alteration, service, or maintenance can cause property damage, injury, or death. Read the installation, operating, and maintenance instruction thoroughly before installing or servicing this equipment.

APPROVED FOR USE IN CALIFORNIA

▲ WARNING Install, operate, and maintain unit in accordance with the manufacturer's instructions to avoid exposure to fuel substances, or substances from incomplete combustion, which can cause death or serious illness. The state of California has determined that these substances may cause cancer, birth defects, or other reproductive harm.

INSTALLER'S RESPONSIBILITY

Installer Please Note: This equipment has been test fired and inspected. It has been shipped free from defects from our factory. However, shipment and installation problems such as loose wires, leaks, or loose fasteners may occur. It is the installer's responsibility to inspect and correct any problem that may be found.

RECEIVING INSTRUCTIONS

Inspect shipment immediately when received to determine if any damage has occurred to the unit during shipment. After the unit has been uncrated, check for any visible damage to the unit. If any damage is found, the consignee should sign the bill of lading indicating such damage and immediately file claim for damage with the transportation company.

 **MESTEK, INC.**
260 NORTH ELM ST., WESTFIELD, MA 01085
TEL: (413) 564-5540
www.mestek.com



TABLE OF CONTENTS

DESCRIPTION	2	STANDARD COMBUSTION –	
GENERAL SAFETY INFORMATION.....	3	VERTICALLY VENTED (CAT. IV)	23
Installation Codes	3	SEPARATED COMBUSTION –	
Special Precautions.....	3	TWO PIPE VENTING	24-25
SPECIFICATIONS	4	SEPARATED COMBUSTION –	
Performance & Dimensional Data	4-5	CONCENTRIC VENTING.....	26-28
INSTALLATION	6	OPERATION	29
Locating Units.....	6	Explanation of Controls	29
Air for Combustion	6	Start-Up	29
Clearances	8	Shut Down	30
Suspension of Units.....	9-10	GAS INPUT RATE	31
INSTALLATION - GAS PIPING	11-12	HIGH ALTITUDE DERATION	32
Pipe Sizing.....	11	INDUCER SPEED BOARD CONFIGURATION	32
Pipe Installation	12	UNIT TROUBLESHOOTING GUIDE.....	33-34
INSTALLATION - CONDENSATE PIPING	13	LED TROUBLESHOOTING GUIDE	35
ELECTRICAL CONNECTIONS.....	14-19	Main Ignition Board Flash Codes	35
Thermostat Wiring and Location.....	14	Inducer Speed Board Flash Codes	35
Unit Wiring Diagrams.....	15-19	MAINTENANCE	36
VENTING - GENERAL GUIDELINES	20-21	WARRANTY	37-38
Flue Pipe Coupling and Reducer.....	20	IDENTIFICATION OF PARTS.....	39-40
Vent Termination Clearances.....	21	UNIT NUMBER DESCRIPTION	41
STANDARD COMBUSTION – HORIZONTALLY		START-UP AND INSPECTION SHEET	42
VENTED (CAT. IV).....	22		

NOTICE: It is the equipment owner’s responsibility to provide any scaffolding or other apparatus required to perform emergency service or annual/periodic maintenance to this equipment.

DESCRIPTION

The High Efficiency Gas-Fired Propeller Unit Heaters are factory assembled, power vented, low static pressure type propeller fan unit heaters designed to be suspended within the space to be heated. THESE HEATERS ARE NOT TO BE CONNECTED TO DUCTWORK. The designs are certified by ETL as providing a minimum of 93% thermal efficiency and are approved for use in California. Do not alter these units in any way. If you have any questions after reading this manual, contact the manufacturer.

The following terms are used throughout this manual, in addition to the ETL requirements to bring attention to the presence of potential hazards, or to important information concerning the product:

▲ DANGER Indicates an imminently hazardous situation which, if not avoided, will result in death, serious injury, or substantial property damage.

▲ WARNING Indicates an imminently hazard-ous situation which, if not avoided, could result in death, serious injury, or substantial property damage.

▲ CAUTION Indicates an imminently hazardous situation which, if not avoided, may result in minor injury or property damage.

NOTICE: Used to notify of special instructions on installation, operation, or maintenance which are important to equipment but not related to personal injury.

Figure 1 - High Efficiency Gas-Fired Propeller Unit Heater



GENERAL SAFETY INFORMATION

▲ WARNING Failure to comply with the general safety information may result in extensive property damage, severe personal injury, or death.

▲ WARNING This product must be installed by a licensed plumber or gas fitter when installed within the Commonwealth of Massachusetts.

Installation must be made in accordance with local codes, or in absence of local codes, with the latest edition of the ANSI Standard Z223.1 (N.F.P.A. No. 54) National Fuel Gas Code. All of the ANSI and NFPA Standards referred to in these installation instructions are those that were applicable at the time the design of this appliance was certified. The ANSI Standards are available from CSA Information Services, 1-800-463-6727. The NFPA Standards are available from the National Fire Protection Association, Batterymarch Park, Quincy, MA 02269. These unit heaters are designed for use in airplane hangars when installed in accordance with ANSI/NFPA No. 409, and in public garages when installed in accordance with NFPA No. 88A and NFPA No. 30A.

If installed in Canada, the installation must conform with local building codes, or in the absence of local building codes, with CSA-B149.1 "Installation Codes for Natural Gas Burning Appliances and Equipment" or CSA-B149.2 "Installation Codes for Propane Gas Burning Appliances and Equipment." These unit heaters have been designed and certified to comply with CSA 2.6. Also see sections on installation in AIRCRAFT HANGARS and PUBLIC GARAGES.

▲ WARNING Do not alter the unit heater in any way or damage to the unit and/or severe personal injury or death may occur!

▲ WARNING Disconnect all power and gas supplies before installing or servicing the heater. If the power disconnect is out of sight, lock it in the open position and tag it to prevent unexpected application of power. Failure to do so could result in fatal electric shock, or severe personal injury.

▲ CAUTION Ensure that all power sources conform to the requirements of the unit heater, or damage to the unit will result!

Follow installation instructions CAREFULLY to avoid creating unsafe conditions. All wiring should be done and checked by a qualified electrician, using copper wire only. All gas connections should be made and leak-tested by a suitably qualified individual, per instructions in this manual. Also follow procedures listed on GAS EQUIPMENT START-UP AND INSPECTION SHEET located in this manual.

Use only the fuel for which the heater is designed (see rating plate). Using LP gas in a heater that requires natural gas, or vice versa, will create risk of gas leaks, carbon monoxide poisoning, and explosion.

▲ WARNING Do not attempt to convert the heater for use with a fuel other than the one intended unless using a factory provided conversion kit. Such conversion is dangerous, as it will create the risks previously listed.

Make certain that the power source conforms to the electrical requirements of the heater.

▲ WARNING Do not depend upon a thermostat or other switch as sole means of disconnecting power when installing or servicing heater. Always disconnect power at main circuit breaker as described above. Failure to do so could result in fatal electric shock.

Special attention must be given to any grounding information pertaining to this heater. To prevent the risk of electrocution, the heater must be securely and adequately grounded. This should be accomplished by connecting a ground conductor between the service panel and the heater. To ensure a proper ground, the grounding means must be tested by a qualified electrician.

Do not insert fingers or foreign objects into heater or its air moving device. Do not block or tamper with the heater in any manner while in operation, or just after it has been turned off, as some parts may be hot enough to cause injury.

This heater is intended for general heating applications ONLY. It must NOT be used in potentially dangerous locations such as flammable, explosive, chemical-laden, or wet atmospheres.

Do not attach ductwork to this product or use it as a makeup air heater. Such usage voids the warranty and will create unsafe operation.

In cases in which property damage may result from malfunction of the heater, a back-up system or temperature sensitive alarm should be used.

▲ CAUTION The open end of piping systems being purged shall not discharge into areas where there are sources of ignition or into confined spaces UNLESS precautions are taken as follows: (1) by ventilation of the space, (2) control of the purging rate, (3) elimination of all hazardous conditions. All precautions must be taken to perform this operation in a safe manner!

The appliance is not to be used by persons (including children) with reduced physical, sensory or mental capabilities, or lack of experience and knowledge, unless they have been given supervision or instruction. Children being supervised should not play with the appliance.

Unless otherwise specified, the following conversions may be used for calculating SI unit measurements:

1 foot = 0.305 m	1000 BTU/cu. ft. = 37.5 MJ/m ³
1 inch = 25.4 mm	1000 BTU per hour = 0.293 kW
1 gallon = 3.785 L	1 inch water column = 0.249 kPa
1 pound = 0.453 kg	1 litre/second = CFM x 0.472
1 psig = 6.894 kPa	1 meter/second = FPM ÷ 196.8
1 cubic foot = 0.028m ³	

SPECIFICATIONS

Figure 2 - Dimensional Drawing, High Efficiency Gas-Fired Propeller Unit Heater

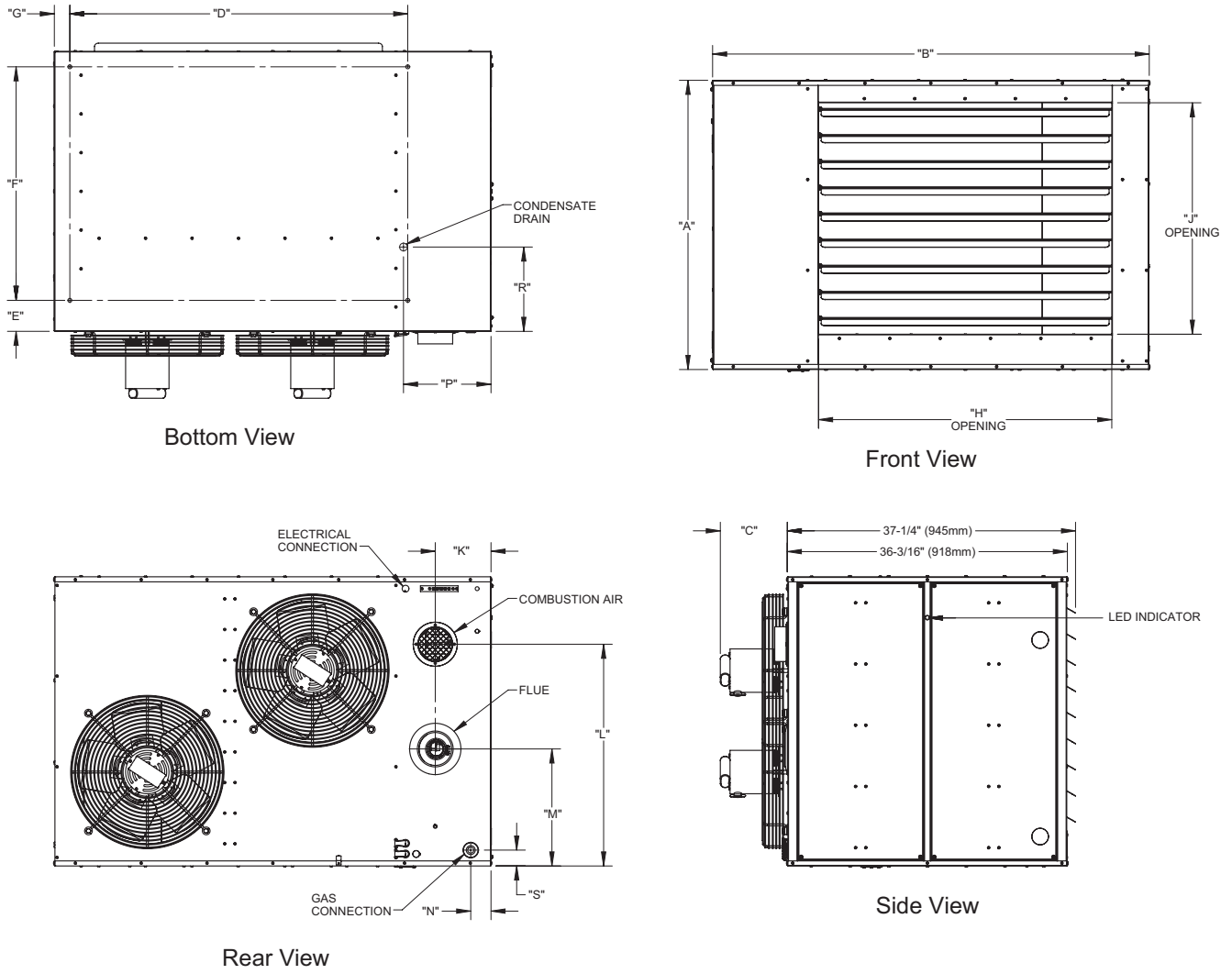

Table 1 - Performance and Dimensional Data - High Efficiency Unit Heater

Unit Size		50	100	150	200	250	300	350	400
PERFORMANCE DATA†									
Input Maximum -	BTU/Hr. (kW)	50,000 (14.6)	100,000 (29.3)	150,000 (43.9)	200,000 (58.6)	250,000 (73.2)	300,000 (87.9)	350,000 (102.5)	400,000 (117.2)
Input Minimum -	BTU/Hr. (kW)	20,000 (5.9)	40,000 (11.7)	60,000 (17.6)	80,000 (23.4)	100,000 (29.3)	120,000 (35.2)	140,000 (41.0)	160,000 (46.9)
Output -	BTU/Hr. (kW)	47,900 (14.0)	96,000 (28.1)	145,350 (42.6)	191,200 (56.0)	242,500 (71.1)	282,600 (82.8)	327,600 (96.0)	372,000 (109.0)
Thermal Efficiency	(%)	95.8	96.0	96.9	95.6	97.0	94.2	93.6	93.0
Free Air Delivery -	CFM (cu. m/s)	691 0.326	1830 0.863	2869 1.354	3567 1.683	4154 1.960	4675 2.206	6087 2.872	6124 2.890
Air Temperature Rise -	Deg. F (Deg C.)	64 (35.6)	50 (27.8)	47 (26.1)	50 (27.8)	53 (29.4)	56 (31.1)	51 (28.3)	58 (32.2)
Condensate Production	gph	0.38	0.67	1.06	1.38	1.65	1.70	2.06	2.58
Full Load Amps at 120V		6.7	7.4	14.0	14.0	23.0	24.6	24.6	24.6
Minimum Circuit Amps at 120V		7.3	8.9	15.4	15.5	25.6	27.2	27.2	27.2
Max. Overcurrent Protection at 120V		9.8	14.6	21.2	21.2	35.9	37.5	37.5	37.5
MOTOR DATA:									
	Motor HP (Qty)	1/14 (2)	1/2 (1)	1/2 (2)	1/2 (2)	1 (2)	1 (2)	1 (2)	1 (2)
	Motor kW	0.05	0.37	0.37	0.37	0.74	0.74	0.74	0.74
	Motor Type, ODP	SP	PSC	PSC	PSC	PSC	PSC	PSC	PSC
	RPM	1500	1500	1500	1500	1625	1625	1625	1625
	Amps @ 115V	5.2	6	12	12	21.4	21.4	21.4	21.4
DIMENSIONAL DATA - inches (mm)									
"A" Height to Top of Combustion Air Inlet		15-1/16 (383)	20-3/8 (518)	20-3/8 (518)	20-3/8 (518)	27-9/16 (700)	27-9/16 (700)	37-5/16 (948)	37-5/16 (948)
"B" Jacket Width of Unit		46-7/16 (1180)	46-7/16 (1180)	56-3/8 (1432)	56-3/8 (1432)	56-3/8 (1432)	56-3/8 (1432)	56-3/8 (1432)	56-3/8 (1432)
"C" Depth to Rear of Housing		4-1/2 (115)	7-7/8 (201)	7-7/8 (201)	7-7/8 (201)	8-5/8 (220)	8-5/8 (220)	8-5/8 (220)	8-5/8 (220)
"D" Hanging Distance Width		41-1/4 (1048)	41-1/4 (1048)	51-1/4 (1302)	51-1/4 (1302)	43-5/8 (1108)	43-5/8 (1108)	43-5/8 (1108)	43-5/8 (1108)
"E" Hanging Distance from Rear of Housing		4-3/16 (107)	4-3/16 (107)	4-3/16 (107)	4-3/16 (107)	4 (102)	4 (102)	4 (102)	4 (102)
"F" Hanging Distance Depth		27-3/4 (705)	27-3/4 (705)	27-3/4 (705)	27-3/4 (705)	30-3/16 (766)	30-3/16 (766)	30-3/16 (766)	30-3/16 (766)
"G" Hanging Distance from Fixed Side Panel		2-11/16 (68)	2-11/16 (68)	2-1/16 (53)	2-1/16 (53)	2-3/16 (56)	2-3/16 (56)	2-3/16 (56)	2-3/16 (56)
"H" Discharge Opening Width		27-7/8 (708)	27-7/8 (708)	37-7/8 (962)	37-7/8 (962)	37-7/8 (962)	37-7/8 (962)	37-7/8 (962)	37-7/8 (962)
"J" Discharge Opening Height		7-5/16 (186)	10-15/16 (278)	13-3/4 (349)	17-1/16 (434)	20-1/4 (515)	23-9/16 (598)	26-15/16 (684)	29-7/8 (759)
"K" Side Panel to Centerline Combustion Air and Flue		8-1/8 (206)	8-1/8 (206)	8-1/8 (206)	8-1/8 (206)	7-1/8 (181)	7-1/8 (181)	7-1/8 (181)	7-1/8 (181)
"L" Bottom Panel to Centerline Combustion Air		10 (254)	15 (381)	15 (381)	15 (381)	18-7/8 (479)	18-7/8 (479)	28-5/8 (727)	28-5/8 (727)
"M" Bottom Panel to Centerline Flue		3-15/16 (100)	5-1/2 (140)	5-1/2 (140)	5-1/2 (140)	10-1/4 (260)	10-1/4 (260)	15-1/8 (384)	15-1/8 (384)
"N" Side Panel to Centerline Gas Connection		2-7/16 (62)	2-7/16 (62)	2-5/16 (59)	2-5/16 (59)	2-5/16 (59)	2-5/16 (59)	2-5/16 (59)	2-5/16 (59)
"P" Side to Centerline Condensate Drain Connection		10-15/16 (278)	10-15/16 (278)	10-13/16 (275)	10-13/16 (275)	10-13/16 (275)	10-13/16 (275)	10-13/16 (275)	10-13/16 (275)
"R" Rear to Centerline Condensate Drain Connection		11-3/8 (289)	11-3/8 (289)	11-3/8 (289)	10-7/8 (276)	10-7/8 (276)	10-7/8 (276)	10-7/8 (276)	10-7/8 (276)
"S" Bottom to Centerline Gas Connection		2-11/16 (68)	2-3/16 (56)	1-3/16 (30)	3-3/16 (81)	2-3/16 (56)	1-5/8 (42)	1-5/8 (42)	1-15/16 (49)
Combustion Air Inlet Pipe Dia. -	in. (mm)	2" (51)	2" (51)	3" (76)	4" (102)	4" (102)	4" (102)	4" (102)	4" (102)
* Flue Pipe Dia -	in. (mm)	2" (51)	2" (51)	3" (76)	4" (102)	4" (102)	4" (102)	4" (102)	4" (102)
Gas inlet -	in.	1/2"	1/2"	1/2"	1/2"	3/4"	3/4"	3/4"	3/4"
Condensate Connection Dia.	in.	3/4"	3/4"	3/4"	3/4"	3/4"	3/4"	3/4"	3/4"
Approximate Unit Weight -	lb (kg)	195 (88.5)	245 (111.1)	310 (140.6)	325 (147.4)	420 (190.5)	425 (192.8)	510 (231.3)	515 (233.6)
Approximate Ship Weight -	lb (kg)	250 (113.4)	305 (138.3)	360 (163.3)	390 (176.9)	465 (210.9)	475 (210.9)	560 (254.0)	565 (256.3)

† Ratings shown are for unit installations at elevations between 0 and 2,000 feet (0 to 610m). For unit installations in U.S.A. above 2,000 feet (610m), the unit input must be field derated 4% for each 1,000 feet (305m) above sea level; refer to local codes, or in absence of local codes, refer to the latest edition of the National Fuel Gas Code, ANSI Standard Z223.1 (NFPA No. 54).

For installations in Canada, any reference to deration at altitudes in excess of 2,000 feet (610m) are to be ignored. At altitudes of 2,000 feet to 4,500 feet (610 to 1372m), the unit must be field derated and be so marked in accordance with the ETL certification. See HIGH ALTITUDE DERATION section and Table 11A for deration information.

* Field installed PVC fittings provided with unit sizes 150-400 as follows:

- Size 150 units come with a 2" to 3" PVC reducer
- Size 200/300 units come with a 2" to 4" PVC reducer
- Size 350/400 units come with a 2" to 4" PVC drain tee fitting

Reducers/drain tee fittings are to be field installed per Venting instructions.

LEGEND: ODP = Open Drip Proof, PSC = Permanent Split Capacitor, SP = Shaded Pole

INSTALLATION

▲ WARNING Do not install unit heaters in corrosive or flammable atmospheres! Premature failure of, or severe damage to the unit will result!

▲ WARNING Avoid locations where extreme drafts can affect burner operation. Unit heaters must not be installed in locations where air for combustion would contain chlorinated, halogenated or acidic vapors. If located in such an environment, premature failure of the unit will occur!

Since the unit is equipped with an automatic gas ignition system, the unit heater must be installed such that the gas ignition control system is not directly exposed to water spray, rain or dripping water. Do not install or operate the unit indoors.

Maximum altitude for this unit is 14,000 feet (4,267 meters) unless otherwise noted. For altitudes higher than 14,000 feet (4,267 meters), contact your customer service representative.

NOTICE: Location of unit heaters is related directly to the selection of sizes. Basic rules are as follows:

RESIDENTIAL INSTALLATIONS (Sizes 50 - 150 only): This unit heater is design certified under ANSI Z83.8 for residential use as a utility heater. A utility heater is defined as: a low static unit heater for heating of non-living spaces that are attached to, adjacent to, or part of a structure that contains space for family living quarters.

AIRCRAFT HANGARS: Unit Heaters must be installed in aircraft hangars as follows: In aircraft hangars, unit heaters must be at least 10 feet (3.0 m) above the upper surface of wings or engine enclosures of the highest aircraft to be stored in the hangar, and 8 feet (2.4 m) above the floor in shops, offices and other sections of the hangar where aircraft are not stored or housed. Refer to current ANSI/NFPA No. 409, Aircraft Hangars. In Canada, installation is suitable in aircraft hangars when acceptable to the enforcing authorities.

PUBLIC GARAGES: In repair garages, unit heaters must be located at least 8 feet (2.4 m) above the floor. Units must be installed by code with separated combustion venting, standard combustion is not allowed. Refer to the latest edition of NFPA 30A, Repair Garages.

PARKING STRUCTURES: In parking structures, unit heaters must be installed so that the burner flames are located a minimum of 18 inches (457 mm) above the floor or protected by a partition not less than 18 inches (457 mm) high. Refer to the latest edition of NFPA 88A, Parking structures.

In Canada, installation must be in accordance with the latest edition of CSA B149 "Installation Codes for Gas Burning Appliances and Equipment."

AIR DISTRIBUTION: Direct air towards areas of maximum heat loss. When multiple heaters are involved, circulation of air around the perimeter is recommended where heated air flows along exposed walls. Satisfactory results can also be obtained where multiple heaters are located toward the center of the area with heated air directed toward the outside walls. Be careful to avoid all obstacles and obstructions which could impede the warm air distribution patterns.

NOTICE: Unit heaters should not be installed to maintain low temperatures and/or freeze protection of buildings. A minimum of 45°F (7.2°C) thermostat setting must be maintained. If the ambient temperature drops to below freezing, it may result in damage to heat exchanger and/or components.

AIR FOR COMBUSTION: The unit heater shall be installed in a location in which the facilities for ventilation permit satisfactory combustion of gas, proper venting, and the maintenance of ambient air at safe limits under normal conditions of use. The unit heater shall be located in such a manner as not to interfere with proper circulation of air within the confined space. When buildings are so tight that normal infiltration does not meet air requirements, outside air shall be introduced per Sections 1.3.4.2 and 1.3.4.3 of ANSI Z223.1 for combustion requirements. A permanent opening or openings having a total free area of not less than one square inch per 5,000 BTU/Hr. (1.5 kW) of total input rating of all appliances within the space shall be provided.

NOTICE: Unit Heater sizing should be based on heat loss calculations where the unit heater output equals or exceeds heat loss.

NOTICE: Unit should be installed in an area where the entering air does not exceed 104°F. Temperatures above 104°F will cause the propeller motor to trip on its thermal overload protection, requiring a cool down period before the motor can reset.

Table 2 - Heat Throw Data

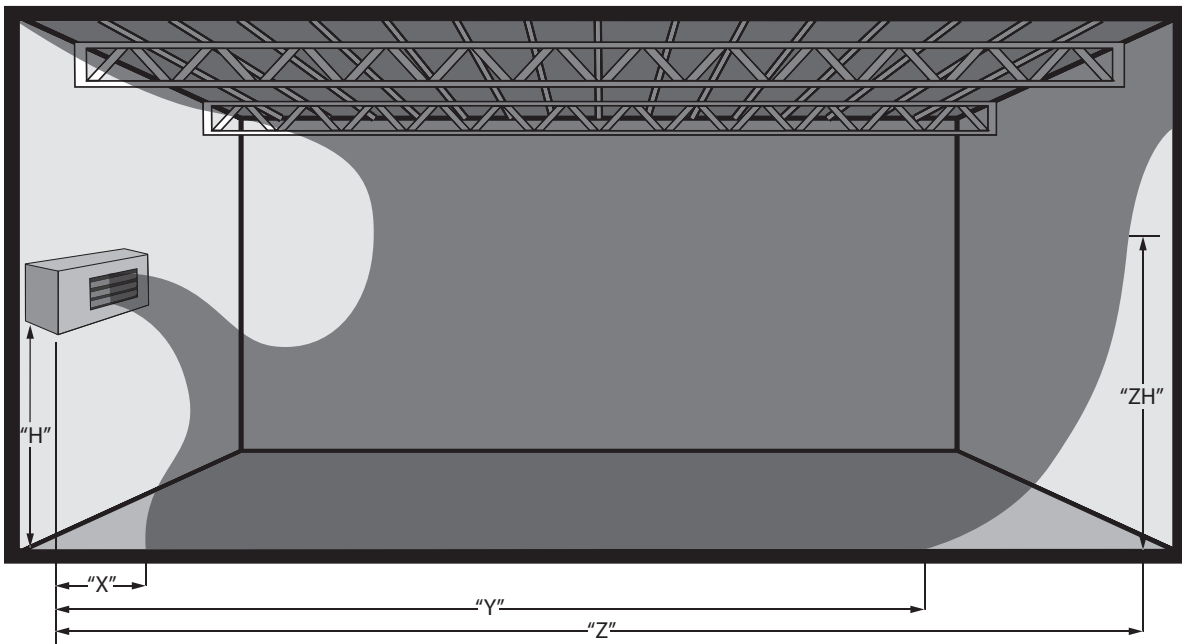

Notes:

1. All throw data figures are approximations. Allowances should be made for optimum performance, altitude, etc.
2. "NR" - Units are not recommended at these mounting heights.
3. Heat throw figures were determined with all unit louvers set to a 45 degree angle.
4. Throw data figures are listed in feet (meters).
5. Due to hot air naturally rising; in buildings with high ceilings the throw distance will be significantly further than the above values but much of the heat will be in the unoccupied space up at the ceiling. The below throw distances are based on the heat that will be in the occupied space. These values have been independently verified by a 3rd party company.

Size 50					Size 100				
H	X	Y	Z	ZH	H	X	Y	Z	ZH
8 (2.44)	4 (1.22)	12 (3.66)	18 (5.49)	12 (3.66)	8 (2.44)	5 (1.52)	44 (13.41)	51 (15.54)	12 (3.66)
10 (3.06)	4 (1.22)	12 (3.66)	17 (5.18)	12 (3.66)	10 (3.05)	5 (1.52)	46 (14.02)	51 (15.54)	12 (3.66)
12 (3.66)	NR	NR	NR	NR	12 (3.66)	7 (2.13)	44 (13.41)	53 (16.15)	18 (5.49)
15 (4.57)	NR	NR	NR	NR	15 (4.57)	10 (3.05)	40 (12.19)	51 (15.54)	18 (5.49)
20 (6.10)	NR	NR	NR	NR	20 (6.10)	15 (4.57)	28 (8.53)	40 (12.19)	18 (5.49)

Size 150					Size 200				
H	X	Y	Z	ZH	H	X	Y	Z	ZH
8 (2.44)	6 (1.83)	48 (14.63)	56 (17.07)	12 (3.66)	8 (2.44)	6 (1.83)	50 (15.24)	57 (17.37)	12 (3.66)
10 (3.05)	8 (2.44)	46 (14.02)	54 (16.46)	12 (3.66)	10 (3.05)	8 (2.44)	49 (14.93)	57 (17.37)	12 (3.66)
12 (3.66)	8 (2.44)	49 (14.93)	59 (17.98)	18 (5.49)	12 (3.66)	8 (2.44)	52 (15.85)	61 (18.59)	18 (5.49)
15 (4.57)	11 (3.35)	46 (14.02)	57 (17.37)	18 (5.49)	15 (4.57)	11 (3.35)	47 (14.32)	59 (17.98)	18 (5.49)
20 (6.10)	17 (5.18)	34 (10.36)	47 (14.32)	18 (5.49)	20 (6.10)	17 (5.18)	35 (10.67)	48 (14.63)	18 (5.49)

Size 250					Size 300				
H	X	Y	Z	ZH	H	X	Y	Z	ZH
8 (2.44)	6 (1.83)	50 (15.24)	58 (17.68)	12 (3.66)	8 (2.44)	6 (1.83)	48 (14.63)	56 (17.07)	12 (3.66)
10 (3.05)	7 (2.13)	52 (15.85)	58 (17.68)	12 (3.66)	10 (3.05)	7 (2.13)	50 (15.24)	58 (17.68)	12 (3.66)
12 (3.66)	9 (2.74)	52 (15.85)	61 (18.59)	18 (5.49)	12 (3.66)	9 (2.74)	48 (14.63)	59 (17.98)	18 (5.49)
15 (4.57)	11 (3.35)	47 (14.32)	59 (17.98)	18 (5.49)	15 (4.57)	12 (3.66)	44 (13.41)	57 (17.37)	18 (5.49)
20 (6.10)	18 (5.49)	32 (9.75)	48 (14.63)	18 (5.49)	20 (6.10)	18 (5.49)	32 (9.75)	46 (14.02)	18 (5.49)

Size 350					Size 400				
H	X	Y	Z	ZH	H	X	Y	Z	ZH
8 (2.44)	6 (1.83)	62 (18.90)	69 (21.03)	12 (3.66)	8 (2.44)	6 (1.83)	53 (16.15)	60 (18.29)	12 (3.66)
10 (3.05)	8 (2.44)	61 (18.59)	69 (21.03)	12 (3.66)	10 (3.05)	7 (2.13)	56 (17.07)	63 (19.20)	12 (3.66)
12 (3.66)	8 (2.44)	68 (20.73)	78 (23.77)	18 (5.49)	12 (3.66)	9 (2.74)	54 (16.46)	65 (19.81)	18 (5.49)
15 (4.57)	11 (3.35)	62 (18.90)	73 (22.25)	18 (5.49)	15 (4.57)	12 (3.66)	50 (15.24)	63 (19.20)	18 (5.49)
20 (6.10)	15 (4.57)	53 (16.15)	65 (19.81)	18 (5.49)	20 (6.10)	19 (5.79)	35 (10.67)	51 (15.54)	18 (5.49)

CLEARANCES: Each Gas Unit Heater shall be located with respect to building construction and other equipment so as to permit access to the Unit Heater. Clearance between vertical walls and the vertical sides of the Unit Heater shall be no less than 6 inches (152 mm). However, to ensure access to the burner and power venter compartments, a minimum of 18 inches (457 mm) is required for the control side. A minimum clearance of 6 inches (152 mm) must be maintained between the top of the Unit Heater and the ceiling. The bottom of the Unit Heater must be no less than 6 inches (152 mm) from any combustible. The distance between rear of unit and vertical wall should be no less than 36 inches (914 mm) to maintain inlet air flow. The distance between the flue collector and any combustible must be no less than 6 inches (152 mm). Also see AIR FOR COMBUSTION and VENTING sections.

NOTICE: Increasing the clearance distances may be necessary if there is a possibility of distortion or discoloration of adjacent materials.

▲ WARNING Make certain that the lifting methods used to lift the heater and the methods of suspension used in the field installation of the heater are capable of uniformly supporting the weight of the heater at all times. Failure to heed this warning may result in property damage or personal injury!

▲ WARNING Make sure that the structure to which the unit heater is to be mounted is capable of safely supporting its weight. Under no circumstances must the gas lines, the venting system or the electrical conduit be used to support the heater; or should any other objects (i.e., ladder, person) lean against the heater gas lines, venting system or the electrical conduit for support. Failure to heed these warnings may result in property damage, personal injury, or death.

▲ CAUTION Unit Heaters must be hung level from side to side and from front to back. Failure to do so will result in poor performance and/or premature failure of the unit.

▲ WARNING Ensure that all hardware used in the suspension of each unit heater is more than adequate for the job. Failure to do so may result in extensive property damage, severe personal injury, or death! Washers should not be used between the unit nutsert and jam nut. Use of a washer may cause the nutsert to become dislodged from the unit.

Refer to Figures 3A through 3E for suspension of units.

For unit sizes 250/400, pay special attention to the orientation of the angle mounting brackets per Figures 3B and 3E to ensure brackets sit flush on the bottom of the unit. Note: Angle mounting brackets are provided by the manufacturer for unit sizes 250/400. All other hanging hardware and wood is not included with the unit and should be field supplied.

Figure 3A - High Efficiency Unit Heater Suspension (for sizes 50/200)

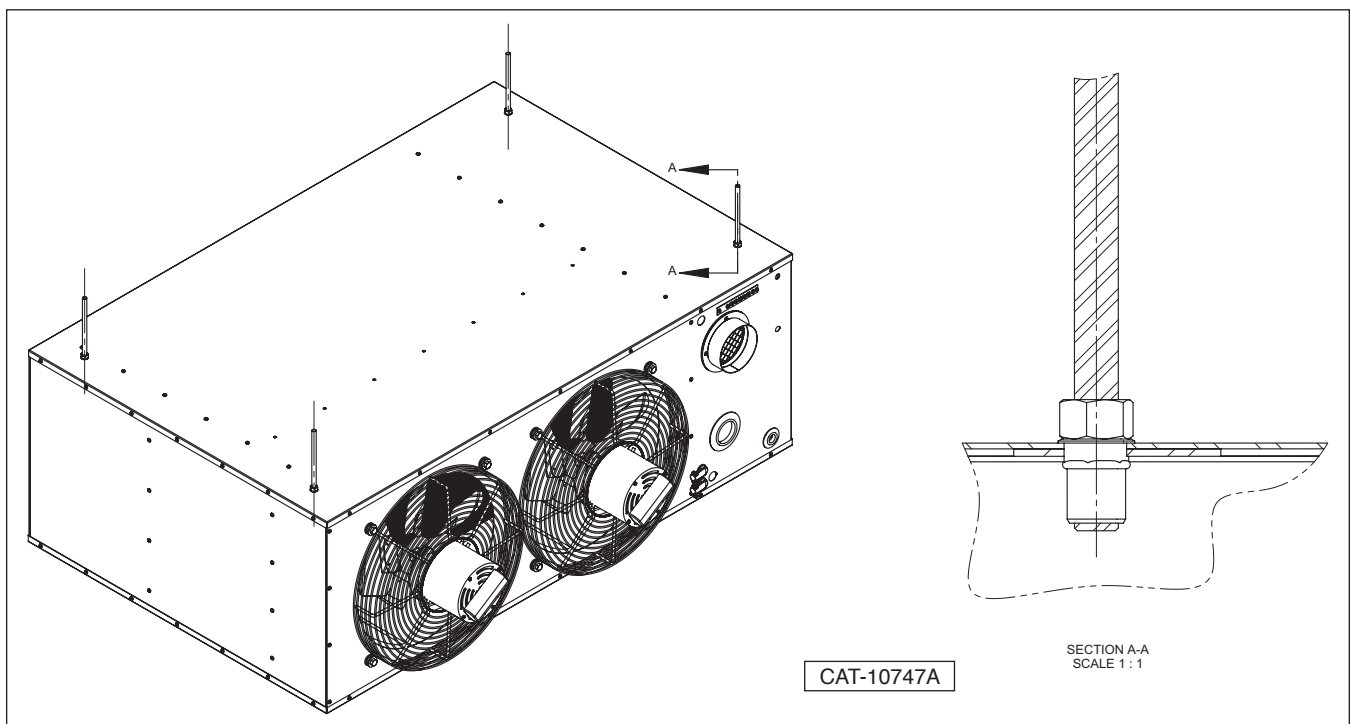

Figure 3B - High Efficiency Unit Heater Suspension (for sizes 250/400)

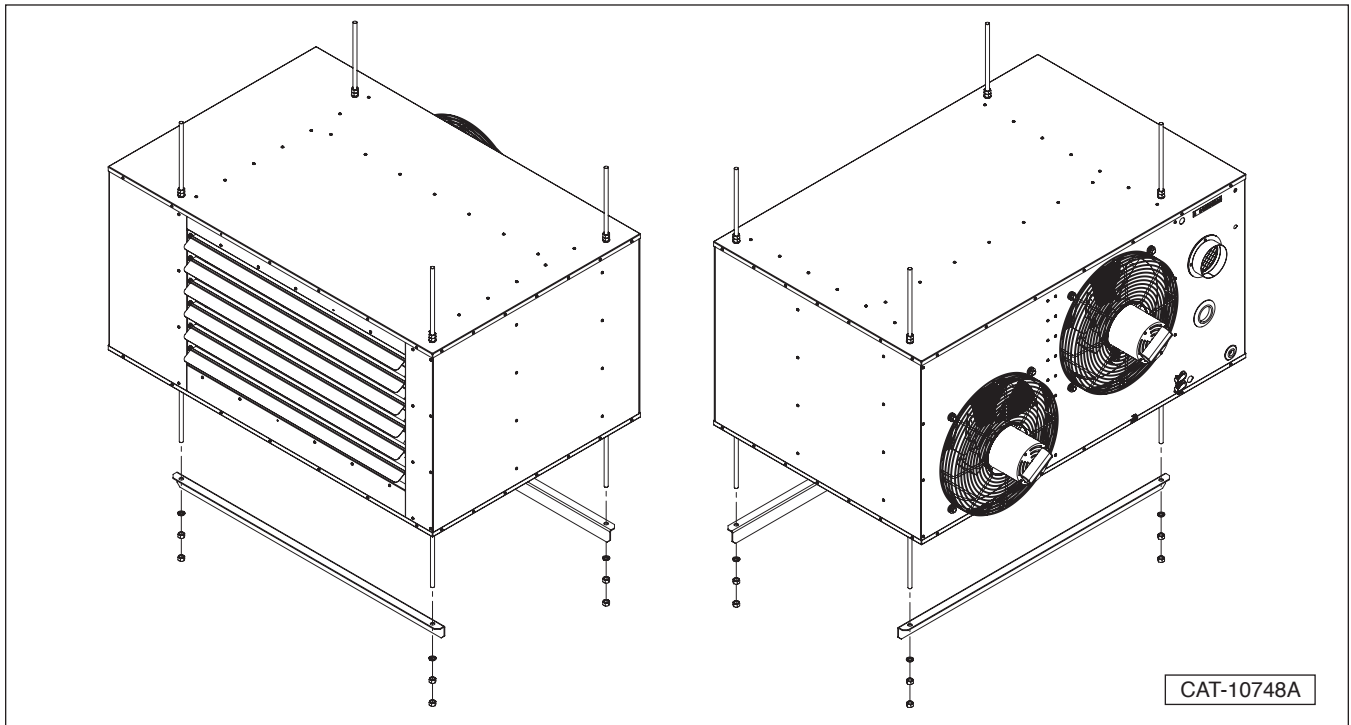

Figure 3C - Heater Mounting: Steel Construction (for all sizes)

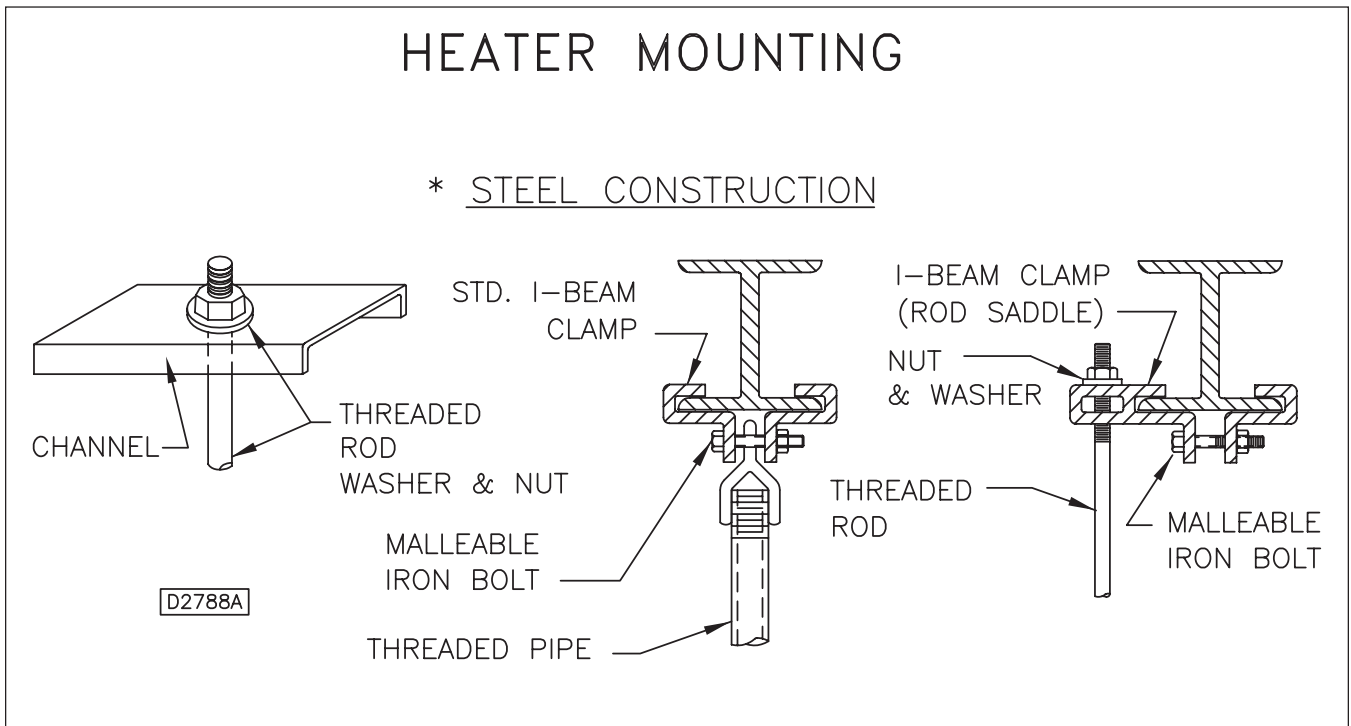

Figure 3D - Heater Mounting: Wood Construction Joists (for sizes 50/200)

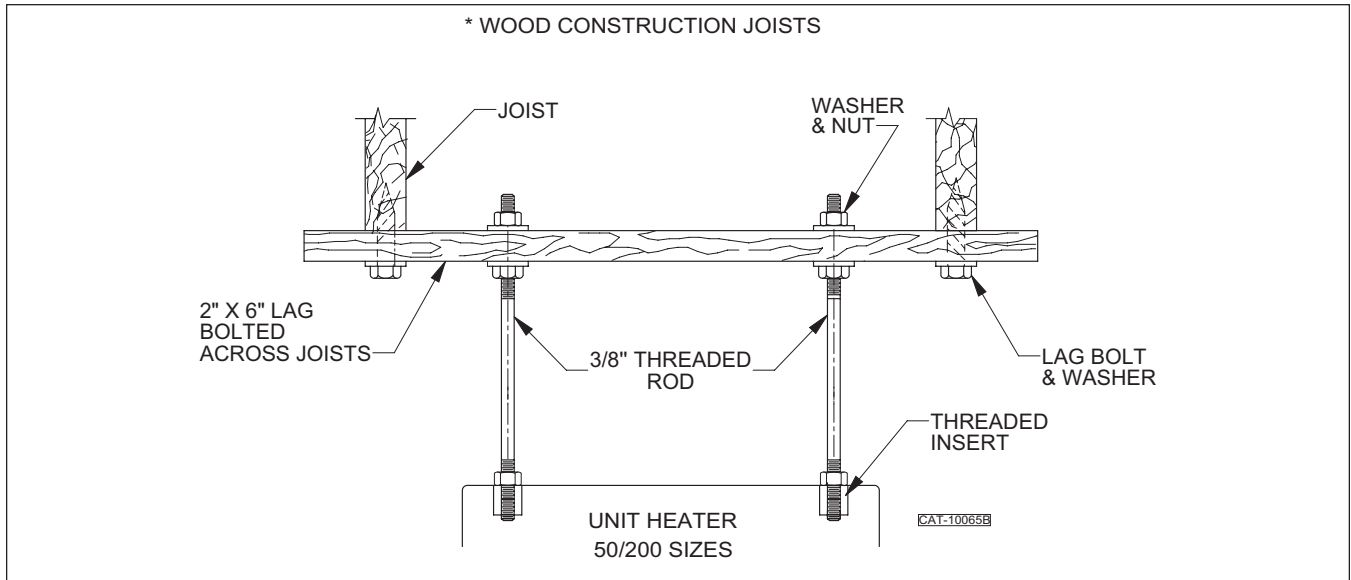
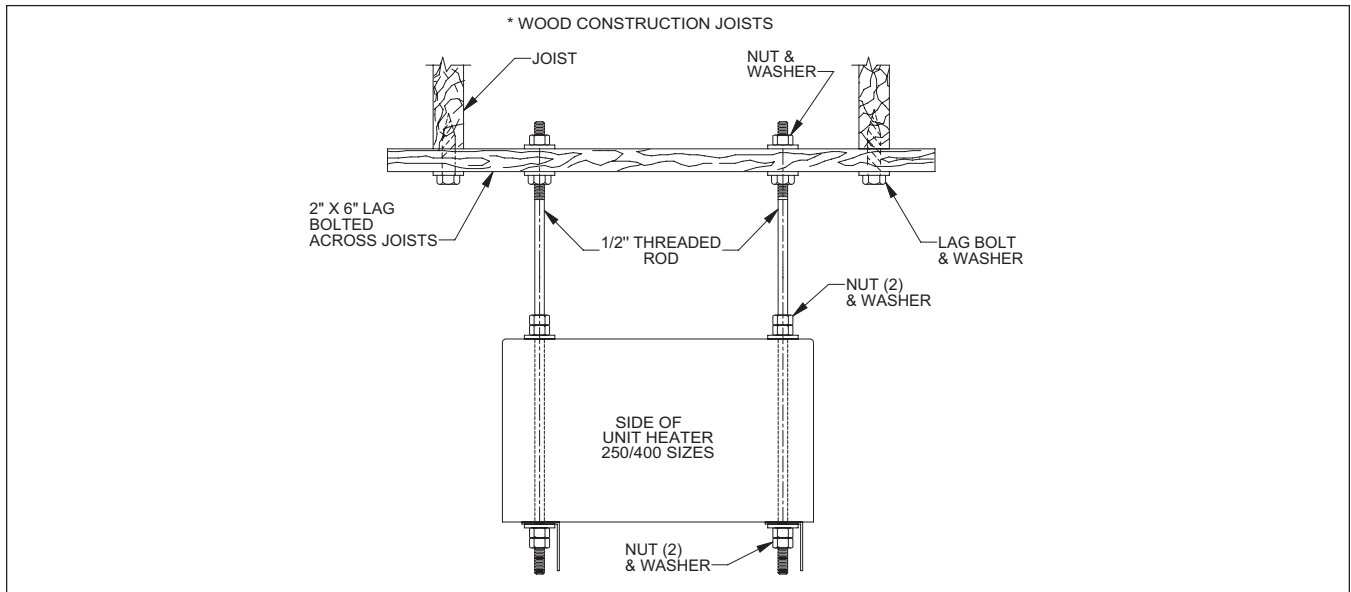

Figure 3E - Heater Mounting: Wood Construction Joists (for sizes 250/400)



*Note: Angle mounting brackets are provided by the manufacturer for unit sizes 250/400. All other hanging hardware and wood is not included with the unit and should be field supplied.

Table 3 - Max. & Min. Mounting Heights

Unit Size	Max Height Feet (m)	Min Height Feet (m)
50	11	N/A*
	(3.4)	
100	14	N/A*
	(4.3)	
150	14	8
	(4.3)	(2.44)
200	20	9
	(6.1)	(2.74)
250	20	9
	(6.1)	(2.74)
300	20	9
	(6.1)	(2.74)
350	20	9
	(6.1)	(2.74)
400	20	9
	(6.1)	(2.74)

*Minimum clearance to combustibles must be maintained; see CLEARANCES section.

INSTALLATION – GAS PIPING

▲ WARNING To avoid damage or possible personal injury, do not connect gas piping to this unit until a supply line pressure/leak test has been completed. Connecting the unit before completing the pressure/leak test may damage the unit gas valve and result in a fire hazard.

▲ WARNING Do not rely on a shut-off valve to isolate the unit while conducting gas pressure/leak tests. These valves may not be completely shut off, exposing the gas valve to excessive pressure and damage.

PIPE SIZING

To provide adequate gas pressure to the gas unit heater, size the gas piping as follows:

1. Find the cu. feet/hr. by using the following formula:

$$\text{Cu. ft./hr.} = \frac{\text{Input BTU/Hr.}}{1000}$$

2. Refer to Table 4. Match “Length of Pipe in Feet” with appropriate “Gas Input - Cu. Feet/Hr.” figure. This figure can then be matched to the pipe size at the top of the column.

Example:

It is determined that a 67 ft. (20.4m) run of gas pipe is required to connect a 200 MBTU gas unit heater to a 1,000 BTU/cu ft. (0.29kW) natural gas supply.

$$\frac{200,000 \text{ BTU/Hr}}{1,000 \text{ BTU/cu. ft.}} = 200 \text{ Cu. ft./hr.}$$

Using Table 4, a 1 inch pipe is needed.

NOTE: See GENERAL SAFETY INFORMATION section for English/Metric unit conversion factors.

NOTICE: If more than one unit heater is to be served by the same piping arrangement, the total cu. ft./hr. input and length of pipe must be considered.

NOTICE: If the gas unit heater is to be fired with LP gas, consult your local LP gas dealer for pipe size information.

NOTICE: HEATER INSTALLATION FOR USE WITH PROPANE (BOTTLED) GAS MUST BE MADE BY A QUALIFIED L.P. GAS DEALER OR INSTALLER. HE/SHE WILL INSURE THAT PROPER JOINT COMPOUNDS ARE USED FOR MAKING PIPE CONNECTIONS; THAT AIR IS PURGED FROM LINES; THAT A THOROUGH TEST IS MADE FOR LEAKS BEFORE OPERATING THE HEATER; AND THAT IT IS PROPERLY CONNECTED TO THE PROPANE GAS SUPPLY SYSTEM.

Before any connection is made to the existing line supplying other gas appliances, contact the local gas company to make sure that the existing line is of adequate size to handle the combined load.

Table 4 - Gas Pipe Size

Maximum Capacity of Pipe in Cubic Feet of Gas per Hour (Cubic Meters per Hour) for Gas Pressures of 0.5 psig (3.5 kPa) or Less, and a Pressure Drop of 0.5 Inch Water Column (124.4 Pa)
(Based on a 0.60 Specific Gravity Gas)

Nominal Iron Pipe Size	Internal Dia. in.	Length of Pipe, Feet (meters)													
		10 (3.0)	20 (6.1)	30 (9.1)	40 (12.2)	50 (15.2)	60 (18.3)	70 (21.3)	80 (24.4)	90 (27.4)	100 (30.5)	125 (38.1)	150 (45.7)	175 (53.3)	200 (61.0)
1/2	0.622	175 (4.96)	120 (3.40)	97 (2.75)	82 (2.32)	73 (2.07)	66 (1.87)	61 (1.73)	57 (1.61)	53 (1.50)	50 (1.42)	44 (1.25)	40 (1.13)	37 (1.05)	35 (0.99)
3/4	0.824	360 (10.2)	250 (7.08)	200 (5.66)	170 (4.81)	151 (4.28)	138 (3.91)	125 (3.54)	118 (3.34)	110 (3.11)	103 (2.92)	93 (2.63)	84 (2.38)	77 (2.18)	72 (2.04)
1	1.049	680 (19.3)	465 (13.2)	375 (10.6)	320 (9.06)	285 (8.07)	260 (7.36)	240 (6.80)	220 (6.23)	205 (5.80)	195 (5.52)	175 (4.96)	160 (4.53)	145 (4.11)	135 (3.82)
1 1/4	1.380	1400 (39.6)	950 (26.9)	770 (21.8)	660 (18.7)	580 (16.4)	530 (15.0)	490 (13.9)	460 (13.0)	430 (12.2)	400 (11.3)	360 (10.2)	325 (9.20)	300 (8.50)	280 (7.93)
1 1/2	1.610	2100 (59.5)	1460 (41.3)	1180 (33.4)	990 (28.0)	900 (25.5)	810 (22.9)	750 (21.2)	690 (19.5)	650 (18.4)	620 (17.6)	550 (15.6)	500 (14.2)	460 (13.0)	430 (12.2)
2	2.067	3950 (112)	2750 (77.9)	2200 (62.3)	1900 (53.8)	1680 (47.6)	1520 (43.0)	1400 (39.6)	1300 (36.8)	1220 (34.5)	1150 (32.6)	1020 (28.9)	950 (26.9)	850 (24.1)	800 (22.7)
2 1/2	2.469	6300 (178)	4350 (123)	3520 (99.7)	3000 (85.0)	2650 (75.0)	2400 (68.0)	2250 (63.7)	2050 (58.0)	1950 (55.2)	1850 (52.4)	1650 (46.7)	1500 (42.5)	1370 (38.8)	1280 (36.2)
3	3.068	11000 (311)	7700 (218)	6250 (177)	5300 (150)	4750 (135)	4300 (122)	3900 (110)	3700 (105)	3450 (97.7)	3250 (92.0)	2950 (83.5)	2650 (75.0)	2450 (69.4)	2280 (64.6)
4	4.026	23000 (651)	15800 (447)	12800 (362)	10900 (309)	9700 (275)	8800 (249)	8100 (229)	7500 (212)	7200 (204)	6700 (190)	6000 (170)	5500 (156)	5000 (142)	4600 (130)

1. Determine the required Cu. Ft./Hr. by dividing the input by 1000. For SI/Metric measurements: Convert BTU/Hr. to kilowatts. Multiply the units inputs (kW) by 0.0965 to determine Cu. Meters./Hr.
2. FOR NATURAL GAS: Select pipe size directly from the table.
3. FOR PROPANE GAS: Multiply the Cu. Ft./Hr. value by 0.633; then, use the table.
4. Refer to the metric conversion factors listed in the General Safety section for SI Unit measurement conversions.

INSTALLATION – GAS PIPING (continued)

PIPE INSTALLATION

1. Install the gas piping in accordance with applicable local codes.
2. A field provided lock-up type high pressure regulator must be used to limit the supply pressure to a maximum of 14 inches W.C. (3.5 kPa). All piping should be sized in accordance with the latest edition of ANSI Standard Z223.1 (NFPA 54), National Fuel Gas Code; in Canada, according to CSA B149. See Table 4 for correct gas piping size. If gas pressure is excessive, install a pressure regulating valve in the line upstream from the main shutoff valve.

NOTICE: For proper operation, unit requires a minimum supply gas pressure of 5 inches W.C. (1.2 kPa) for natural gas or 11 inches W.C. (2.74 kPa) for propane (LP) gas.

3. Adequately support the piping to prevent strain on the gas manifold and controls. Supports should be spaced in accordance with the latest edition of ANSI Standard Z223.1 (NFPA 54), National Fuel Gas Code; in Canada, according to CSA B149.
4. To prevent the mixing of moisture with gas, run the take-off piping from the top, or side, of the main.
5. Gas valve has adjustment ports to adjust flow rate. See START-UP section.
6. Provide a drip leg in the gas piping near the gas unit heater. A ground joint union and a manual gas shutoff valve should be installed ahead of the unit heater controls to permit servicing. The manual shutoff valve must be located external to the jacket (See Figure 4).
7. Make certain that all connections have been adequately doped and tightened.

▲ CAUTION Do not over tighten the inlet gas piping into the valve. This may cause stresses that will crack the valve!

NOTICE: Use pipe joint sealant resistant to the action of liquefied petroleum gases regardless of gas conducted.

▲ WARNING Check all pipe joints for leakage using a soap solution or other approved method. Never use an open flame or severe personal injury or death may occur!

Figure 4 - Pipe Installation, Standard Controls

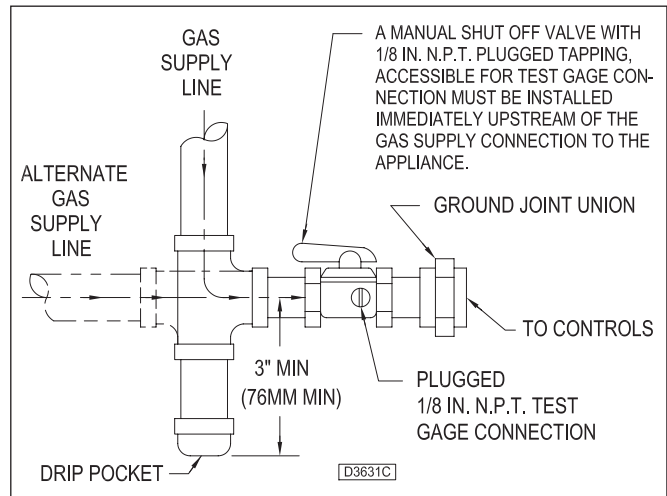

▲ WARNING Never use an open flame to detect gas leaks. Explosive conditions may exist which may result in personal injury or death!

The appliance and its individual shutoff valve must be disconnected from the gas supply piping system during any pressure testing of that system in excess of 1/2 psig (3.5 kPa).

The appliance must be isolated from the gas supply piping system by closing its individual manual shutoff valve during any pressure testing of the gas supply piping system at test pressures equal to or less than 1/2 psig (3.5 kPa).

Table 5 - Gas Piping Requirements

Gas Type		Natural Gas	Propane (LP) Gas
Manifold Pressure			
Single Stage Applications	(inch WC)	3.5	10.0
	(kPa)	(0.87)	(2.49)
Single Stage Size (150 - 400) - Low Fire Adjustment	(inch WC)	1.3	4.0
	(kPa)	(0.3)	(1.0)
Two Stage & Modulating Applications - High Fire Adjustment	(inch WC)	3.5	10.0
	(kPa)	(0.87)	(2.49)
Two Stage & Modulating Applications - Low Fire Adjustment	(inch WC)	0.8	1.8
	(kPa)	(0.20)	(0.45)
Supply Inlet Pressure			
Maximum	(inch WC)	14.0	14.0
	(kPa)	(3.49)	(3.49)
Minimum	(inch WC)	5.0	11.0
	(kPa)	(1.25)	(2.74)

Note: Applicable for units installed at or below 2,000 feet (610 m) altitude. See High Altitude Deration information for altitudes greater than 2,000 feet (610 m)

INSTALLATION – CONDENSATE PIPING

▲ CAUTION The condensate trap provided with the unit must be installed. The condensate trap is designed to provide backpressure for the correct operation of the unit. Do not use a traditional plumbing “P” trap.

▲ WARNING Do not use thread sealing tape in lieu of thread sealant. Parts of the thread sealing tape may break off and prevent the condensate trap from operating properly. This could result in flue gas entering the condensate pipe or nuisance trips.

Figure 5 - Condensate Piping

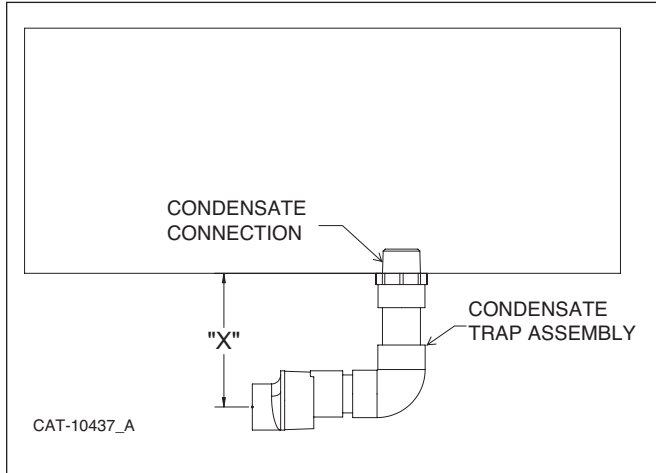

Table 6 - Minimum Condensate Trap Distance

		Size 50	Size 100-300	Size 350- 400
"X" - Minimum Condensate Trap Distance	in.	5-1/6	5-5/8	4-5/8
	mm	131	143	117

Note: The same condensate trap (part number 11264R10822-001) is used for all unit sizes. The connection point inside the unit will vary slightly based on unit size.

1. Remove condensate caution label from condensate connection on bottom of unit.
2. Apply field supplied thread sealant to male threads of condensate trap assembly.
3. Place condensate connection cover and condensate connection gasket over the threaded portion of the condensate trap assembly. The gasket should be on the side closest to the unit.

4. Screw condensate trap assembly into condensate connection.
5. Push the condensate connection cover and gasket tight to the unit and screw the cover plate into the bottom panel with the provided screws.
6. Connect the bottom of the condensate trap assembly to the rest of the condensate drain system.

NOTICE: Condensate drain system should be pitched away from the unit towards the condensate drain. If not possible due to space requirements, a condensate pump can be used to mechanically assist with condensate drainage. Condensate pipe should be sized based on the total volume of condensate that may flow through it (this includes the total volume of all units if multiple units are connected to a single condensate drain system).

NOTICE: Condensate is acidic; refer to local plumbing and mechanical codes for proper neutralizer and disposal requirements.

7. Check for leaks when unit is operating and producing condensate.

Optional condensate pump, pump-shelf, and condensate neutralizers are available and should be installed per their separate corresponding installation manuals.

ELECTRICAL CONNECTIONS



▲ WARNING
HAZARDOUS VOLTAGE!
DISCONNECT ALL ELECTRIC POWER INCLUDING REMOTE DISCONNECTS BEFORE SERVICING. Failure to disconnect power before servicing can cause severe personal injury or death.

Standard units are shipped for use on 115 volt, 60 hertz, single phase electric power. The motor nameplate and electrical rating of the transformer should be checked before energizing the unit heater electrical system. All external wiring must conform to the latest edition of ANSI/NFPA No. 70, United States National Electrical Code, and applicable local codes; in Canada, to the Canadian Electrical Code, Part 1, CSA Standard C22.1.

The short-circuit current rating (SCCR) for this unit is 5kA.

▲ WARNING Field installed step-down transformers provided for units with non-standard supply voltage options 2-7 (any voltage other than 115/1/60) cannot be mounted on the unit due to the weight of the transformer. The step-down transformer should be mounted elsewhere and wired to the unit accordingly. Failure to do so could result in fatal electric shock or severe personal injury.

▲ CAUTION Do not use any tools (i.e., screwdriver, pliers, etc.) across terminals to check for power. Use a voltmeter.

It is recommended that the electrical power supply to each unit heater be provided by a separate, fused, and permanently live electrical circuit. A disconnect switch of suitable electrical rating should be located as close to the gas valve and controls as possible. Each unit heater must be electrically grounded in accordance with the latest edition of the United States National Electrical Code, ANSI/NFPA No. 70, or CSA Standard C22.1.

THERMOSTAT WIRING AND LOCATION:

NOTICE:The thermostat must be mounted on a vertical, vibration-free surface, free from air currents, and in accordance with the furnished instructions.

Mount the thermostat approximately 5 feet (1.5 m) above the floor, in an area where it will be exposed to a free circulation of average temperature air. Always refer to the thermostat instructions, as well as our unit wiring diagram, and wire accordingly. Avoid mounting the thermostat in the following locations:

1. Cold Areas - Outside walls or areas where drafts may affect the operation of the control.

2. Hot Areas - Areas where the sun's rays, radiation, or warm air currents may affect the operation of the control.
3. Dead Areas - Areas where the air cannot circulate freely, such as behind doors or in corners.

Figure 6A - Low-voltage Thermostat Wiring, Single Stage

LOW-VOLTAGE
SINGLE STAGE
THERMOSTAT

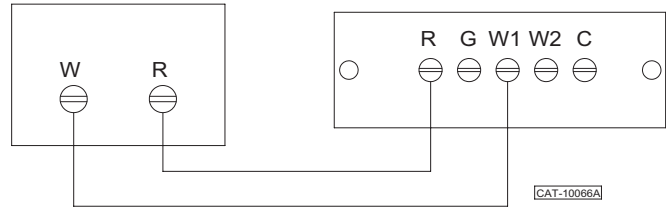

Figure 6B – Low-voltage w/Fan Switch Thermostat Wiring, Single Stage

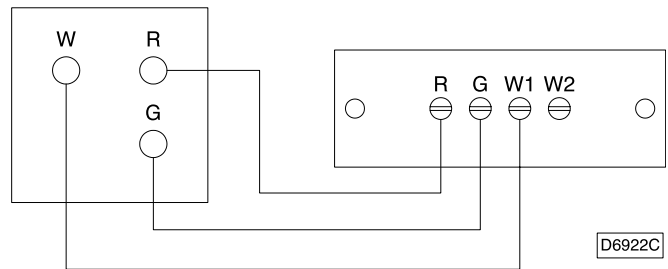
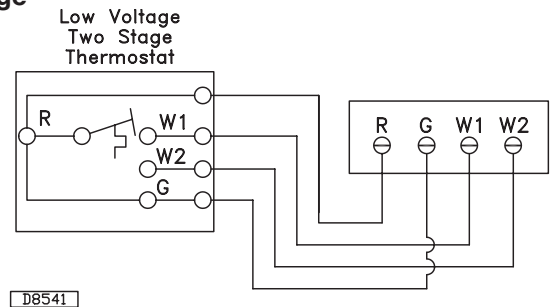

Figure 6C – Low-voltage Thermostat Wiring, Two Stage



NOTICE: From a cold start, the start-up fan delay should not exceed 30 seconds from after flame sensing.

IMPORTANT: For all wiring connections, refer to the wiring diagram shipped with your unit (either affixed inside the control box access panel or enclosed in the installation instructions envelope). Should any original wire supplied with the heater have to be replaced, it must be replaced with wiring material having a temperature rating of at least 105°C.

Should any high limit wires have to be replaced, they must be replaced with wiring material having a temperature rating of 200°C minimum.

ELECTRICAL CONNECTIONS (continued)

Figure 7A – Unit Wiring Diagram, High Efficiency Gas-Fired Propeller Unit Heater Size 50, Equipped with Natural Gas or Propane (LP) Gas, Single Stage

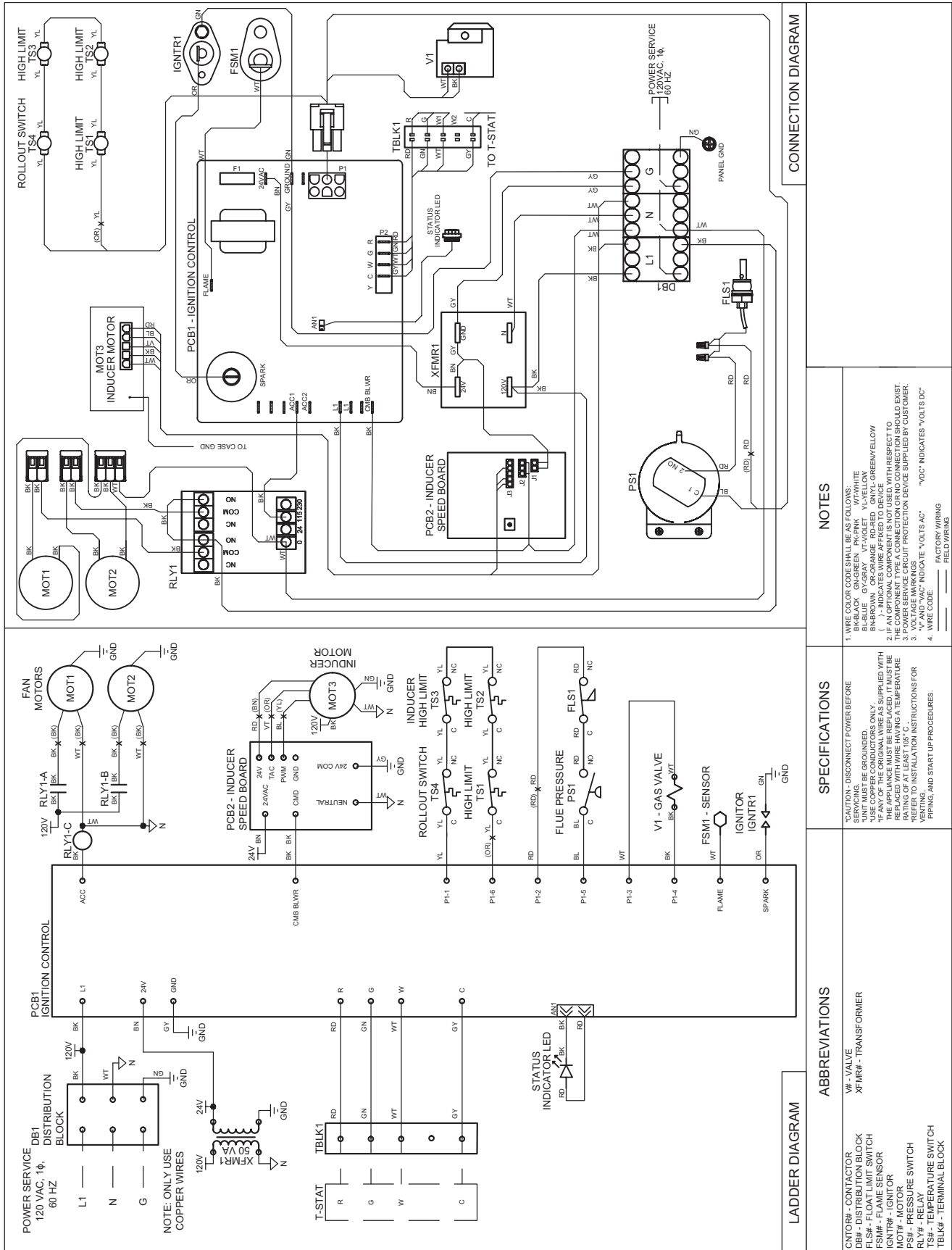

ELECTRICAL CONNECTIONS (continued)

Figure 7B – Unit Wiring Diagram, High Efficiency Gas-Fired Propeller Unit Heater Size 100, Equipped with Natural Gas or Propane (LP) Gas, Single Stage

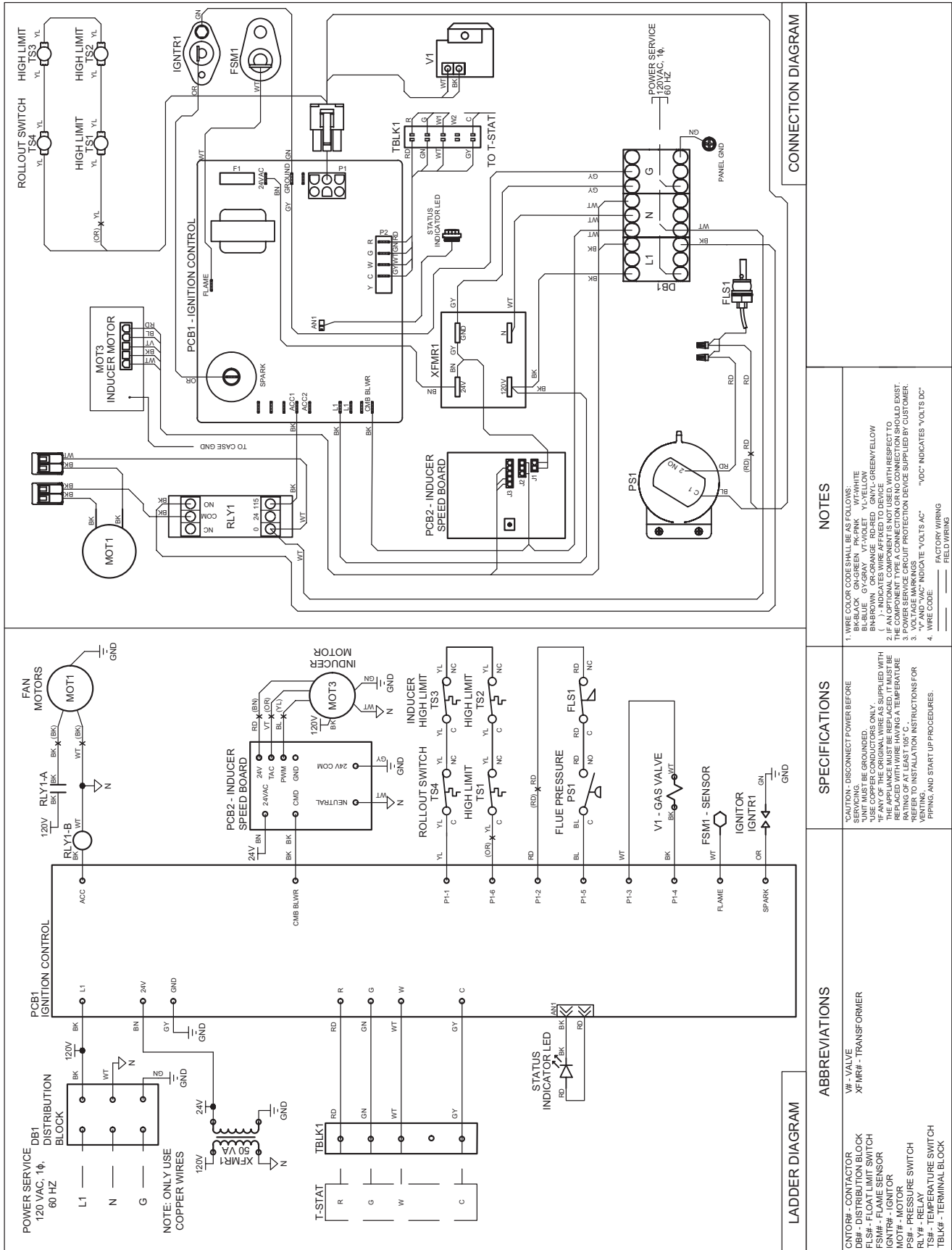

ELECTRICAL CONNECTIONS (continued)

Figure 7C – Unit Wiring Diagram, High Efficiency Gas-Fired Propeller Unit Heater Size 150, Equipped with Natural Gas or Propane (LP) Gas, Single Stage

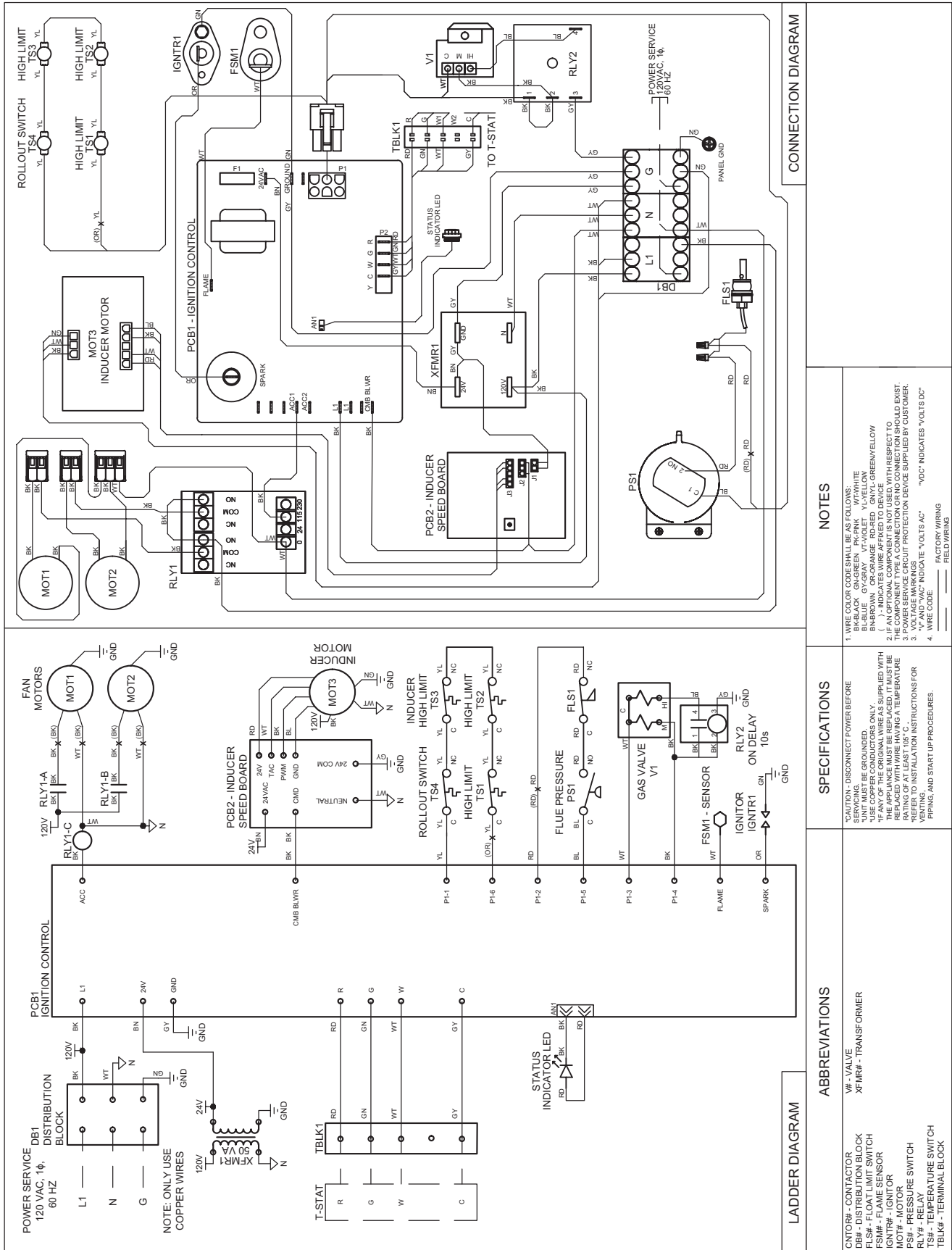

ELECTRICAL CONNECTIONS (continued)

Figure 7D – Unit Wiring Diagram, High Efficiency Gas-Fired Propeller Unit Heater Size 200, Equipped with Natural Gas or Propane (LP) Gas, Single Stage

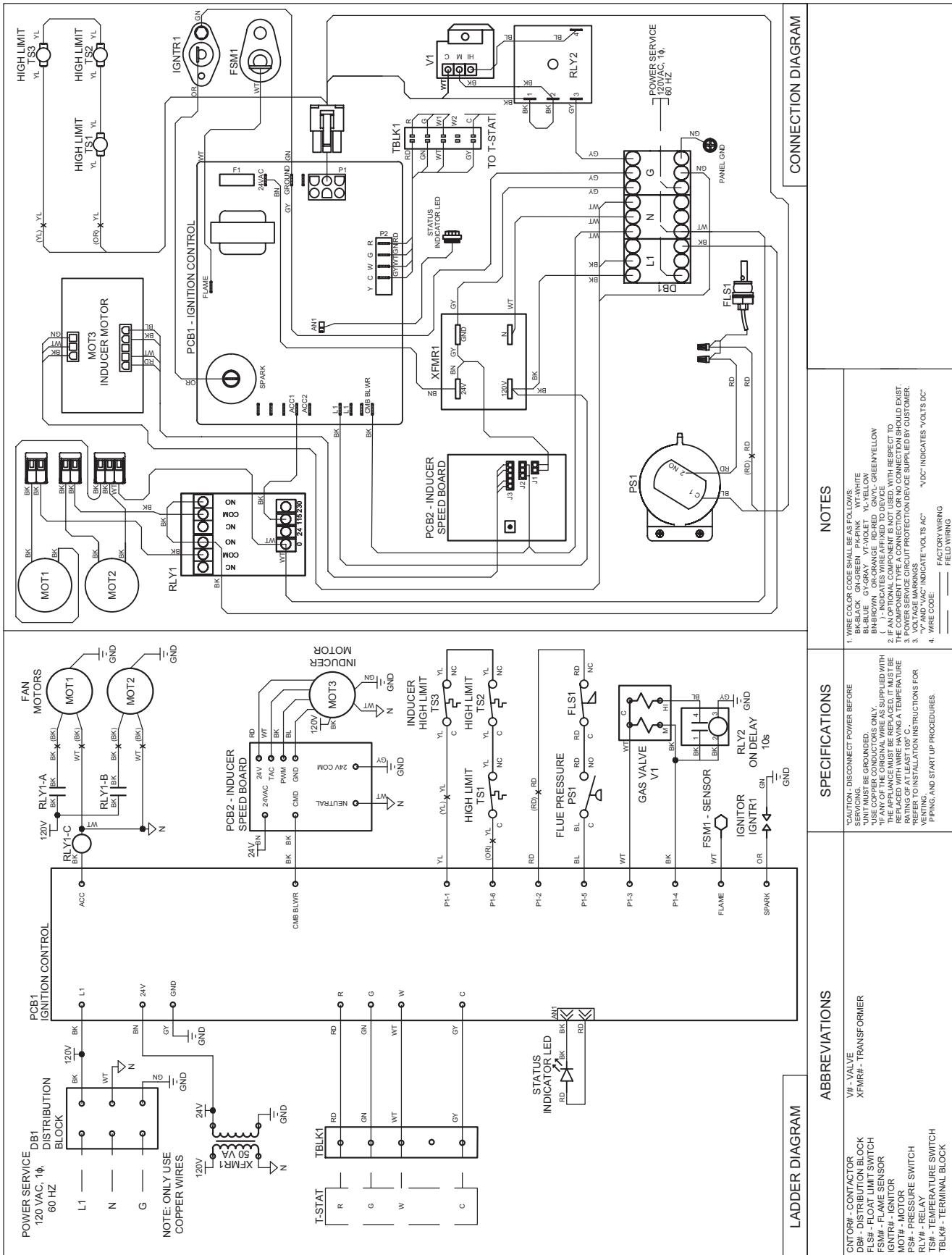

CONNECTION DIAGRAM

NOTES

1. WIRE COLOR CODE SHALL BE AS FOLLOWS:
BK-BLACK GN-GREEN PK-PINK WT-WHITE
BL-BLUE GY-GRAY VT-VIOLET YL-YELLOW
OR-ORANGE RD-RED GR-GRAND GREEN
C-COMMON
-INDICATES WIRE AFFIXED TO DEVICE
-INDICATES WIRE SUPPLIED BY USER
2. IF AN OPTIONAL COMPONENT IS NOT USED, WITH RESPECT TO THE COMPONENT, A CONNECTION OR NO CONNECTION SHOULD EXIST.
3. VOLTAGE MARKINGS
"V" AND "VAC" INDICATE "VOLTS AC" "VDC" INDICATES "VOLTS DC"
4. WIRE CODE: _____ FACTORY WIRING
_____ FIELD WIRING

SPECIFICATIONS

- CAUTION: DISCONNECT POWER BEFORE SERVICING.
- UNIT MUST BE GROUNDED.
- WIRING SHALL BE ACCORDING TO LOCAL AND NATIONAL ELECTRICAL CODES ONLY.
- IF ANY OF THE ORIGINAL WIRES AS SUPPLIED WITH THE APPLIANCE MUST BE REPLACED, IT MUST BE REPLACED WITH WIRE HAVING A TEMPERATURE RATING AT LEAST EQUAL TO THAT OF THE ORIGINAL WIRE.
- REFER TO INSTALLATION INSTRUCTIONS FOR VENTING, AND START UP PROCEDURES.

ABBREVIATIONS

- V# - VALVE
- XFRM# - TRANSFORMER
- CON - CONTACTOR
- DB# - DISTRIBUTION BLOCK
- FLS# - FLOAT LIMIT SWITCH
- FSM# - FLAME SENSOR
- IGNTR# - IGNITOR
- MOT# - MOTOR
- PS# - PRESSURE SWITCH
- RLY# - RELAY
- SP - TEMPERATURE SWITCH
- TBLK# - TERMINAL BLOCK

LADDER DIAGRAM

ELECTRICAL CONNECTIONS (continued)

Figure 7E – Unit Wiring Diagram, High Efficiency Gas-Fired Propeller Unit Heater Sizes 250/400, Equipped with Natural Gas or Propane (LP) Gas, Single Stage

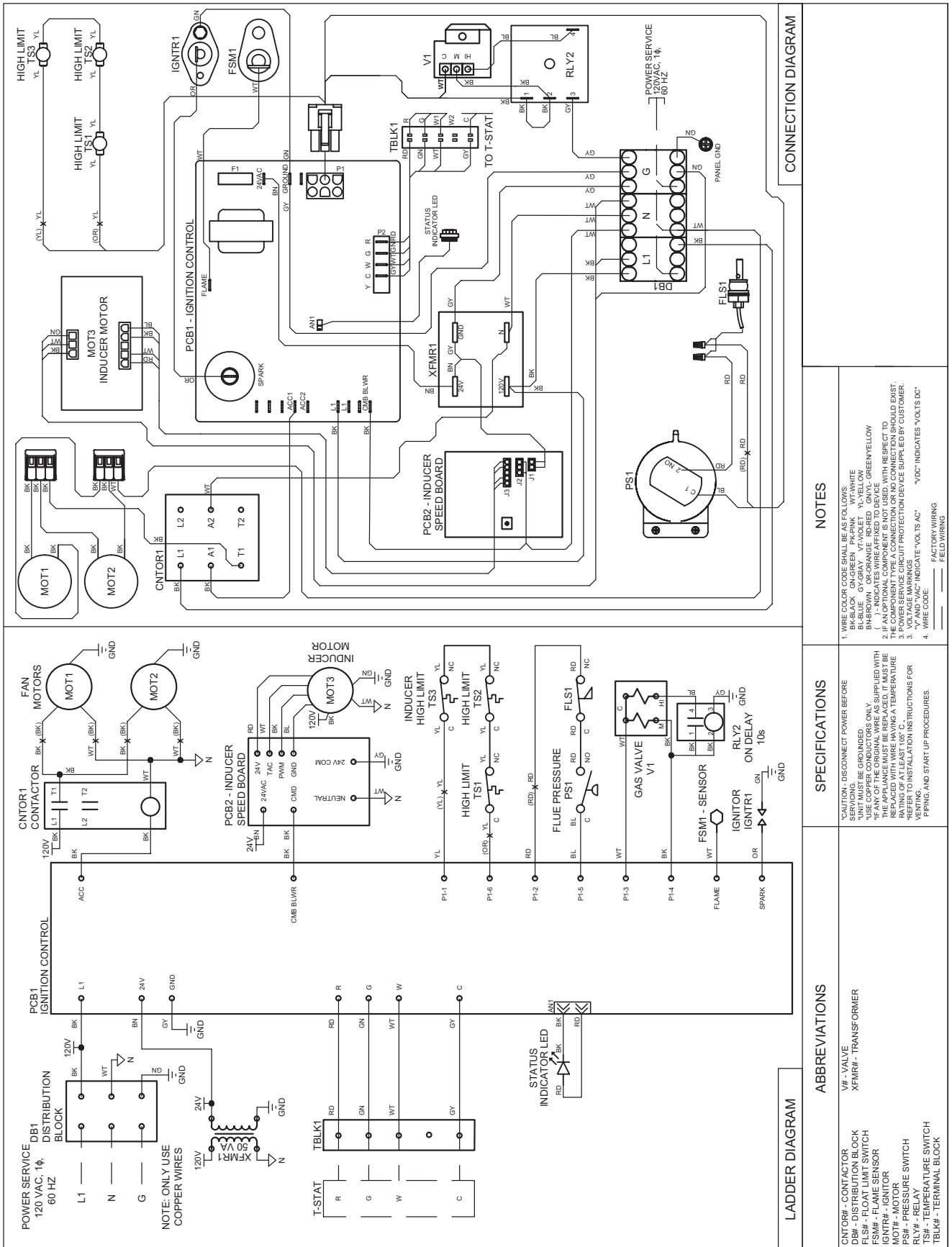

CONNECTION DIAGRAM

NOTES

1. WIRE COLOR CODE SHALL BE AS FOLLOWS:
 BK-BLACK GN-GREEN PK-PINK WT-WHITE
 BL-BLUE GY-GRAY VT-VIOLET YL-YELLOW
 BK-BLUE GY-GRAY VT-VIOLET YL-YELLOW
 C-INDICATES WIRE AFFIXED TO DEVICE
 ()-INDICATES WIRE NOT SUPPLIED BY USER
 2. IF AN OPTIONAL COMPONENT IS NOT USED, WITH RESPECT TO THE COMPONENT, A CONNECTION OR NO CONNECTION SHOULD EXIST.
 3. VOLTAGE MARKINGS "V" AND "VAC" INDICATE "VOLTS AC" "VDC" INDICATES "VOLTS DC"
 4. WIRE CODE: _____ FACTORY WIRING
 _____ FIELD WIRING

SPECIFICATIONS

- CAUTION: DISCONNECT POWER BEFORE SERVICING.
- UNIT MUST BE GROUNDED.
- WIRING SHALL BE ACCORDING TO LOCAL AND NATIONAL ELECTRICAL CODES ONLY.
- IF ANY OF THE ORIGINAL WIRES AS SUPPLIED WITH THE APPLIANCE MUST BE REPLACED, IT MUST BE REPLACED WITH WIRE HAVING A TEMPERATURE RATING AT LEAST EQUAL TO THAT OF THE ORIGINAL WIRE.
- REFER TO INSTALLATION INSTRUCTIONS FOR VENTING, AND START UP PROCEDURES.

ABBREVIATIONS

- CNT# - CONTACTOR
- DB# - DISTRIBUTION BLOCK
- FLS# - FLOAT LIMIT SWITCH
- FSM# - FLAME SENSOR
- IGNTR# - IGNITOR
- MOT# - MOTOR
- PS# - PRESSURE SWITCH
- RLY# - RELAY
- SP# - TEMPERATURE SWITCH
- TBLK# - TERMINAL BLOCK
- V# - VALVE
- XFR# - TRANSFORMER

LADDER DIAGRAM

VENTING – GENERAL GUIDELINES

ANSI now organizes vented appliances into four categories.

Venting Categories

	Non- Condensing	Condensing
Negative Vent Pressure	I	II
Positive Vent Pressure	III	IV

Category I

Includes non-condensing appliances with negative vent pressure, like the traditional atmospheric unit heater.

Category II

Groups condensing appliances with negative vent pressure.

Category III

Appliances are non-condensing and operate with a positive vent pressure.

Category IV

Covers condensing appliances with positive vent pressure.

NOTICE: Category I, II and III do not apply to equipment specified within this manual. These unit heaters are Category IV appliances.

All unit heaters must be vented! All Venting installations shall be in accordance with the latest edition of Part 7, Venting of Equipment of the National Fuel Gas Code, ANSI Z223.1 (NFPA 54), or applicable provisions of local building codes.

The following instructions apply to Canadian installations in addition to installation and operating instructions:

1. Installation must conform with local building codes, or in the absence of local codes, with current CSA B149.1, Installation Codes for Natural Gas Burning Appliances and Equipment, or CSA B149.2, Installation Codes for Propane Gas Burning Appliances and Equipment.
2. Any reference to U.S. standards or codes in these instructions are to be ignored, and the applicable Canadian standards or codes applied.

▲ WARNING **CARBON MONOXIDE! Your venting system must not be blocked by any snow, snow drifts, or any foreign matter. Inspect your venting system to ensure adequate ventilation exists at all times! Failure to heed these warnings could result in Carbon Monoxide Poisoning (symptoms include grogginess, lethargy, inappropriate tiredness, or flu-like symptoms).**

Each unit must have an individual vent pipe and vent terminal! Each unit MUST NOT be connected to other vent systems or to a chimney.

Do not damper or add heat recovery devices to the flue piping. Failure to open such a damper prior to operating gas unit will result in the spillage of flue gas into the occupied space.

NOTICE: The high efficiency unit heater is likely to produce a vapor plume due to condensation. Surfaces near the vent termination will likely become coated with condensation.

▲ CAUTION **Condensing flue gases can freeze on exterior building surfaces which may cause discoloration and degradation of the surfaces.**

FLUE PIPE COUPLING AND REDUCER

All unit sizes ship with a rubber flue pipe coupling factory installed on the power venter. This coupling should be oriented so condensate connections are on the bottom of the coupling. There is also an arrow printed on the coupling showing the flue gas airflow direction.

In addition to the rubber flue pipe coupling, some sizes ship with an additional field installed fitting that requires installation:

Size 150 – 2" to 3" PVC reducer

Size 200-300 – 2" to 4" PVC reducer

The reducer must be installed in a horizontal section of the flue pipe system within 12 inches (305 mm) of the unit. All vent pipe joints and seams must be sealed to prevent leakage. All joints must be cleaned prior to assembly. Joints should then be primed in accordance with ASTM F 656. After priming, joints should be cemented per ASTM D 2564.

Size 350-400 – 2" to 4" PVC drain tee fitting

The drain tee must be installed in a horizontal section of the flue pipe system within 12 inches (305 mm) of the unit with the drain pointing downward. The condensate tubing will ship connected to the flue collector coiled inside the power venter compartment. The tubing should be uncoiled and connected to the bottom of the condensate drain tee. All vent pipe joints and seams must be sealed to prevent leakage. All joints must be cleaned prior to assembly. Joints should then be primed in accordance with ASTM F 656. After priming, joints should be cemented per ASTM D 2564.

VENTING – GENERAL GUIDELINES

Table 7 - Vent Systems Termination Clearance Requirements

Structure/Object	Minimum Clearance for Termination Locations	
	USA	CANADA
Door, window, or gravity vent inlet; combustion air inlet for other appliances	9 in. for 10,000 to 50,000 BTU/Hr input; 12 in. for input exceeding 50,000 BTU/Hr.	9 in. (230mm) for 10,000 to 50,000 BTU/Hr input; 12 in. (305mm) for input exceeding 50,000 BTU/Hr.
Forced air inlet within 10 ft.	3 ft. above	6 ft. (1.8m)
Adjoining building or parapet ¹	10 ft.	10 ft. (3.04m)
Adjacent public walkways	7 ft. above grade	7 ft. (2.1m) above grade
Electric, gas meters & regulators	4 ft. horizontal	3 ft. (0.9m) horizontally from meter/regulator assembly. 6 ft. (1.8m), any direction, from a gas service regulator vent outlet
Above grade level ²	1 ft.	1 ft. (0.3m)

Notes:

1. For USA installations: Per NFPA 54, sections 12.6.2.1 and 12.7.2.1a, buildings are required to be a minimum of 10 feet (3.05 m) from the flue termination. When using B-vent in a Category I applications, this clearance can be reduced to 8 feet (2.44 m).

For Canadian installations: Per CSA B149.1 sections 8.14.2, 8.14.3, and 8.14.5, buildings are required to be a minimum of 10 feet (3.05 m) from the flue termination in a Category I application, and a minimum of 6 feet (1.8 m) in a Category III application.

2. Minimum above maximum snow depth, or per local code, whichever is greater.

STANDARD COMBUSTION – HORIZONTALLY VENTED UNIT HEATERS (CATEGORY IV)

▲ WARNING This appliance uses a positive pressure venting system. All joints must be sealed completely to prevent leakage of flue products into occupied spaces. Failure to do this may result in severe personal injury, death or major property damage.

- Horizontal venting arrangements are designed to be used with schedule 40 vent pipe. All heaters should be vented with UL 1738 listed vent pipe. For installations in Canada, use corrosion resistant and gas-tight, listed vent pipe conforming with local building codes, or in the absence of local building codes, with the current CSA-B149.1, Installation Codes for natural Gas Burning Appliances and Equipment or CSA-B149.2, Installation Codes for Propane Gas Burning Appliances and Equipment. Approved vent pipe includes but is not limited to: ULC-S636 PVC or CPVC Vent pipe. Vent pipe must be rated for up to 140°F (60°C) operating temperature. Type B vent should not be used.

▲ WARNING Do not use Type B (double wall) vent internally within the building on high efficiency unit heaters! This can result in death, serious injury or substantial property damage.

▲ WARNING Use of cellular core pipe for any exhaust vent component is prohibited. Use of cellular core pipe may result in severe personal injury, death, or major property damage.

NOTICE: Installations in Canada require compliance with ULC-S636 Standard for Type BH Gas Venting Systems.

NOTICE: If state or local code do not allow for the use of a PVC vent pipe, flue pipe material must comply with local code requirements.

a) If allowed by local code, field provided UL-S636 listed, polypropylene gas vent pipe can be used. See Table 8 for approved supplier/models.

b) If metal vent pipe is required by local code, field provided UL 1738 listed, single or double wall vent pipe can be used. See Table 8 for approved supplier/models.

- The vent pipe diameter MUST be as specified (see Table 1). All unit sizes are factory equipped with the required flue size collar; attach in place (if not already factory-mounted to outlet). See FLUE PIPE COUPLING AND REDUCER section for details.
- The vent pipe equivalent length must not exceed 50 feet (15.2 m). Equivalent length is total length of straight sections PLUS 5 feet (1.5 m) for each 90 degree elbow and 2.5 feet (0.76 m) for each 45 degree elbow.
- A minimum horizontal run of 12 inches (305 mm) is required between the unit's flue vent connection and first elbow.

- Vent shall be terminated with a 90 degree elbow or tee. The vent terminal must be at least 12 inches (305 mm) from the exterior of the wall that it passes through to prevent degradation of the building material by flue gases. Through the wall vent for these appliances shall NOT terminate over public walkways, or over an area where the condensate or vapor could create a nuisance or hazard or could be detrimental to the operation of regulators, relief valves, or other equipment. See Table 7 for termination clearance requirements.
- The vent system must be installed to prevent collection of condensate. Pitch horizontal pipes downward 1/4 inch per foot (21 mm/m) toward the unit for condensate drainage.
- Horizontal portions of the venting systems shall be supported at maximum intervals of 4 feet (1.2 m) to prevent sagging (in Canada, support at 3 feet (1 m) maximum intervals).
- Seal all vent pipe joints and seams to prevent leakage. All joints must be cleaned prior to assembly. Joints should then be primed in accordance with ASTM F 656. After priming, joints should be cemented per ASTM D 2564.
- Insulate single wall vent pipe exposed to cold air or running through unheated areas.
- Each unit must have an individual vent pipe and vent terminal!** Each unit MUST NOT be connected to other vent systems or to a chimney. A field provided stainless steel screen may be placed on the end of the flue pipe to prevent animals from entering the venting system.

Figure 8 – Horizontal Venting, Standard Combustion

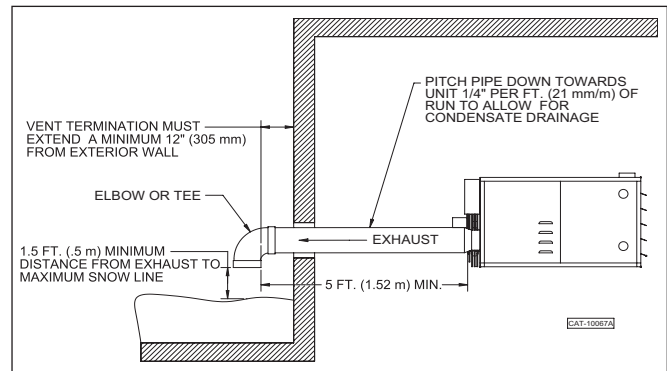

NOTICE: Increasing the vent termination clearance distances may be necessary if there is a possibility of distortion or discoloration of adjacent materials.

Table 8 - Approved Alternate Flue Vent Pipe Materials

	Brand	Model
Polypropylene Gas Vent Pipe	Duravent	Polypro
	Centrotherm	InnoFlue
	Selkirk	Polyflue
Single Wall Vent Pipe	Duravent	FasNSeal
	Metal-Fab	Corr/Guard
	Selkirk	HeatFab Saf-T Vent EZ
Double Wall Vent Pipe	Duravent	FasNSeal W2
	Metal-Fab	Corr/Guard
	Selkirk	HeatFab Saf-T Vent CI Plus*

*Not available in 3" diameter

STANDARD COMBUSTION – VERTICALLY VENTED UNIT HEATERS (CATEGORY IV)

▲ WARNING This appliance uses a positive pressure venting system. All joints must be sealed completely to prevent leakage of flue products into occupied spaces. Failure to do this may result in severe personal injury, death or major property damage.

1. Vertical venting arrangements are designed to be used with schedule 40 vent pipe. All heaters should be vented with UL 1738 listed vent pipe. For installations in Canada, use corrosion resistant and gas-tight, listed vent pipe conforming with local building codes, or in the absence of local building codes, with the current CSA-B149.1, Installation Codes for natural Gas Burning Appliances and Equipment or CSA-B149.2, Installation Codes for Propane Gas Burning Appliances and Equipment. Approved vent pipe includes but is not limited to: ULC-S636 PVC or CPVC Vent pipe. Vent pipe must be rated for up to 140°F (60°C) operating temperature. Type B vent should not be used.

▲ WARNING Do not use Type B (double wall) vent internally within the building on high efficiency unit heaters! This can result in death, serious injury or substantial property damage.

▲ WARNING Use of cellular core pipe for any exhaust vent component is prohibited. Use of cellular core pipe may result in severe personal injury, death, or major property damage.

NOTICE: Installations in Canada require compliance with ULC-S636 Standard for Type BH Gas Venting Systems

NOTICE: If state or local code do not allow for the use of a PVC vent pipe, flue pipe material must comply with local code requirements.

a) If allowed by local code, field provided UL-S636 listed, polypropylene gas vent pipe can be used. See Table 8 for approved supplier/models.

b) If metal vent pipe is required by local code, field provided UL 1738 listed, single or double wall vent pipe can be used. See Table 8 for approved supplier/models.

2. The vent pipe diameter MUST be as specified (see Table 1). All unit sizes are factory equipped with the required flue size collar; attach in place (if not already factory-mounted to outlet). See FLUE PIPE COUPLING AND REDUCER section for details.
3. The top of the vent pipe should extend at least 2 feet (0.61 m) above the highest point on the roof within 10 feet (3.05 m) of the termination. Consideration should be made for anticipated snow depth.

4. Vent shall be terminated with a 180 degree elbow or two 90 degree elbows. Vent system terminations for these appliances shall NOT terminate in an area where the condensate or vapor could create a nuisance or hazard or could be detrimental to the operation of regulators, relief valves, or other equipment. See Table 7 for termination clearance requirements.
5. The vent pipe equivalent length must not exceed 50 feet (15.2 m). Equivalent length is total length of straight sections PLUS 5 feet (1.5 m) for each 90 degree elbow and 2.5 feet (0.76 m) for each 45 degree elbow.
6. A minimum horizontal run of 12 inches (305 mm) is required between the unit's flue vent connection and first elbow.
7. Seal all vent pipe joints and seams to prevent leakage. All joints must be cleaned prior to assembly. Joints should then be primed in accordance with ASTM F 656. After priming, joints should be cemented per ASTM D 2564. The vent system must be installed to prevent collection of condensate. Pitch horizontal pipes downward 1/4 inch per foot (21 mm/m) toward the unit for condensate drainage.
8. Horizontal portions of the venting systems shall be supported at maximum intervals of 4 feet (1.2 m) to prevent sagging (in Canada, support at 3 feet (1 m) maximum intervals).
9. Insulate single wall vent pipe exposed to cold air or running through unheated areas.
10. **Each unit must have an individual vent pipe and termination.** Each unit MUST NOT be connected to other vent systems or to a chimney. A field provided stainless steel screen may be placed on the end of the flue pipe to prevent animals from entering the venting system.

Figure 9 – Vertical Venting, Standard Combustion

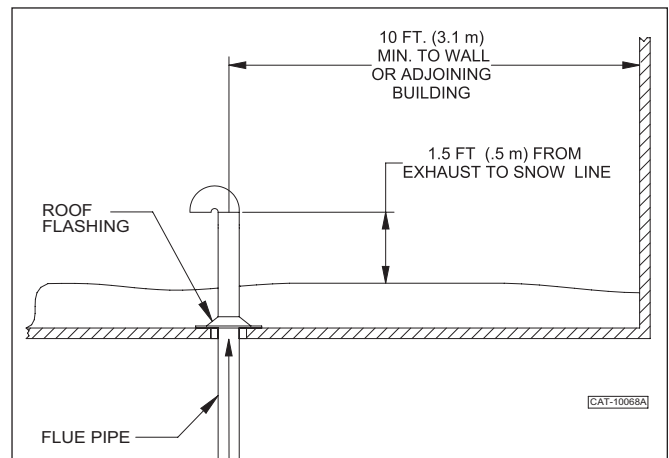

SEPARATED COMBUSTION – TWO PIPE VENTING

NOTE: For non-concentric venting (two wall or two roof penetrations, one for combustion air and a second for flue pipe), follow the instructions below. For concentric venting (single wall or roof penetration), follow the concentric venting instructions in SEPARATED COMBUSTION – CONCENTRIC VENTING Section.

AIR INLET COLLAR

When unit is to be used in a separated vent system, the inlet collar located on the rear panel of the unit will be connected to the combustion air intake pipe. This connection is made by using the appropriate size rubber coupling (field provided) for each size unit. The coupling is installed so that air inlet pipe can be detached from the unit for serviceability purposes.

COMBUSTION AIR VENTING AND PIPING

▲ WARNING CARBON MONOXIDE!

Your venting system must not be blocked by any snow, snow drifts, or any foreign matter. Inspect your venting system to ensure adequate ventilation exists at all times! Failure to heed these warnings could result in Carbon Monoxide Poisoning (symptoms include grogginess, lethargy, inappropriate tiredness, or flu-like symptoms).

1. The combustion air system installation must be in accordance with the current edition of the National Fuel Gas Code-NFPA 54 or ANSI Z223.1 National Fuel Gas Code. In Canada, installation must be in accordance with CSA-B149.1 "Installation Code for Natural Gas Burning Appliances and Equipment" and CSA-B149.2 "Installation Code for Propane Burning Appliances and Equipment."
2. Each unit heater MUST have its own combustion air system. It MUST NOT be connected to other air intake systems.
3. Use UL 1738 listed schedule 40 vent pipe for the vent system. For installations in Canada, use UL-S636 listed vent pipe conforming with local building codes, or in the absence of local building codes, with current CSA-B149.1 "Installation Codes for Natural Gas Burning Appliances and Equipment" or CSA-B149.2, "Installation Codes for Propane Gas Burning Appliances and Equipment."

▲ WARNING Do not use Type B (double wall) vent internally within the building on high efficiency unit heaters! This can result in death, serious injury or substantial property damage.

▲ WARNING Use of cellular core pipe for any exhaust vent component is prohibited. Use of cellular core pipe may result in severe personal injury, death, or major property damage.

NOTICE: Installations in Canada require compliance with ULC-S636 Standard for Type BH Gas Venting Systems.

4. Long runs of single wall combustion air piping passing through an unheated space may require insulating if condensation becomes noticeable.
5. Horizontally vented combustion air inlet piping shall be terminated with a 90 degree elbow or tee. Vertically vented combustion air inlet piping shall be terminated with a 180 degree elbow or two 90 degree elbows.
6. The combustion air inlet system must be installed to prevent collection of condensate. Pitch horizontal pipes downward 1/4 inch per foot (21 mm/m) toward the inlet cap to facilitate drainage.
7. The equivalent length of the combustion air system must not be less than 5 feet (1.5 m) and must not exceed 50 feet (15.2 m). Equivalent length equals the total length of straight pipe plus 5 feet (1.5 m) for each 90 degree elbow and 2.5 feet (0.76 m) for each 45 degree elbow.

NOTICE: For optimum performance keep the combustion air system as straight as possible.

8. A minimum vertical run of 12 inches (305 mm) is required between the unit's combustion air inlet connection and first elbow used.
9. Seal all vent pipe joints and seams to prevent leakage. All joints must be cleaned prior to assembly. Joints should then be primed in accordance with ASTM F 656. After priming, joints should be cemented per ASTM D 2564.
10. For horizontal combustion air systems longer than 5 feet (1.5 m), the system must be supported from overhead building structures at 4 foot (1.2 m) intervals in the U.S. and at 3 foot (0.91 m) intervals in Canada.

A field provided stainless steel screen may be placed on the inlet of the combustion air inlet pipe to prevent animals from entering the venting system.

EXHAUST VENTING

For flue pipe instruction, follow the steps in the STANDARD COMBUSTION VENTING sections.

Figure 10 - Vertical Two Pipe Separated Combustion Venting, Roof Termination

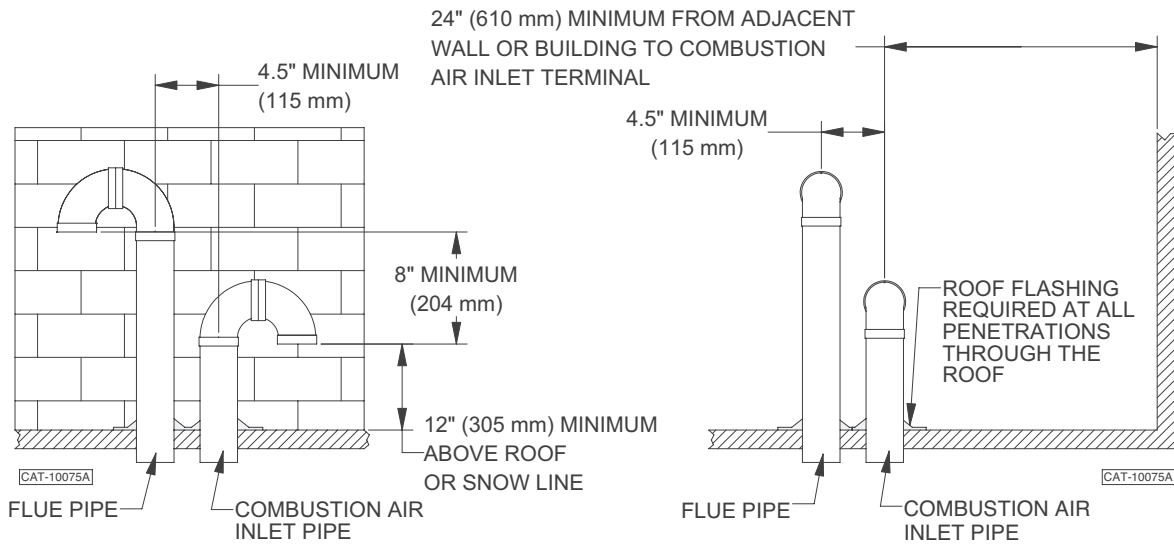

Figure 11 - Vertical Two Pipe Separated Combustion Venting, Sloped Roof Termination

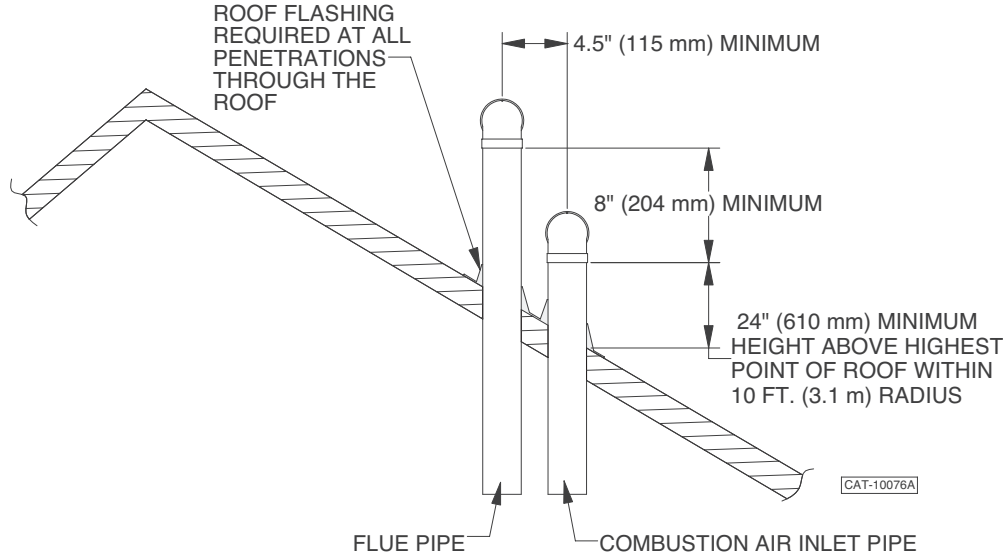
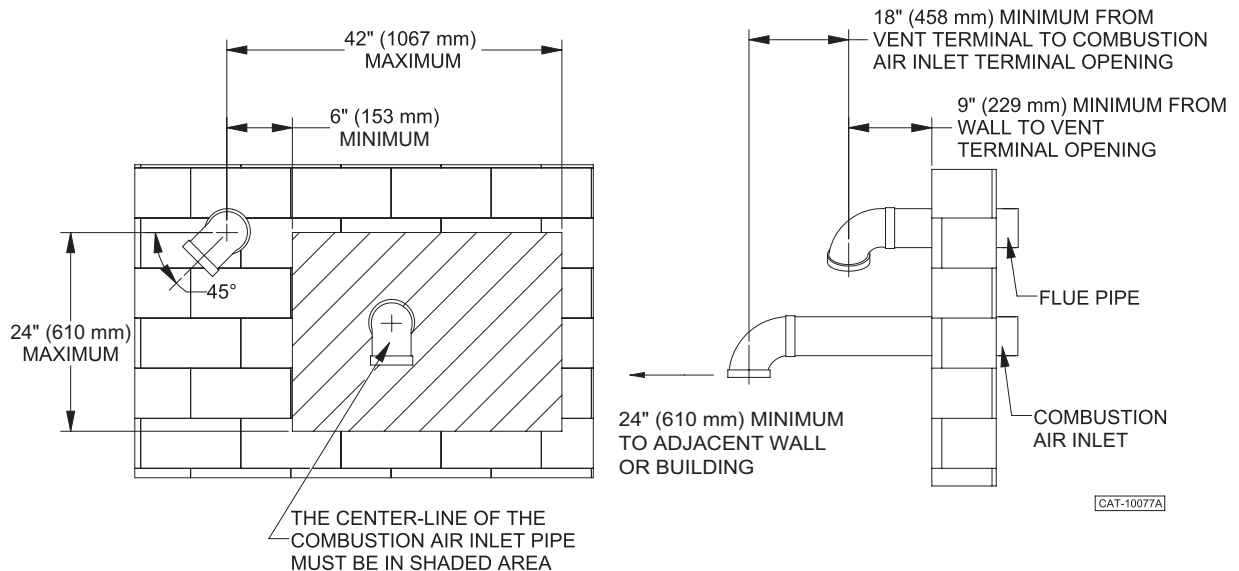

Figure 12 - Horizontal Two Pipe Separated Combustion Venting, Sidewall Termination



SEPARATED COMBUSTION – CONCENTRIC VENTING

NOTICE: Every Separated Combustion unit to be installed **MUST** use the factory-available Concentric Vent Kit. If you do not have this kit, contact the manufacturer **ASAP** to obtain one prior to installation.

AIR INLET COLLAR

When the unit is to be used in a separated vent system, the inlet collar located on the top panel of the unit will be connected to the combustion air intake pipe. This connection is made by using a field-provided rubber coupling in the appropriate size for each unit capacity. The coupling is installed so that air inlet pipe can be detached from the unit for serviceability purposes.

GENERAL

Concentric venting allows both the intake for combustion air and the exhaust vent to pass through a single standard roof or sidewall opening. This is an alternative to the standard two pipe intake/vent shown in the separated combustion venting instructions. Follow these instructions as well as the separated combustion venting instruction for installation of the intake/vent pipe(s) and all unit heater installation procedures.

IMPORTANT: Concentric venting reduces the allowable intake/vent piping length by 5 feet (1.5 m) from that listed in the venting instructions.

▲ WARNING Do not operate the unit until the installation and assembly of the Concentric Vent Kit and all piping are completed. Failure to follow this warning could result in fire, personal injury or death.

The Concentric Vent Kit contains the following parts:

- (1) Combustion Air Inlet Cap
- (1) Air Inlet Pipe
- (1) Vent Pipe
- (1) Intake/Vent Concentric “Y”

Figure 14 – Concentric Vent Kit Assembly

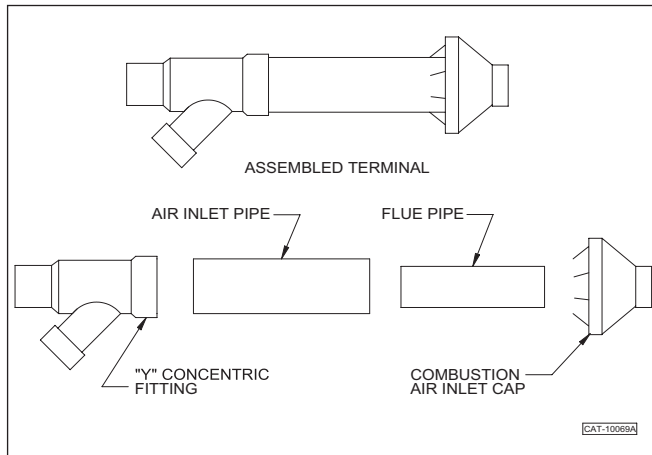

Pipe and fittings are required to complete installation (user supplied). The combustion air and vent pipe -fittings must conform to ANSI and ASTM standards D1785, F891, D2665, D2241, D2661, or F628. Pipe cement and primer must conform to ASTM standards D2564 or D2235.

In Canada, construct all combustion air and vent pipes for this unit of CSA or ULC certified Schedule 40 PVC, PVC-DWV, or ABS-DWV pipe and pipe cement.

Table 9 – Concentric Vent Kit Component Dimensions

Unit Size	Intake/Vent Nom. Pipe Size	Overall Assembled Length ¹	Intake Pipe Outside Diameter	Air Inlet Pipe Length ²
50-100	2"	34-3/4"	3-1/2"	19-1/2"
150	3"	39-1/8"	4-1/2"	24"
200-400	4"	57-1/4"	5-9/16"	41"

1. Shipping dimension. This may be field modified by cutting or extending both the intake and exhaust pipes. 12 inches (305 mm) is the minimum allowable length and 60 inches (1.5 m) is the maximum allowable length for this dimension. Only SDR-26 PVC (ASTM D2241) may be used for extending pipes. Do not extend pipes with Schedule 40 PVC or couplings.
2. This dimension will change if the intake/vent pipes are lengthened or shortened.

NOTICE: Some local code inspectors are not familiar with concentric vents. Be sure to check local code requirements and acceptability prior to installation.

HORIZONTAL SIDEWALL MOUNTING

NOTE: Refer to the following items before horizontal installation:

- Check INSTALLATION section of this manual for allowable clearances and locations.
- Refer to Figures 16 and 17 when venting multiple units using concentric venting.
- Avoid locations with high winds.
- Avoid locations where Concentric Vent Kit is likely to be damaged.
- Avoid locations where vapors are objectionable, or may damage the structure, plants or air conditioning condensing unit.

1. Determine correct concentric vent kit size for the unit capacity selected.
2. Determine the best location for the concentric vent; refer to Figures 15, 16, and 17. Also refer to Table 7 for vent termination clearance requirements.
3. When installing multiple units with concentric venting, refer to the following guidelines:
 - a. Do not install multiple concentric vent terminations directly above one another unless separated by a minimum of 3 feet (0.91 m); see Figure 16.
 - b. Install multiple concentric vent terminations so the horizontal distance between the ends of each air intake is 4 inches (102 mm) or less or greater than 24 inches (610 mm); see Figure 17. This will prevent a recirculation of flue gas.

SEPARATED COMBUSTION – CONCENTRIC VENTING (continued)

4. Cut a hole for Concentric Vent kit.
 - a. Cut a 4 inch (102 mm) diameter hole for size 50 - 100 unit, 2 inch (51 mm) concentric vent kit.
 - b. Cut a 5 inch (127 mm) diameter hole for size 150 unit, 3 inch (76 mm) concentric vent kit.
 - c. Cut a 6 inch (152 mm) diameter hole for size 200 - 400 unit, 4 inch (102 mm) concentric vent kit.
5. Partially assemble Concentric Vent Kit. Follow venting instructions for cleaning and cementing.
 - a. Cement “Y” fitting to larger diameter air inlet pipe (Figure 13).
 - b. Cement combustion air inlet cap to smaller diameter flue pipe (Figure 13).
6. Install “Y” fitting and pipe assembly through hole.
7. Install combustion air inlet cap and large diameter pipe assembly. Cement and fully insert small diameter pipe in “Y” concentric fitting.
8. Secure to structure using metal strapping or equivalent support material (field supplied); refer to Figure 14.
9. Cement combustion air and vent pipes to concentric vent kit. Refer to Figure 14 for proper pipe attachment.
10. Check installation by allowing unit to run through one cycle.

Figure 14 - Horizontal Concentric Vent Kit Installation

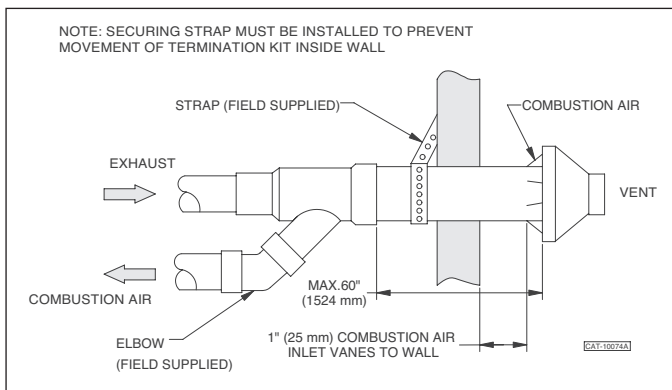

Figure 15 - Horizontal Sidewall Concentric Venting, Single Termination

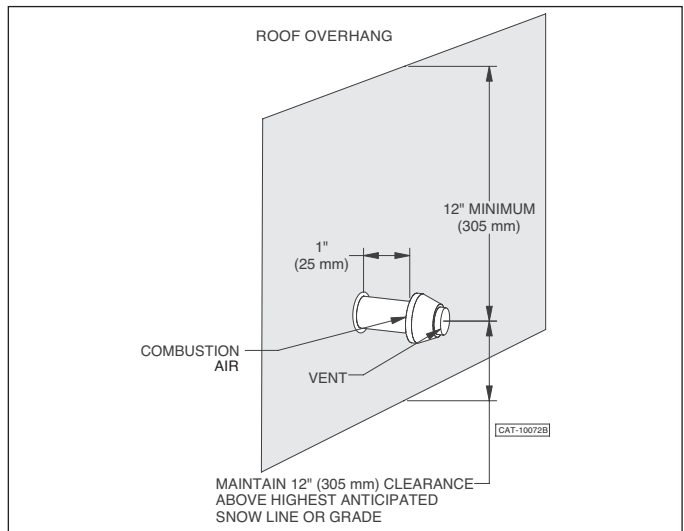

Figure 16 - Horizontal Sidewall Concentric Venting, Multiple Unit Vertical Layout

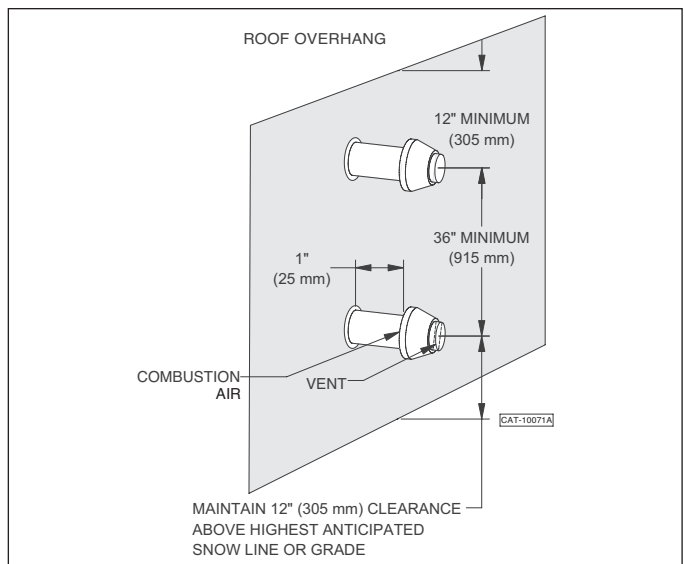
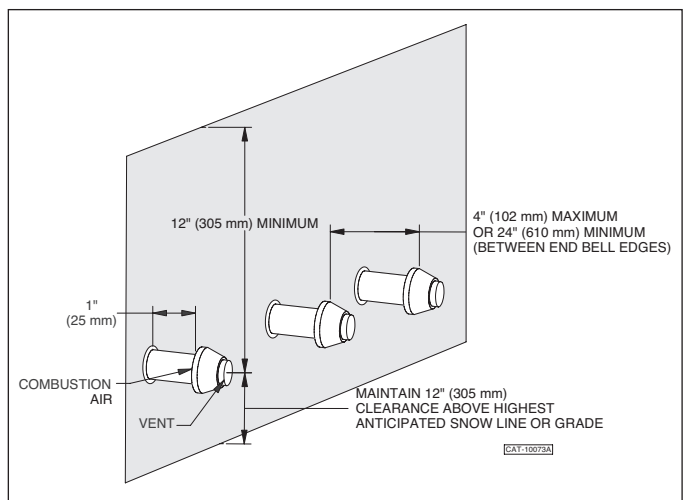

Figure 17 - Horizontal Sidewall Concentric Venting, Multiple Unit Horizontal Layout



SEPARATED COMBUSTION – CONCENTRIC VENTING (continued)

NOTE: Keep assembly free of insulation during installation.

NOTE: Maintain clearance dimensions as shown in Figures 15, 16, and 17. Also refer to Table 7 for vent termination clearance requirements.

NOTE: If assembly is too short, the two pipes supplied in the kit may be replaced by using same diameter, field supplied SDR-26 PVC (ASTM D2241) pipe. Do not extend pipes with Schedule 40 PVC or couplings. The additional wall thickness will restrict combustion air and may cause operational problems. Do not extend air inlet pipe more than 60 inches (1.5 m); see Figure 14.

▲ CAUTION Do not use field supplied couplings to extend pipes; flue gas may leak from the venting system resulting in unsafe conditions.

▲ WARNING If the venting system is not installed according to these guidelines, flue gas may recirculate, possibly causing the intake pipe to freeze shut during cold weather operation.

VERTICAL ROOF MOUNTING

NOTE: Roof mounting is recommended as it allows less intake air contaminants and reduces ground-level exhaust.

- Determine correct concentric vent kit size for the unit capacity selected.
- Determine the best location for the concentric vent.
- Cut a hole for Concentric Vent kit.
 - Cut a 4 inch (102 mm) diameter hole for size 50-100 unit, 2 inch (51 mm) concentric vent kit.
 - Cut a 5 inch (127 mm) diameter hole for size 150 unit, 3 inch (76 mm) concentric vent kit.
 - Cut a 6 inch (152 mm) diameter hole for size 200 - 400 unit, 4 inch (102 mm) concentric vent kit.
- Partially assemble Concentric Vent kit. Follow venting instructions for cleaning and cementing.
 - Cement “Y” fitting to larger diameter air inlet pipe (Figure 13).
 - Cement combustion air inlet cap to smaller diameter pipe (Figure 13).
- Install “Y” fitting and pipe assembly through hole and roof boot/flashing (field supplied).
- Secure to roof using metal strapping or equivalent support material (field supplied); refer to Figure 18.
- Install combustion air inlet cap and small diameter pipe assembly into roof. Cement and fully insert small diameter pipe in “Y” concentric fitting.
- Cement combustion air and vent pipes to concentric vent kit. Refer to Figure 14 for proper pipe attachment.
- Check installation by allowing unit to run through one cycle.

Figure 18 - Vertical Concentric Vent Kit Installation

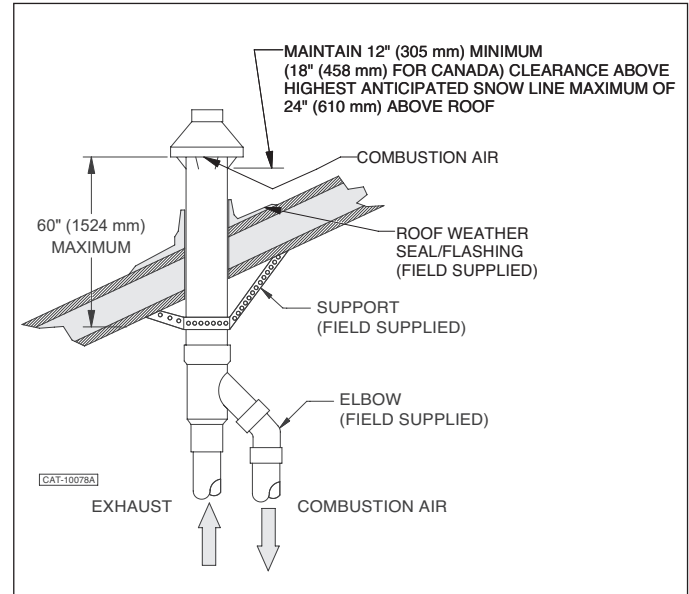
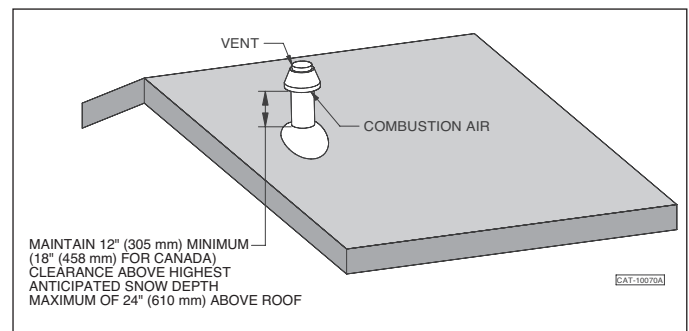

Figure 19 - Vertical Concentric Venting, Roof Termination



NOTE: Keep assembly free of insulation during installation.

NOTE: Install multiple concentric vent terminations so the horizontal distance between the ends of each air intake is 4 inches (102 mm) or less or greater than 24 inches (610 mm); see Figure 17. This will prevent a recirculation of flue gas.

NOTE: Termination height must be above roof surface or anticipated snow level (minimum 12 inches (305 mm) in U.S. or minimum 18 inches (458 mm) in Canada) as shown in Figures 18 and 19.

NOTE: If assembly is too short, the 2 pipes supplied in the kit may be replaced by using same diameter, field supplied SDR-26 PVC (ASTM D2241) pipe. Do not extend pipes with Schedule 40 PVC or couplings. The additional wall thickness will restrict combustion air and may cause operational problems. Do not extend air inlet pipe more than 60 inches (1.5 m); see Figure 14.

▲ CAUTION Do not use field supplied couplings to extend pipes; flue gas may leak from the venting system resulting in unsafe conditions.

OPERATION – HIGH EFFICIENCY GAS-FIRED PROPELLER UNITS

DIRECT SPARK IGNITION

EXPLANATION OF CONTROLS:

1. The unit heater is equipped with a power vent system that consists of a power venter motor and blower, pressure switches, and sealed flue collector.
2. The power venter motor is energized by the room thermostat through the integrated control boards when a demand for heat is sensed. The pressure switch measures the flow through the vent system and energizes the direct spark ignition system beginning the pre-purge timing when the flow is correct. During this 15 second pre-purge the pressure switch is made.

▲ WARNING The pressure switch **MUST NOT** be bypassed. The unit **MUST NOT** be fired unless the combustion blower and power venter are operating. An unsafe condition could result.

3. The direct spark ignition system consists of an ignition control module and a gas valve. When the pre-purge period ends, the spark ignition system is energized, and the gas valve opens to supply gas to the burners. The trial period for ignition will be 7 seconds.
 - a. If the unit fails to light in the trial period, the unit will immediately enter the post-purge period. Following the post-purge period, the unit will follow the same pre-purge period and try to light again. If the unit fails to light 3 times in a row, the unit will enter a soft lockout for up to 1 hour. If after 1 hour, the call for heat is still present, the unit will begin the ignition sequence again.

NOTE: Single stage units size 150 and larger are single stage gas control but use a 2-stage valve. The unit will light at low fire then go to high fire after 10 seconds.

4. Once the ignition is proved, propeller fan is enabled 30 seconds after gas valve opens.
5. The high limit switch interrupts the flow of electrical current to the ignition control and gas valve, interrupting the flow of gas to the gas burner if the unit heater becomes overheated.
6. For size 50 – 150 units, the rollout switch interrupts the flow of the electrical current to the ignition control and gas valve, interrupting the flow of gas to the gas burner if the temperature of the burner compartment exceeds rollout set point. If the rollout switch trips, the inducer and supply fans will continue to run until the rollout switch is manually reset.
7. The flue temperature limit interrupts the flow of electric current to the ignition control and gas valve, interrupting the flow of gas to the gas burner if the flue temperature exceeds flue temperature limit.

8. The float switch interrupts the flow of electric current to the ignition control and gas valve, interrupting the flow of gas to the gas burner if the condensate is unable to properly drain from unit.
9. Once the thermostat is satisfied, or the high limit or flue temperature limit interrupts the flow of electric current to the ignition control board, the unit will begin a 15 second post-purge period. When the post-purge period ends, the power venter motor is de-energized.
10. The fan operation is delayed 30 seconds once the thermostat is closed and continues operation for 90 seconds after the thermostat opens.

NOTICE: The start-up fan delay must not exceed 30 seconds from a cold start.

11. The wall thermostat, supplied optionally, is a temperature sensitive switch that operates the vent and ignition system to control the temperature of the space being heated. The thermostat must be mounted on a vertical, vibration-free surface free from air currents and in accordance with the furnished instructions (see also the ELECTRICAL CONNECTIONS section).

START-UP (Also refer to lighting instruction plate equipped on the unit)

1. Open the manual gas valve in the gas supply line to the unit heater. Loosen the union in the gas line to purge it of air. Tighten the union and check for leaks.

▲ WARNING Never use an open flame to detect gas leaks. Explosive conditions may exist which could result in personal injury or death.

2. Open the manual valve on the unit heater.
3. Turn ON the electrical power.
4. The unit should be under the control of the thermostat. Turn the thermostat to the highest set point and determine that the power venter motor starts, beginning pre-purge. After 15 seconds, the burners will ignite.

NOTE: Single stage units size 150 and larger are single stage gas control but use a 2-stage valve. The unit will light at low fire then go to high fire after 10 seconds.

5. Once in high fire, measure the supply gas pressure and record. Supply gas pressure should be 5.0 to 14.0" W.C. for natural gas, 11.0 to 14.0" W.C. for propane (LP) gas. See Gas Input Rate and Adjustment section to adjust manifold pressure.

OPERATION – HIGH EFFICIENCY GAS-FIRED PROPELLER UNITS DIRECT SPARK IGNITION (continued)

- | | |
|--|---|
| <p>6. Turn the thermostat to the lowest point and determine that the power venter motors shut off and the burners are extinguished.</p> <p>7. Turn the thermostat to the desired position.</p> | <p>SHUT DOWN</p> <ol style="list-style-type: none"> 1. Turn the valve selector lever to the “OFF” position. 2. Turn off the electricity. 3. To relight, follow START-UP instructions. |
|--|---|

Table 10 - CO₂ and O₂ Operating Ranges

Unit Size	Nat. gas		LP gas		NG/LP
	CO ₂ %	O ₂ %	CO ₂ %	O ₂ %	CO ppm
50	6.8 - 7.5	7.8 - 9.0	7.8 - 8.2	8.3 - 8.7	<50
100	6.8 - 7.5	7.8 - 9.0	8.3 - 8.6	7.8 - 8.1	<50
150	7.0 - 7.5	8.4 - 9.0	8.0 - 8.4	8.4 - 8.8	<50
200	6.8 - 7.5	7.8 - 9.0	8.3 - 8.7	7.7 - 8.1	<50
250	6.8 - 7.5	7.8 - 9.0	8.5 - 8.9	7.4 - 7.8	<50
300	7.0 - 7.5	8.4 - 9.0	7.9 - 8.4	8.3 - 8.8	<50
350	6.8 - 7.5	7.8 - 9.0	7.9 - 8.4	8.3 - 8.8	<50
400	7.0 - 7.5	8.4 - 9.0	8.7 - 9.1	7.1 - 7.7	<50

Note: Combustion readings are not required to start-up the equipment. However, they may be useful to confirm proper unit operation and troubleshooting. Combustion values are based on 70°F combustion air.

GAS INPUT RATE

Check the gas input rate as follows (Refer to GENERAL SAFETY INFORMATION section for metric conversions):

▲ CAUTION Never over-fire the unit heater, as this may cause unsatisfactory operation, or shorten the life of the heater.

1. Turn off all gas appliances that use gas through the same meter as the unit heater.
2. Turn the gas on to the unit heater.
3. Clock the time in seconds required to burn 1 cubic foot of gas by checking the gas meter.
4. Insert the time required to burn one cubic foot of gas into the following formula and compute the input rate.

$$\frac{3600 \text{ (Sec. per Hr.)} \times \text{BTU/Cu. Feet} = \text{Input Rate}}{\text{Time (Sec)}}$$

For example:

Assume the BTU content of one cubic foot of gas is 1000, and that it takes 18 seconds to burn one cubic foot of gas.

$$\frac{3600 \times 1000}{18} = 200,000$$

NOTICE: If the computation exceeds, or is less than 95% of the unit's gas BTU/hr. input rating, adjust the gas valve.

Adjust the gas pressure as follows:

1. NATURAL GAS: Best results are obtained when the unit heater is operating at its full rated input with the manifold pressure of 3.5 in. W.C. (0.9 kPa). Adjustment of the pressure regulator is not normally necessary since it is preset at the factory. However, field adjustment may be made as follows:
 - a. Attach manometer at the pressure tap plug adjacent to the control outlet.
 - b. Remove the regulator adjustment screw cap, located on the combination gas valve.
 - c. With a small screwdriver, rotate the adjustment screw counterclockwise to decrease pressure, or clockwise to increase pressure.
 - d. Replace regulator adjustment screw cap.
 - e. For units with two stage gas valves, to adjust low fire pressure setpoint:
 - i) Remove wire from "HI" terminal on gas valve.
 - ii) Adjust low fire per Table 5 Gas Piping Requirements
 - iii) Reconnect wire on "HI" terminal on gas valve.

2. PROPANE GAS: A high fire manifold pressure of 10.0 in. W.C. (2.5 kPa) must be maintained for proper operation of the unit heater. Follow steps "a" through "e" above for valve adjustment. Note: For Propane high fire should be set to 10.0 in. W.C. (2.5 kPa) and low fire should be adjusted per Table 5 Gas Piping Requirements.
3. The adjusted manifold pressure should not vary more than 10% from pressure specified in Table 11.

Table 11 - Main Burner Orifice Schedule*

* INPUT IN 1000 BTU	TYPE OF GAS	NATURAL	PROPANE	NO. OF BURNER ORIFICES
	HEATING VALUE	1050 BTU/Ft ³ (39.1MJ/M ³)	2500 BTU/Ft ³ (93.1MJ/M ³)	
	MANIFOLD PRESSURE	3.5" W.C. (0.87 kPa)	10" W.C. (2.49 kPa)	
50	FT ³ /HR	48	20	2
	ORIFICE DRILL	42	54	
100	FT ³ /HR	95	40	3
	ORIFICE DRILL	37	52	
150	FT ³ /HR	143	60	4
	ORIFICE DRILL	32	50	
200	FT ³ /HR	190	80	5
	ORIFICE DRILL	31	49	
250	FT ³ /HR	238	100	6
	ORIFICE DRILL	32	49	
300	FT ³ /HR	286	120	7
	ORIFICE DRILL	31	49	
350	FT ³ /HR	333	140	8
	ORIFICE DRILL	31	49	
400	FT ³ /HR	381	160	9
	ORIFICE DRILL	31	49	

*This schedule is for units operating at normal altitudes of 2000 ft. (610m) or less.

When installed in Canada, any references to deration at altitudes in excess of 2000 ft. (610m) are to be ignored. At altitudes of 2000 to 4500 ft. (610 to 1372m), the unit heaters must be field derated to 90% of the normal altitude rating, and be so marked in accordance with ETL certification. See Table 11A for field deration information.

HIGH ALTITUDE DERATION

This unit heater has been manufactured utilizing standard burner orifices and gas pressure setting as per the specifications shown on the unit rating plate.

adjustment label to the unit, and record adjusted manifold pressure, altitude of the unit installation and the technician's name and date on the label using a permanent marker.

All unit deration must be done through field adjustments by a qualified technician. Once the proper adjustments are made in the field, attach high altitude

Refer to Gas Input Rate section for adjusting the manifold pressure.

Table 11A

High Altitude Deration - United States						
Altitude		Manifold Pressure				BTU Output ¹
		Natural Gas ²		Liquid Propane ³		
Feet	Meters	Inches W.C.	Pa	Inches W.C.	Pa	Percentage
0-2,000	0-610	3.5	871	10	2,488	100%
2,001-3,000	611-915	3.0	747	8.5	2,115	92%
3,001-4,000	916-1,220	2.7	672	7.7	1,916	88%
4,001-5,000	1,221-1,525	2.5	622	7.1	1,767	84%
5,001-6,000	1,526-1,830	2.2	547	6.4	1,593	80%
6,001-7,000	1,831-2,135	2.0	498	5.8	1,443	76%
7,001-8,000	2,136-2,440	1.8	448	5.2	1,294	72%
8,001-9,000	2,441-2,745	1.6	398	4.6	1,145	68%
9,001-10,000	2,746-3,045	1.4	348	4.1	1,020	64%

Notes:

1. Deration based on ANSI Z223.1 (NFPA 54).
2. Table based on heating value of 1,050 BTU/Cu. ft. at sea level.
3. Table based on heating value of 2,500 BTU/Cu. ft. at sea level.
4. Consult local utility for actual heating value

High Altitude Deration - Canada						
Altitude		Manifold Pressure				BTU Output ¹
		Natural Gas ²		Liquid Propane ³		
Feet	Meters	Inches W.C.	Pa	Inches W.C.	Pa	Percentage
0-2,000	0-610	3.5	871	10	2,488	100%
2,001-3,000	611-915	3.2	796	9.2	2,289	96%
3,001-4,000	916-1,220	2.9	722	8.4	2,090	92%
4,001-4,500	1,221-1,371	2.8	697	7.9	1,966	90%

Notes:

1. Deration based on CGA 2.17-M91
2. Table based on heating value of 1,050 BTU/Cu. ft. at sea level.
3. Table based on heating value of 2,500 BTU/Cu. ft. at sea level.
4. Consult local utility for actual heating value

INDUCER SPEED BOARD CONFIGURATION

The Inducer Speed Board is configured for each unit size by setting the dip switches to the corresponding configuration. See Figure 20.

Figure 20 - Inducer Speed Control Board, Dip Switch Configuration by Unit Size

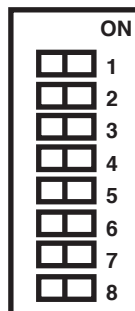

Size	Dip Switch Number							
	1	2	3	4	5	6	7	8
50	ON	OFF	OFF	OFF	OFF	OFF	OFF	OFF
100	OFF	ON	OFF	OFF	OFF	OFF	OFF	OFF
150	OFF	OFF	ON	OFF	OFF	OFF	OFF	OFF
200	OFF	OFF	OFF	ON	OFF	OFF	OFF	OFF
250	OFF	OFF	OFF	OFF	ON	OFF	OFF	OFF
300	OFF	OFF	OFF	OFF	OFF	ON	OFF	OFF
350	OFF	OFF	OFF	OFF	OFF	OFF	ON	OFF
400	OFF	OFF	OFF	OFF	OFF	OFF	OFF	ON

HIGH EFFICIENCY GAS-FIRED UNIT HEATER TROUBLESHOOTING GUIDE

SYMPTOMS	POSSIBLE CAUSE(S)	CORRECTIVE ACTION
1. Flame pops back.	1. Burner orifice too small.	1. Refer to GAS INPUT RATE, Main Burner Orifice Schedule. Check with local gas supplier for proper orifice size and replace.
2. Noisy flame	1. Irregular orifice causing whistling or resonance. 2. Excessive gas input.	1. Replace orifice. 2. Test and adjust manifold pressure.
3. Yellow tip flame (some yellow tipping on LP gas is permissible).	1. Clogged main burners. 2. Misaligned orifices. 3. Insufficient combustion air. 4. Possibly over fired.	1. Clean main burner ports. 2. Replace or adjust manifold assembly. 3. Refer to installation clearances and venting sections to ensure unit is properly mounted and vented. 4. Check gas input and manifold pressure. If possible, check combustion (CO ₂ & CO).
4. Floating flame.	1. Blocked venting. 2. Insufficient combustion air. 3. Blocked heat exchanger 4. Air leak into combustion chamber or inducer failure/leak.	1. Clean Flue. Refer to INSTALLATION section. 2. Clean combustion air inlet openings. 3. Clean heat exchanger. Refer to INSTALLATION. 4. Determine cause and repair accordingly.
5. Gas odor.	1. Shut off gas supply immediately! 2. Leaking port on valve. 3. Blocked heat exchanger. 4. Blocked flue collector. 5. Negative pressure in the building.	1. Inspect all gas piping and repair. 2. Check to ensure valve ports are seated. 3. Clean heat exchanger/flue. 4. Clean flue collector. 5. See INSTALLATION.
6. Delayed ignition.	1. Improper ground. 2. Bad or broken spark cable. 3. Faulty control. 4. Pressure regulator set too low. 5. Main burner and/or orifice dirty. 6. Improper venting.	1. Check grounding wires and spark bracket connections. 2. Inspect spark cable connections and cuts. 3. Check to ensure spark is energized after pre-purge period. 4. Test and reset manifold pressure refer to GAS INPUT RATE section. 5. Clean orifice or burners. 6. Refer to INSTALLATION section.
7. Failure to ignite.	1. Gas supply is off. 2. No power supply to unit. 3. Thermostat not calling. 4. Defective high limit or flue limit. 5. Defective drafter prove switch. 6. Loose wiring. 7. Improper ground. 8. Improper thermostat or transformer wiring. 9. Condensate trap clogged or leaking. 10. Defective ignition control. 11. Inducer speed board dip switches incorrectly set.	1. Open all manual valves "check for leaks". 2. Turn on power supply, check fuses and replace if bad. 3. Turn up thermostat, Check for 24V on terminals R and W1 on terminal strip. 4. Check switches for continuity if open with no heat present, replace. 5. Check switch operation to ensure switch closes after drafter purge period. If it does not make/check tubing connections/ blockage. 6. Check all wiring per diagram. 7. Check all ground wires and connections. 8. Check both, for wiring according to diagram; check for 24V at gas valve terminals during trial for ignition period if present and valve does not open. Replace valve. 9. Clean condensate trap. 10. Replace ignition control. 11. See INDUCER SPEED BOARD CONFIGURATION and correct setting.
8. Burners will not shut off.	1. Thermostat located incorrectly. 2. Improper thermostat wiring 3. Shorted circuit. 4. Defective sticking gas valve. 5. Excessive gas supply pressure. 6. Defective thermostat 7. Defective ignition control board	1. Relocate thermostat away from outside wall or drafts. 2. Check thermostat circuit for open and close on terminal strip on heater "R" and "W". 3. Check thermostat circuit for shorts, staples piercing wires. 4. Check for 24V on gas valve terminals when thermostat is not calling. 5. Refer to INSTALLATION. 6. If thermostat is calling after set point has been satisfied, replace. 7. Check for 24V at terminals "R" and "W". If not present and board is not in flash code mode, replace board.
9. Rapid burner cycling.	1. Loose electrical connections at thermostat or gas valve. 2. Excessive thermostat heat anticipator or deadband setting. 3. Unit cycling on high limit. 4. Unit cycling on flue limit. 5. Poor thermostat location. 6. An improper ground.	1. Tighten all electrical connections. 2. Adjust heat anticipator or deadband setting for longer cycles. Refer to ELECTRICAL CONNECTIONS. 3. Check for proper air supply across heat exchanger and proper gas supply. 4. Check for correct vent and proper gas supply. 5. Relocate thermostat. 6. Check ground wiring.
10. Noisy power venter.	1. Power venter wheel loose. 2. Power venter wheel is dirty. 3. Power venter wheel is rubbing on the housing.	1. Replace or tighten. 2. Clean power venter wheel. 3. Realign power venter wheel.

SYMPTOMS	POSSIBLE CAUSE(S)	CORRECTIVE ACTION
11. Fan will not run.	<ol style="list-style-type: none"> Loose electrical connections. Defective motor or overload. Defective ignition control board. Defective fan relay. 	<ol style="list-style-type: none"> Check and tighten wires on fan circuit. Test for 115V on terminal ACC1 and "L2" if voltage is present replace motor. Test for 115V on terminal ACC1 and "L2" on the control board; if voltage is not present 45 seconds after trial for ignition, replace board. Check for 24 volts on terminals 24 and 0. Check for 115V on normally open relay contact when calling.
12. Fan motor turns on and off while burner is operating.	<ol style="list-style-type: none"> Motor overload protection is tripping. Loose wiring or connection. Ignition control board is defective. 	<ol style="list-style-type: none"> Check motor amps against motor name plate, check voltage, replace if found defective. Check for 115V between motor leads. Check terminal ACC1 for 115 volts. If voltage is not constant, replace control board.
13. Fan will not stop.	<ol style="list-style-type: none"> Ignition control board is in flame failure mode. Fan improperly wired. Defective board. Defective fan relay or contactor. High limit or flue limit tripped. 	<ol style="list-style-type: none"> Turn 115V power off to the unit, wait 10 seconds and reapply voltage to the unit. Check wiring of fan circuit to wiring diagram. If unit is not calling for heat and board is not in a flash code mode, replace board. Check for 0 volts on terminals "115" for relay or "T1" for contactor and Ground. Check for 0 on normally open relay contact when calling. See High Limit and Flue Limit Tripping in troubleshooting section.
14. Not enough heat.	<ol style="list-style-type: none"> Incorrect gas input. Heater undersized. Thermostat malfunction. Heater cycling on limit. Incorrect orifice size. Defective time delay relay (size 150-400 only). 	<ol style="list-style-type: none"> Refer to OPERATION. Is the heater output sized correctly for heat loss of the space. Has the space been enlarged. Check thermostat circuit, 24V on terminals "R" and "W" on terminal strip. Check air movement across heat exchanger. Check voltage and amps at the fan motor. Check gas input to ensure unit is not over fired. Check heat exchanger to ensure unit is not dirty. Check orifice size, replace if undersized. Check 24V on terminals "3" and "4" on time delay relay.
15. Too much heat.	<ol style="list-style-type: none"> Unit is over fired. Thermostat malfunction. Heater runs continuously. 	<ol style="list-style-type: none"> Refer to OPERATION. Check orifice size. If too big replace. Check thermostat for operation, to ensure circuit open and closes. Check wiring per diagram; check operation at the gas valve, look for a short in thermostat circuit.
16. Cold air is delivered during heater operation.	<ol style="list-style-type: none"> Incorrect gas input. Air throughput too high. 	<ol style="list-style-type: none"> Refer to OPERATION. Refer to OPERATION.
17. High limit tripping.	<ol style="list-style-type: none"> Unit is over fired. Airflow is low. Defective switch. Defective ignition control board. 	<ol style="list-style-type: none"> Burner orifices may be too large, verify and replace. Check for proper clearance, voltage, ensure fan blade is correct and free of debris. Check high limit switch with unit off. If open, replace switch. Check for 24V on line side of the high limit. Constant voltage should be recorded. If not, control board is suspect. Check flash code.
18. Power venter will not run.	<ol style="list-style-type: none"> Loose wiring or connections. Motor overload is tripped or bad motor. Failed ignition control board. Failed inducer speed board or incorrect dip switch settings. 	<ol style="list-style-type: none"> Check all wiring in the power vent circuit to ensure good connection, including "Neutral". Check for 115V between motor leads and check amp draw of motor. Replace if needed. Check for continuous 115V on terminal "CBM Blower" and neutral during call for heat. If not present and all checks are normal, replace. See Inducer Speed Board Flash Code table.
19. Power venter turns on and off during operation.	<ol style="list-style-type: none"> Power venter improperly wired. Motor overload cycling or defective motor. Defective ignition control board. Failed inducer speed board or incorrect dip switch settings. 	<ol style="list-style-type: none"> Check power venter circuit per wiring diagram. Check motor voltage and amp draw to motor name plate, replace if motor found defective. Check for continuous 115V on terminal "CBM Blower" during call for heat, replace board if found defective. See Inducer Speed Board Flash Code table.
20. Power venter will not stop.	<ol style="list-style-type: none"> Power venter improperly wired. Main burner did not light on call for heat. Defective ignition control board. Failed inducer speed board or incorrect dip switch settings. 	<ol style="list-style-type: none"> Check power venter circuit per wiring diagram. Heater is in lockout mode check flash code table for problem. No flash codes present along with no call for heat, replace control board. See Inducer Speed Board Flash Code table.
21. Flue temperature switch tripping.	<ol style="list-style-type: none"> Unit over fired. Blocked heat exchanger Blocked combustion air or flue vent pipe. Clogged heat exchanger coil fins. Failed ignition control board. 	<ol style="list-style-type: none"> Refer to operation section. Clean heat exchanger/flue collector. Clean combustion air or flue vent pipe. Clean heat exchanger coil fins. Check for 24V on line side of the high limit. Constant voltage should be recorded. If not, control board is suspect. Check flash code.

HIGH EFFICIENCY GAS-FIRED UNIT HEATER TROUBLESHOOTING WITH LED INDICATOR ASSISTANCE

No Cycling or appliance power or thermostat call for heat since appliance failure has occurred.

▲ WARNING Line voltage power can cause product damage, severe injury or death. Only a trained experienced service technician should perform this troubleshooting.

1. Check the system thermostat to make sure it is calling for heat. (Do not cycle the thermostat on and off at this time.)
2. Do not interrupt power to the control boards by opening any electrically interlocked panels.
3. Observe the LED indicator on the access panel side (a green LED indicates system faults); check and repair system as noted in the chart below.

NOTICE: Pressure switch and power venter hose barbs must be free of any dust or debris at all times. Periodically check these openings and/or if any problems occur.

Table 12 - Main Ignition Board Flash Codes

LED STATUS	INDICATES	CHECK/REPAIR
Slow Flash	Control OK, no call for heat.	Not Applicable
Fast Flash	Control OK, call for heat present.	Not Applicable
Steady Off	Internal control fault, or no power.	<ol style="list-style-type: none"> 1. Line voltage on terminals 120 and C on transformer. 2. Low voltage (24V) on terminals 24 and C on transformer. 3. 5 Amp fuse on circuit board.
Steady On	Control internal failure or bad ground.	<ol style="list-style-type: none"> 1. Common side of transformer grounded to chassis. 2. Loose spark ignitor.
2 Flashes	In lockout from failed ignitions or flame losses.	<ol style="list-style-type: none"> 1. Gas supply off or gas supply pressure too low. 2. Flame sense rod contaminated or loose wire. 3. Gas valve switch is off or wires are not connected. 4. Broken or cracked porcelain on flame probe or spark ignitor.
3 Flashes	Pressure Switch is open with inducer on or closed with inducer off.	<ol style="list-style-type: none"> 1. Obstructions or restrictions in appliance air intake or flue outlet are preventing proper combustion airflow. 2. Moisture or debris in tubing that connects pressure switch and draft inducer. 3. Pressure switch jumpered or miswired.
	Float switch is open.	<ol style="list-style-type: none"> 1. Obstruction or restriction in condensate system. 2. Float switch is miswired or stuck open. 3. If applicable, condensate pump miswired or failed.
4 Flashes	Limit or rollout switch is open.	<ol style="list-style-type: none"> 1. Open manual reset rollout switch. 2. Gas pressure too high, over fire condition. 3. Incorrect airflow due to blockage or motor not operating.
5 Flashes	Flame sensed while gas valve is off.	<ol style="list-style-type: none"> 1. Flame probe miswired or shortened.
6 Flashes	On-board microprocessors disagree.	<ol style="list-style-type: none"> 1. Thermostat is interfering with ignition control board.

Table 13 - Inducer Speed Control Board Flash Codes

LED STATUS	INDICATES	CHECK/REPAIR
Off	No Warning	No warning or issue present
2 Red Flashes	No TAC is being received from main control board (auto reset)	<ol style="list-style-type: none"> 1. Check wiring for loose or broken connection between main ignition board and inducer speed control board. 2. Confirm 24volt present on J1 connector on inducer speed board. 3. Confirm 115volt present on J2 inducer speed board.

MAINTENANCE

PERIODIC SERVICE

NOTICE: The heater and vent system should be checked once a year by a qualified technician.

All Maintenance/Service information should be recorded accordingly on the GAS EQUIPMENT START-UP AND INSPECTION SHEET provided in this manual.

▲ WARNING Open all disconnect switches, disconnect all electrical and gas supplies, and secure in that position before servicing unit. Failure to do so may result in personal injury or death from electrical shock.

▲ WARNING Gas tightness of the safety shut-off valves must be checked on at least an annual basis. Failure to do so may result in death, serious injury or substantial property damage.

To check gas tightness of the safety shut-off valves:

1. Turn off the manual valve upstream of the appliance combination control.
2. Remove the 1/8 in. pipe plug on the inlet side of the combination control and connect a manometer to that tapping.
3. Turn the manual valve on to apply pressure to the combination control.
4. Note the pressure reading on the manometer, then turn the valve off.
5. A loss of pressure indicates a leak. If a leak is detected, use a soap solution to check all threaded connections.
6. If no leak is found, combination control is faulty and must be replaced before putting appliance back in service.

Should maintenance be required, perform the following inspection and service routine:

1. Inspect the area near the unit to be sure that there is no combustible material located within the minimum clearance requirements listed in this manual.

▲ WARNING Under no circumstances should combustible material be located within the clearances specified in this manual. Failure to provide proper clearance could result in personal injury or equipment damage from fire.

2. Turn off the manual gas valve and electrical power to the unit heater.

3. To clean or replace the burners, remove burner side access panel. Disconnect field supplied union before unit gas connection. Remove screws holding manifold in place and rotate out of the way. Remove screws holding burner in place. Lift burner assembly up and pull away from heat exchanger to remove.
4. With burner removed, wire brush the inside surface of the heat exchanger.
5. Remove any dirt, dust, or other foreign matter from the burners using a wire brush and/or compressed air.
6. Inspect air inlet for blockage/debris. Clear if any found.
7. Reassemble the unit heater by replacing all parts in reverse order.
8. Check the burner adjustment.
9. Check all gas control valves and pipe connections for leaks.

▲ WARNING Check all pipe joints for leakage using a soap solution or other approved method. Never use an open flame or severe personal injury or death may occur!

10. Check the operation of the automatic gas valve by lowering the setting of the thermostat, stopping the operation of the gas duct furnace. The gas valve should close tightly, completely extinguishing the flame on the burners.
11. Inspect and service motor/fan assembly. To maintain efficient air flow, inspect and clean the fan blades and guard to prevent buildup of foreign matter.
12. Check motor lubrication. If oiling is required, add 1 or 2 drops of electric motor oil as follows:
 - a. Light Duty - After 3 years or 25,000 hours of operation.
 - b. Average Duty - Annually after 3 years or 8,000 hours of operation.
 - c. Heavy Duty - Annually after 1 year or at least 1500 hours of operation.

▲ CAUTION Never over oil the motor or premature failure may occur! Over oiling the motor may result in minor injury or property damage.

13. The condensate trap can be cleaned by loosening the connector tabs. The float should be cleaned of any debris.
14. Check and test the operational functions of all safety devices supplied with unit.

LIMITED WARRANTY MODEL XH/BXH UNIT HEATERS

The Manufacturer warrants to the original owner (hereinafter "Owner"), or entity designated by Owner to file claim on Owner's behalf, e.g. distributor, installation contractor, end-user ("Owner Designate") at the original installation site ("Site") that the components that comprise the MODEL XH/BXH UNIT HEATERS ("Products") will be free from defects in material and workmanship for the periods set forth below.

The Manufacturer warrants to the Owner or Owner Designate that the parts comprising the Products will be free from defects in material and workmanship for eighteen (18) months from the date of shipment from the factory or one (1) year from the date of unit startup, whichever occurs first, except where noted otherwise herein.

The Manufacturer further warrants to the Owner or Owner Designate that the Heat Exchanger, flue collector, and burners provided in the Product will be free from defects in material and workmanship for a period of ten (10) years (non prorated) from the date of shipment from the factory.

The Manufacturer further warrants to the Owner or Owner Designate that the Exterior Jacketry provided on the Product will be free from defects in material and workmanship for a period of five (5) years (non prorated) from the date of shipment from the factory.

All warranty claims are subject to, and contingent upon, Owner or Owner Designate following the terms of the Warranty claim service procedure and additional conditions set forth below and failure to follow the Warranty claim service procedure will void the warranty.

Warranty claim service procedure:

1. Owner should perform the following in order to insure prompt warranty service:
 - a. Notify the installer, who in turn should notify the distributor, promptly upon discovery of a condition believed to be caused by a defect in manufacture.
 - b. Owner must first obtain a Return Material Authorization ("RMA") and shipping instructions from the Manufacturer before returning any Products or components thereof.
 - c. Products or components thereof must be returned to the Manufacturer's factory address set forth when obtaining the RMA, fully prepaid at sender's expense, and risk of loss or damage, including packaging, transportation and any applicable VAT and import duty costs, Warranty excludes all Expenses associated with the prepaid return of Products to Manufacturer and remain the responsibility of the sender. Collect shipments will be refused.
 - d. Manufacturer shall evaluate the returned Products or components thereof purported to be defective due to defects in material or Manufacturer's workmanship and will determine in its reasonable and sole discretion if indeed such defects have occurred.
 - e. If indeed the Product or portion thereof is determined to be defective due to defects in material or Manufacturer's workmanship, Manufacturer shall either repair or replace, at its option, the portion of the Product deemed defective. Any warranty credits will be subject to verification of a defect by the manufacturer and any returned Products or components thereof shall become the property of the Manufacturer.
 - f. Repaired or replacement Products or components thereof shall be returned to Owner on a pre-paid basis with reasonable standard freight and transit insurance covered by Manufacturer. The repair or replacement of a Product shall not extend the effective period of the original warranty on the Product.

Additional Conditions:

- g. All Products are inspected prior to shipment from factory. If Products or components thereof received are damaged, claims must be made to the delivering carrier, and such damages should be noted on the bill of lading. Claims for shortages must be noted on the bill of lading and the factory notified immediately.
- h. Returned Products or components thereof will be subject to a minimum of 25% restock/handling charge if Manufacturer's evaluation determines Products or components returned are not defective due to defects in material or Manufacturer's workmanship.

LIMITED WARRANTY (continued)

MODEL XH/BXH UNIT HEATERS

EXCLUSIONS TO WARRANTY COVERAGE (all exclusions will be determined in the sole discretion of Manufacturer):

1. On-site labor or services including but not limited to those of those of the Manufacturer or any expenses for removal of Products for evaluation or reinstallation of replacement Products all of which are the responsibility of Owner.
2. Any damage caused by fire or other casualties; flooding from hurricanes or otherwise exposure to the elements; settlement, distortion, collapse or cracking of any foundation area, beams or pipes surrounding the Product.
3. Damage due to corrosion by chemicals, including halogenated hydrocarbons, precipitated in the air.
4. Damage associated with or caused by the installation of the Products regardless of whether the installer, provided by the Owner, is considered, or was authorized by Manufacturer, to be a qualified contractor, to perform the installation. The installation contractor is solely and exclusively responsible for its own work and the results thereof.
5. Damage or loss occurring during shipment. Warranty excludes all Expenses associated with the prepaid return of Products to Manufacturer and are the responsibility of the sender.
6. Damage, whether unintentional or not, from misuse or neglect.
7. Products that were not properly installed, maintained (serviced annually) or operated by a qualified contractor in accordance with the Manufacturer's furnished written instructions, and meets the good practice as defined by the industry's accepted authority, or were altered or modified in anyway by any person other than those authorized in writing by the Manufacturer to do so.
8. Auxiliary Products or components thereof furnished by the Manufacturer but manufactured by another party, ("Third Party Items") which may be incorporated in the Products shall bear no warranties other than the warranties extended by and enforceable against the original manufacturer of the Third Party Items at the time of shipment to Owner). Other parts or any other components of the Products not specifically listed herein.

THIS WARRANTY IS THE EXCLUSIVE WARRANTY APPLICABLE TO THE MODEL XH/BXH UNIT HEATER PRODUCT(S) HEREIN AND IS IN LIEU OF ALL OTHER WARRANTIES, EXPRESS OR IMPLIED, OF ANY KIND AND SUPERSEDES ALL OTHER WARRANTIES, INCLUDING THOSE CONTAINED IN OTHER DOCUMENTS WHICH MIGHT HAVE BEEN INCLUDED WITH THE PRODUCTS AT THE TIME OF SHIPMENT. THE REMEDIES UNDER THIS WARRANTY ARE EXCLUSIVE TO THE ORIGINAL OWNER ("OWNER") AT THE ORIGINAL PLACE OF INSTALLATION AND MANUFACTURER NEITHER ASSUMES NOR AUTHORIZES ANYONE TO OFFER OR ASSUME FOR IT ANY OTHER OBLIGATIONS. IN NO EVENT SHALL MANUFACTURER, INC. BE LIABLE FOR ANY DIRECT DAMAGES THAT EXCEED THE SALE PRICE OF THE PRODUCT(S) OR SECTIONS OR COMPONENTS THEREOF FOUND BY THE MANUFACTURER TO BE DEFECTIVE, OR ANY SPECIAL, INDIRECT, CONSEQUENTIAL, PUNITIVE OR INCIDENTAL DAMAGES OF ANY KIND, OR ON-SITE LABOR, EXPENSES OF ANY KIND, LOST PROFITS, LOST OPPORTUNITIES, OR SIMILAR DAMAGES OF ANY KIND; AND REGARDLESS OF THE LEGAL THEORY OR CAUSES OF ACTION BY WHICH CLAIMS FOR ANY SUCH DAMAGES AS SET FORTH IN THE ENTIRETY OF THE DOCUMENTS RELATED TO THE SALE OF THE PRODUCTS ARE ADVANCED, WHETHER OR NOT MANUFACTURER HAS BEEN ADVISED OF THE POSSIBILITY OF ANY SUCH DAMAGES.

In the interest of product improvement, we reserve the right to make changes without notice.

IDENTIFICATION OF PARTS

Figure 21 - Heat Exchanger

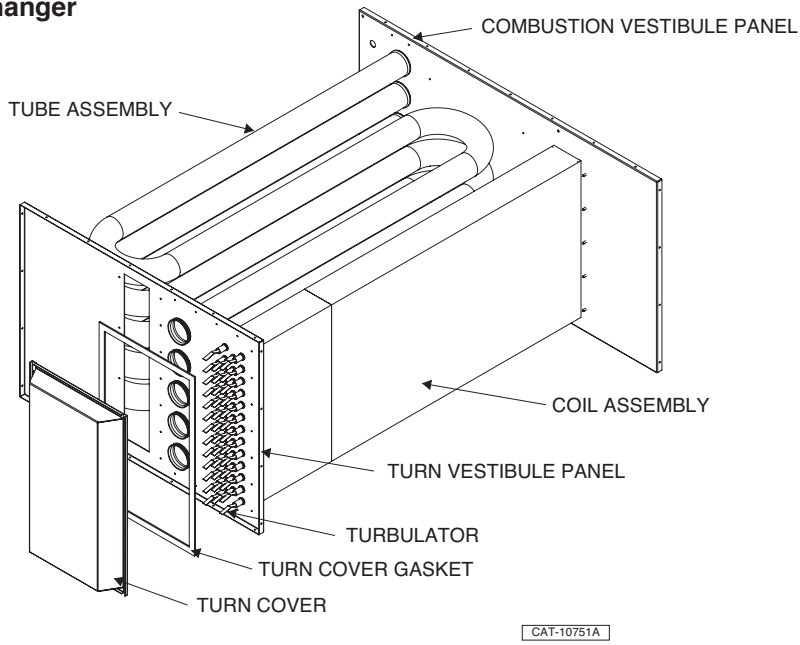

Figure 22 - Propeller Motor/Fan Assembly

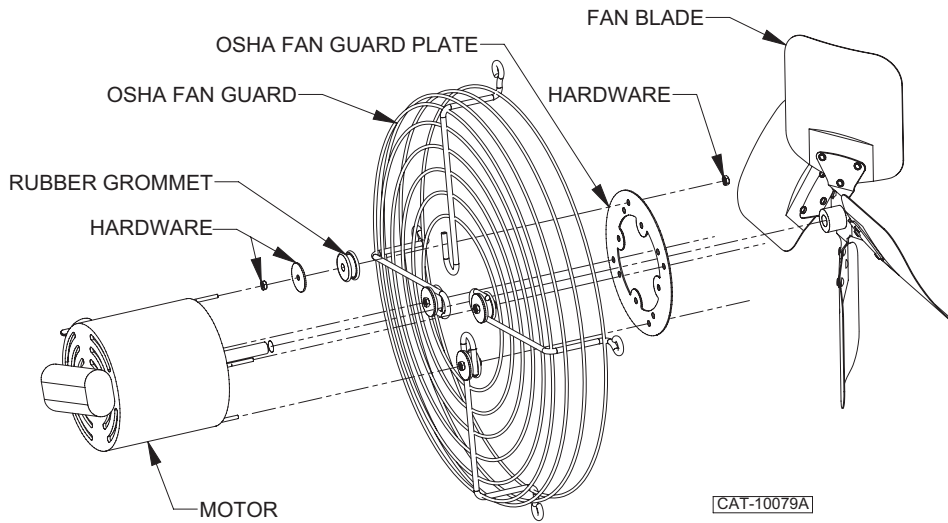

Figure 23 - Electrical Panel

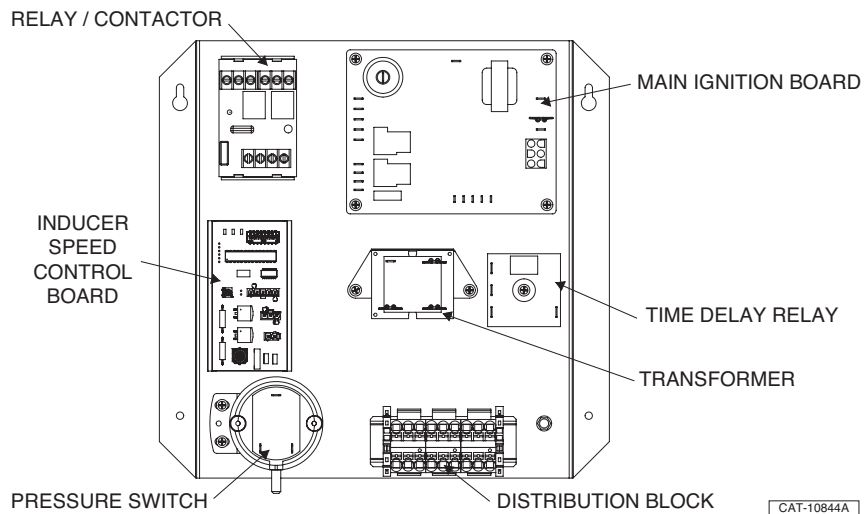

Figure 24 - Power Venter Assembly

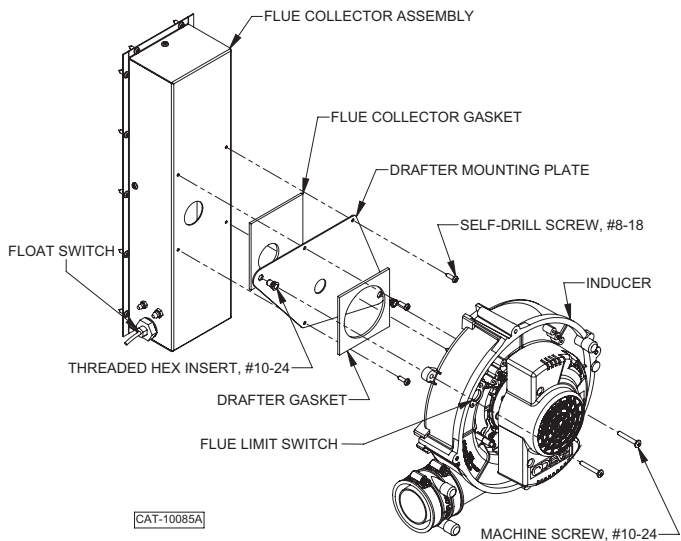

Figure 25 - Direct Spark Ignition System

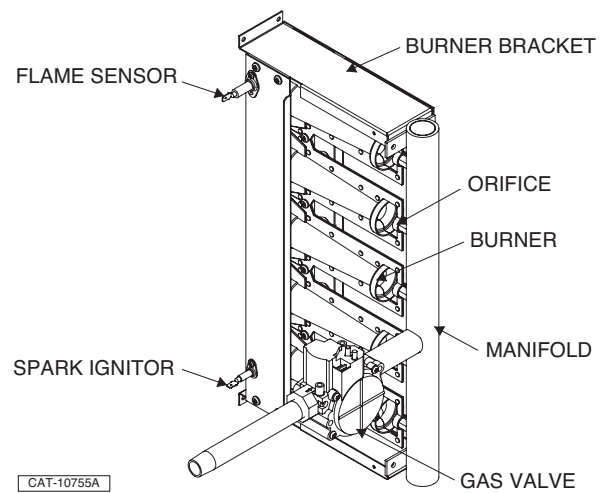
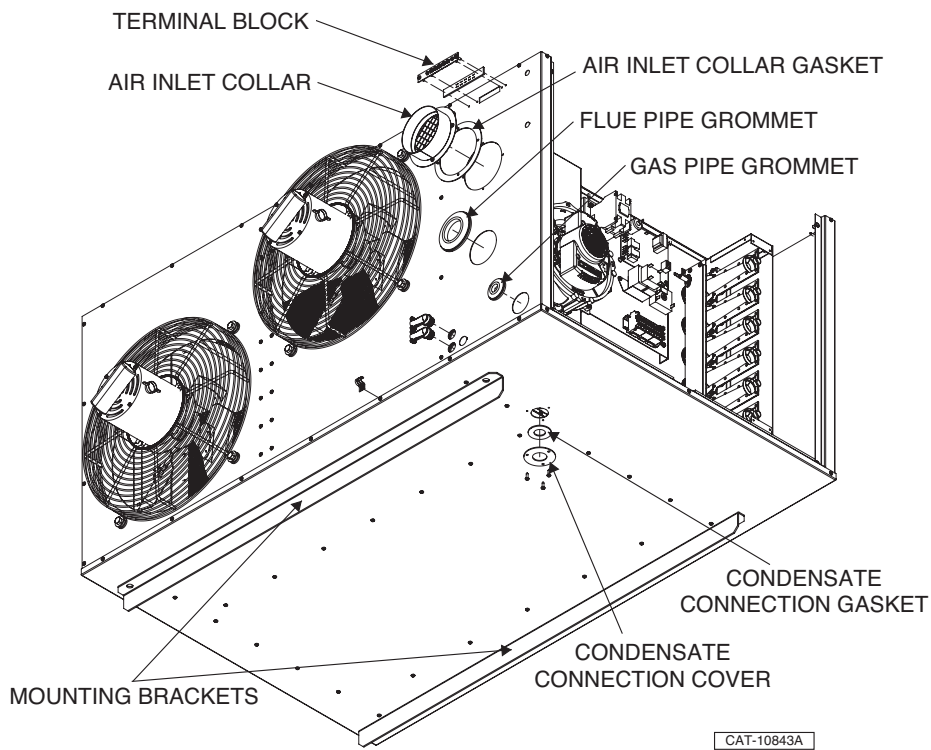

Figure 26 - Unit Connections



HOW TO ORDER REPLACEMENT PARTS

Please send the following information to your local representative: if further assistance is needed, contact the manufacturer's customer service department.

- Unit Number
- Serial Number
- Part Description and Number as shown in Replacement parts Catalog

HIGH EFFICIENCY GAS-FIRED PROPELLER UNIT HEATER UNIT NUMBER DESCRIPTION

DIGIT	D	X	X	X	-	1	2	3	4	5	6	7	8	9	10	11	12	13	14	15	+
ITEM	PREFIX					UT		CA			FT	FM	GT	AL	GC	SV	MT	MS	DL	AS	

(Internal Use Only)

1, 2 - Unit Type [UT]

XH/BXH - High Efficiency Gas-Fired Propeller Unit Heater

3, 4, 5 - Capacity [CA]

050 - 50,000 BTU/HR (14.6 kW)
 100 - 100,000 BTU/HR (29.3 kW)
 150 - 150,000 BTU/HR (43.9 kW)
 200 - 200,000 BTU/HR (58.6 kW)
 250 - 250,000 BTU/HR (73.2 kW)
 300 - 300,000 BTU/HR (87.9 kW)
 350 - 350,000 BTU/HR (102.5 kW)
 400 - 400,000 BTU/HR (117.2 kW)

6 - Furnace Type [FT]

A - Right Side Access

7 - Heat Exchanger (Furnace) Material [FM]

1 - 409 Stainless Steel w/Aluminum and Brass Fins
 Note: Stainless Steel Flue Collector is standard.

8 - Gas Type [GT]

N - Natural Gas
 P - Propane Gas (LP)

9 - Altitude [AL]

S - 0-4,999 ft.
 T - 5,000-11,999 ft.
 Note: Installations over 2,000 ft. require gas input deration in the field. Refer to unit installation instructions.

10 - Direct Spark Gas Control [GC]

1 - Single Stage
 2 - Two Stage
 3 - Electronic Modulation w/Room Sensing
 6 - Electronic Modulation w/External 4-20 mA Input
 7 - Electronic Modulation w/External 0-10 VDC Input

11 - Supply Voltage [SV]

1 - 115/1/60 5 - 230/3/60
 2 - 208/1/60 6 - 460/3/60
 3 - 230/1/60 7 - 575/3/60
 4 - 208/3/60 Z - Special

Note: Supply Voltages [SV] 2-7 include field mounted step down transformer.

12 - Motor Type [MT]

1 - Open Drip Proof

13 - Blower Motor Sizes [MS]

0 - Not applicable

14 - Design Level [DL]

A - First design level

15+ - Accessories [AS]

† FIELD INSTALLED (AS-____)

† All Field Installed Accessories are to be entered as a separate line item using the catalog number which utilizes "11AS" as a prefix. i.e: G3 becomes 11AS-G3.

A7 - High Pressure Regulator
 A7-1/2-1 - Regulator for PSI range 0.5-10
 A7-3/8-1 - Regulator for PSI range 10-20
 A7-5/16-1 - Regulator for PSI range 20-35

E9 - Condensate Neutralizer (Inline)
 EW - Condensate Neutralizer (Wall Mounted)

G1 - 1-Stage Mercury Free Thermostat
 G2 - 1-Stage Mercury Free Thermostat w/Guard Kit
 G3 - 1-Stage Mercury Free Thermostat w/Fan Switch
 G6 - Locking Thermostat Cover
 G9 - 1-Stage Mercury Free Heating Only Thermostat
 GW - WiFi Thermostat TH8321WF1001/U

K8 - Condensate Pump
 K9-001 - Condensate Pump Shelf

Y2 - 2" Concentric Vent Kit
 Y3 - 3" Concentric Vent Kit
 Y4 - 4" Concentric Vent Kit

GAS EQUIPMENT START-UP AND INSPECTION SHEET

Customer _____ Job Name & Number _____

PRE-INSPECTION INFORMATION

With power and gas off.

Type of Equip: Unit Heater

Serial Number _____ Model Number _____

Name Plate Voltage: _____ Name Plate Amperage: _____

Type of Gas: Natural LP Tank Capacity _____ lbs. Rating: _____ BTU @ _____ °F
_____ kg _____ kw @ _____ °C

- Are all panels, doors, vent caps in place?
- Has the unit suffered any external damage? Damage _____
- Does the gas piping and electric wiring appear to be installed in a professional manner?
- Has the gas and electric been inspected by the local authority having jurisdiction?
- Is the gas supply properly sized for the equipment?
- Were the installation instructions followed when the equipment was installed?
- Have all field installed controls been installed?
- Do you understand all the controls on this equipment? ***If not, contact your wholesaler or rep. (DO NOT START this equipment unless you fully understand the controls.)***

GENERAL

With power and gas off.

- Make certain all packing has been removed.
- Tighten all electrical terminals and connections.
- Check all fans & blowers for free movement.
- Check all controls for proper settings.

FAN

With power and gas off.

- Check voltage L1___ L2___ L3___
- Check rotation of main fan.
- Check motor amps L1___ L2(N)___

GAS HEATING

With power and gas on.

- Inlet gas pressure. _____ in. W.C. or _____ kPa
- Burner ignition.
- Manifold gas pressure. _____ in. W.C. or _____ kPa
- Check electronic modulation. Set at: _____
- Cycle and check all other controls not listed.
- Entering air temp. _____ °F or _____ °C
- Discharge air temp. (High Fire) _____ °F. or _____ °C
- Cycle by thermostat or operating control.
- Combustion Readings:
Carbon Monoxide: _____ PPM
Carbon Dioxide: _____ %

Remarks: _____



MESTEK, INC.

260 NORTH ELM ST., WESTFIELD, MA 01085
TEL: (413) 564-5540
www.mestek.com

