

# BEACON/MORRIS BMSB SEPARATED COMBUSTION BLOWER UNIT HEATER

BVSB-9

## DESCRIPTION

The BMSB Separated Combustion Unit Heater is a great addition to Beacon/Morris' 80% efficient indoor product line. Separated combustion units are designed to be installed where dusty, dirty or mildly corrosive conditions exist or where high humidity or slightly negative pressures prevail. Available sizes range from 100,000 through 400,000 BTU/HR inputs.



## CERTIFICATION

The BMSB unit is certified by ETL to provide a minimum of 80% efficiency.

## BASIC OPERATION

Beacon/Morris Model BMSB Blower Unit Heaters "separate" the combustion process from the environment where the unit is installed. A power venting system draws a controlled quantity of combustion air from outside the building. The same system exhausts flue products to the outside. The burners, pilot and flue system are enclosed within the unit; thus, the entire combustion process is unaffected by the atmosphere in the space where the heater is located.

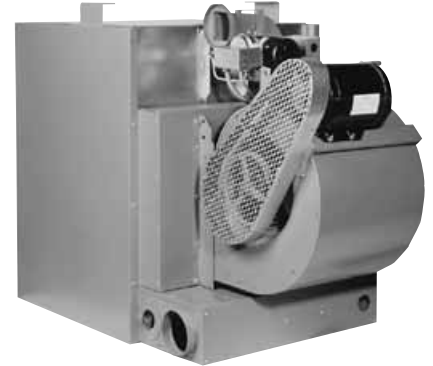

## STANDARD FEATURES AND BENEFITS INCLUDE:

- 20-gauge Aluminized Steel Heat Exchanger
- Power Venter
- Combustion Air Pressure Switch
- Spark-ignited Intermittent Safety Pilot with Electronic Flame Supervision
- Fan Time Delay
- Certified for Natural or Propane Gas
- 115/24 Volt Transformer
- 115/1/60 O.D.P. Blower Motor
- Redundant Single-stage Gas Valve
- High Limit Switch
- Combustion air and flue may be piped horizontally through sidewall or vertically through the roof.

## FACTORY INSTALLED OPTIONS

- 409 or 321 Stainless Steel Heat Exchanger
- 409 Stainless Steel Burners
- Two Stage Gas Valves and Electronic Modulation Controls
- TEFC Premium Efficiency ODP or TEFC Blower Motors
- Alternate Voltages: 208, 230/1/60; 208, 230, 460, 575/3/60

## FIELD INSTALLED OPTIONS

- Summer/Winter Switch
- Discharge Nozzle: 30°, 60°, 90° and Y Splitter
- Outlet Duct Flange (in Lieu of Standard Horizontal Louvers)
- Thermostats
- 5 to 4 in. Venter Decrease Adapter to Flue Pipe
- 4, 5 and 6 in. Vent Termination Cap
- Horizontal and Vertical Concentric Vent Kits
- Vertical Louvers

## CAUTIONS

Combustion air and vent systems must be installed in accordance with current National Fuel Gas Code or Installation Code, Installation Code for Natural Gas Burning Appliances and Equipment (Canada) and any local and state codes.

Units should not be installed where negative pressures are significant, where vapor containing chlorine or fluorine may be present or in any areas classified as "HAZARDOUS."



260 North Elm Street • Westfield, MA 01085  
Tel: (413) 562-5423 Fax: (413) 572-3764



PROJECT: \_\_\_\_\_

UNIT TAG: \_\_\_\_\_

# BMSB – PERFORMANCE AND DIMENSIONAL DATA

Capacity (MBH)	100	125	150	175	200	225	250	300	350	400
<b>PERFORMANCE DATA †</b>										
Input BTU/Hr (kW)	100,000 (29.3)	125,000 (36.6)	150,000 (43.9)	175,000 (51.2)	200,000 (58.6)	225,000 (65.9)	250,000 (73.2)	300,000 (87.8)	350,000 (102.5)	400,000 (117.1)
Output BTU/Hr (kW)	80,000 (23.4)	100,000 (29.3)	120,000 (35.1)	140,000 (41.0)	160,000 (46.9)	180,000 (52.7)	200,000 (58.6)	240,000 (70.3)	280,000 (82.0)	320,000 (93.7)
Thermal Efficiency (%)	80	80	80	80	80	80	80	80	80	80
Free Air Delivery CFM (cu. m/s)	1,200 (0.566)	1,575 (0.743)	1,975 (0.932)	2,300 (1.086)	2,400 (1.133)	2,600 (1.227)	2,850 (1.345)	3,950 (1.864)	4,600 (2.171)	4,800 (2.266)
Air Temperature Rise °F (°C)	62 (34)	59 (33)	56 (31)	56 (31)	62 (34)	64 (36)	65 (36)	56 (31)	56 (31)	62 (34)
Outlet Velocity FPM (m/s)	880 (4.47)	950 (4.83)	1030 (5.23)	1045 (5.31)	965 (4.90)	935 (4.75)	930 (4.72)	1080 (5.49)	1090 (5.54)	1000 (5.08)
Full Load Amps at 115V (O.D.P.)	7.0	8.0	9.1	9.1	13.5	13.5	13.5	13.5	14.9	14.9
<b>MOTOR DATA:</b>										
Motor HP	1/4	1/3	1/2	1/2	3/4	3/4	3/4	3/4	1	1
Motor (kW)	(0.19)	(0.25)	(0.37)	(0.37)	(0.56)	(0.56)	(0.56)	(0.56)	(0.75)	(0.75)
Motor Type (O.D.P.)	SPH	SPH	SPH	SPH	SPH	SPH	SPH	SPH	cap.start	cap.start
RPM	1725	1725	1725	1725	1725	1725	1725	1725	1725	1725
Amps @ 115V (O.D.P.)	5.1	6.1	7.2	7.2	11.6	11.6	11.6	11.6	13.0	13.0
<b>DIMENSIONAL DATA in. (mm)</b>										
"A" Height to Top of Unit	31-1/4 (794)	31-1/4 (794)	36-1/4 (921)	36-1/4 (921)	36-1/4 (921)	36-1/4 (921)	36-1/4 (921)	36-1/4 (921)	36-1/4 (921)	36-1/4 (921)
"B" Height to Top of Hanger	34-1/16 (865)	34-1/16 (865)	39-1/16 (992)	39-1/16 (992)	39-1/16 (992)	39-1/16 (992)	39-1/16 (992)	39-1/16 (992)	39-1/16 (992)	39-1/16 (992)
"C" Hanging Distance Width	14-3/4 (375)	17-1/2 (444)	17-1/2 (444)	20-1/4 (514)	23 (584)	25-3/4 (654)	28-1/2 (724)	34 (864)	39-1/2 (1003)	45 (1143)
"D" Discharge Opening Width	15-3/8 (391)	18-1/8 (460)	18-1/8 (460)	20-7/8 (530)	23-5/8 (600)	26-3/8 (670)	29-1/8 (740)	34-5/8 (879)	40-1/8 (1019)	45-5/8 (1159)
"E" Width of Unit	17-7/8 (454)	20-5/8 (524)	20-5/8 (524)	23-3/8 (594)	26-1/8 (664)	28-7/8 (733)	31-5/8 (803)	37-1/8 (943)	42-5/8 (1083)	48-1/8 (1222)
"F" to Centerline of Flue	5-7/8 (149)	7-1/4 (184)	7-1/4 (184)	8-5/8 (219)	10 (254)	11-1/4 (286)	12-3/4 (324)	15-1/2 (394)	18-1/4 (464)	21 (533)
"G" Hanging Distance Depth	18-1/2 (470)	18-1/2 (470)	18-1/2 (470)	20 (508)	20 (508)	23 (584)	23 (584)	23 (584)	23 (584)	23 (584)
"H" Depth to Rear of Housing	42-3/4 (1086)	44-3/8 (1127)	44-3/8 (1127)	47-3/16 (1199)	47-3/16 (1199)	50-7/8 (1292)	48 (1219)	50-7/8 (1292)	50-7/8 (1292)	51 (1295)
Flue Size Dia-in.** (Dia-mm)	4 (102)	4 (102)	4 (102)	4 (102)	5 (127)	5 (127)	5 (127)	6 (152)	6 (152)	6 (152)
Air Inlet Size-in. (mm)	4 (102)	4 (102)	4 (102)	4 (102)	5 (127)	5 (127)	5 (127)	6 (152)	6 (152)	6 (152)
Blower Size-in.	9	10	10	12	12	12	12	(2)10	(2)12	(2)12
Gas Inlet-Natural Gas-in.	1/2	1/2	1/2	1/2	1/2	3/4	3/4	1/2 or 3/4		3/4
Gas Inlet-LP Gas-in.	1/2	1/2	1/2	1/2	1/2			1/2 or 3/4		3/4
Approx. Shipping Wt. lb. (kg)	298 (135)	330 (150)	362 (164)	394 (179)	426 (193)	458 (208)	490 (222)	558 (253)	618 (280)	678 (308)

† Ratings shown are for unit installations at elevations between 0 and 2000 ft. (610m). For unit installations in USA above 2000 ft. (610m), the unit input must be derated 4% for each 1000 ft. (305m) above sea level; refer to local codes, or in absence of local codes, refer to the latest edition of the National Fuel Gas Code, ANSI Standard Z223.1 (N.F.P.A. No. 54).

For installations in Canada, any references to deration at altitudes in excess of 2000 ft. (610m) are to be ignored. At altitudes of 2000 to 4500 ft. (610 to 1372m), the unit must be derated to 90% of the normal altitude rating, and be so marked in accordance with the ETL certification.

LEGEND: SPH = SPLIT PHASE CAP. START = CAPACITOR START O.D.P. = OPEN DRIP PROOF

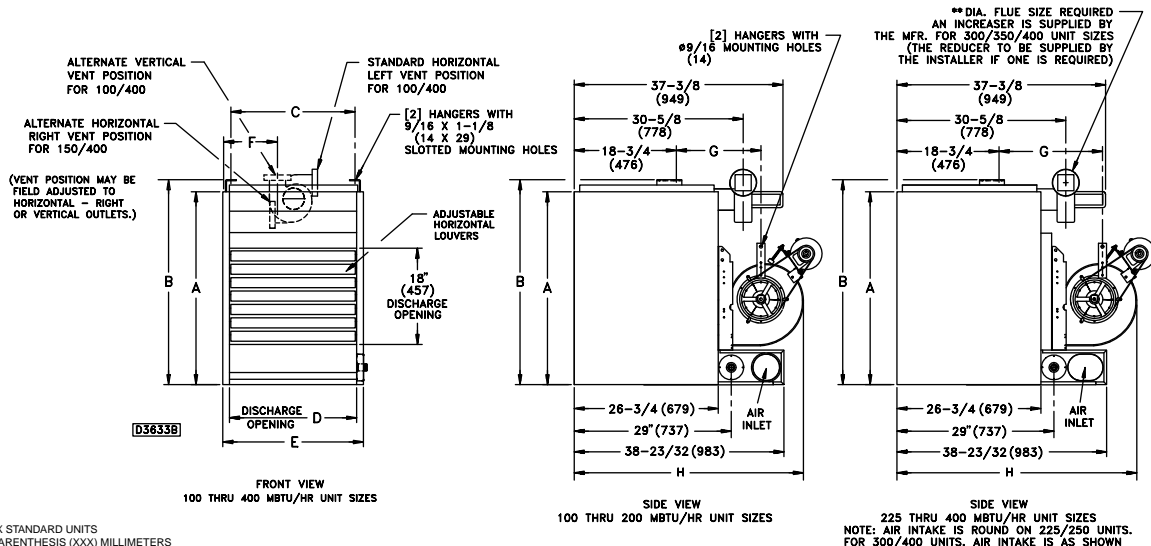

DIMENSIONS .XXX STANDARD UNITS  
DIMENSIONS IN PARENTHESIS (XXX) MILLIMETERS