

97%\*  
Full Input  
Thermal Efficiency

# OPTUM

Gas-Fired High Efficiency Unit Heater



  
Beacon Morris®



# OPTUM

## The World's Best High Efficiency Unit Heater



*"The less fossil fuels we burn the better it is for our future; all of my designs concentrate on this philosophy. We lead in innovation using the environment as our number one concern. We don't follow...we lead."*

*-Ken Cohen, Designer*

Beacon Morris' **Optum** brings gas-fired unit heaters to unprecedented levels of efficiency. Its industry leading 99%\* thermal efficiency combines the latest innovations, including a tri-metal stainless steel heat exchanger and a state-of-the-art proprietary combustion control system.

Efficiency matters...not only is the **Optum** the most energy efficient unit heater available, it is the most environmentally friendly too. Reduced emissions, low fuel utilization and a reduced carbon footprint give **Optum** our green stamp of approval!

\*Efficiencies vary by size. 97% certified efficiency at high fire (BH050). Up to 99% maximum efficiency at full turndown.

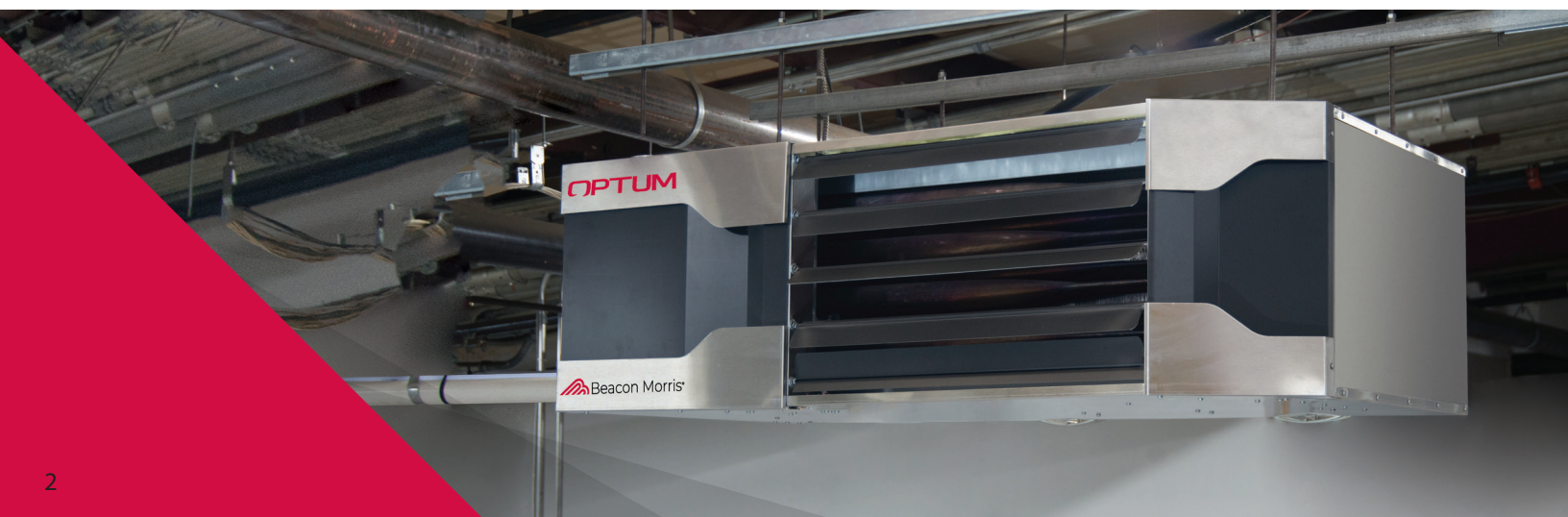

## Application Flexibility

In today's marketplace where time is money, **Optum** is designed to be user and service friendly. Whether natural or LP gas, conversions are simple and quick through a single orifice conversion with kits included as a standard feature. Multiple operating voltages, flexible venting options and some of the longest throws in the segment make **Optum** the only choice for any application. Units can operate in a single unit mode, multi-unit networks or linked to a building management system with seamless control communication.

## Sophisticated Styling

**Optum** brings a whole new look to the unit heater arena with a beautiful commercial-grade brushed stainless steel jacket with contrasting black trim. Its corrosion resistant exterior and double-wall construction provide both durability and increased efficiency through reduced heat loss...appealing and functional.

## Heat Exchanger

**Optum's** tri-metal heat exchanger is the most advanced on the market today. Engineered for maximum efficiency; our tri-metal hybrid design utilizes all of today's technologies for optimum heat transfer.

A unique combination of metals and tube configurations scrub every last bit of heat energy from the combustion process. The use of stainless steel with high conductivity brass and even higher conductivity aluminum all working in conjunction with turbulators to improve the heat transfer from the hot flue gases to the bi-metal fins produces up to 97% operating efficiency at full fire.

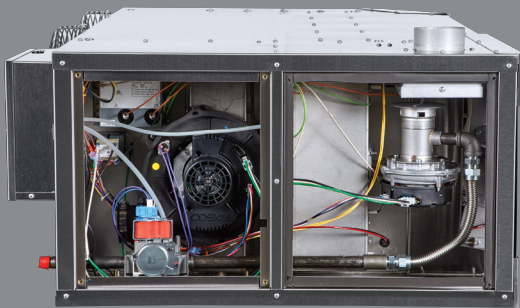
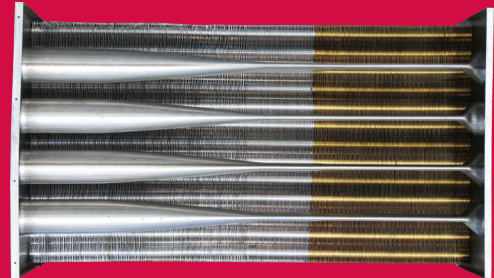

## Altitude Auto-Adjust

Units auto-adjust the air/fuel mixture for altitude adjustments so there are no field adjustments required.

**Optum** also has **SafeSense** technology for blocked inlet/flue conditions. Units will maintain clean combustion in a partial blockage situation without decreasing performance insuring safe combustion at all times. In a situation of unsafe combustion, units will shut themselves down until the necessary corrective actions are completed.

## Safety & Performance

Premium performance in the safest possible way... All units use Beacon Morris' proprietary combustion control platform which guarantees clean combustion regardless of the operating conditions.

Combustion is constantly monitored through **Optum's** electronic air/fuel coupling control platform, consistently maintaining safe levels of emissions.

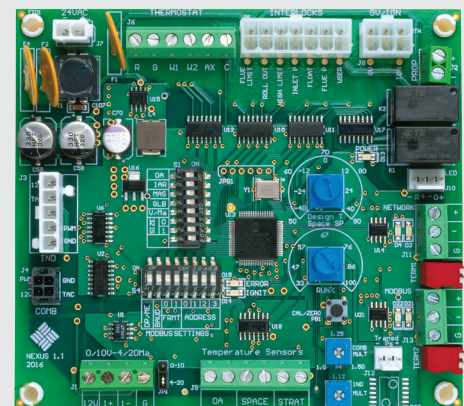

# OPTUM

## Gas Controls

The only fully modulating, high efficiency unit heater produced, **Optum** utilizes a burner control and configuration that allows a 3:1 turndown for precision discharge temperature control, with this technology units run more efficiently for a longer period of time with reduced cycling. Competitors use in-shot burners and only offer 1:1 on/off configuration that often times result in over/under heating the occupied space and increased wear and tear on the equipment with constant cycling.

## Indoor Air Reset

**Optum's** indoor air reset technology essentially learns the heating needs of the building by constantly monitoring run-time percentages and modulates accordingly.

Indoor Air Reset allows **Optum** to operate at full modulation (low fire) for as long as reasonable to maintain the heating load. By running at low fire units run longer at higher efficiency resulting in less cycling, lower fuel costs and increased occupancy comfort.

## Modbus Communication to Building Automation System

The **Optum** Control Board includes Modbus communication as a standard feature without requiring additional control modules. The control board provides feedback to the building automation system allowing for the remote monitoring of over 30 data points including unit fault codes. This allows user to know what is wrong with the unit without even entering the building.

## Stratification Sensor

The optional stratification sensor allows the unit to take advantage of excess heat that may be up at the ceiling to provide "free" heating to the space. When the sensor detects air stratification near the unit, the unit will re-use that excess heat to warm the occupied area of the space without the need for mechanical (gas) heat, resulting in a lower fuel cost.



## Outdoor Air Reset Modulation

Units automatically vary discharge temperatures based on the outside air temperature providing seamless modulation for optimum efficiencies. By running at lower discharge temperatures subject to the outdoor temperatures, units run longer at higher efficiency resulting in less cycling, lower fuel costs, and increased occupancy comfort. As the outdoor temperature drops, discharge temperatures increase and vice versa. Outdoor Air Reset is optimal in regions with substantial daily temperature swings.

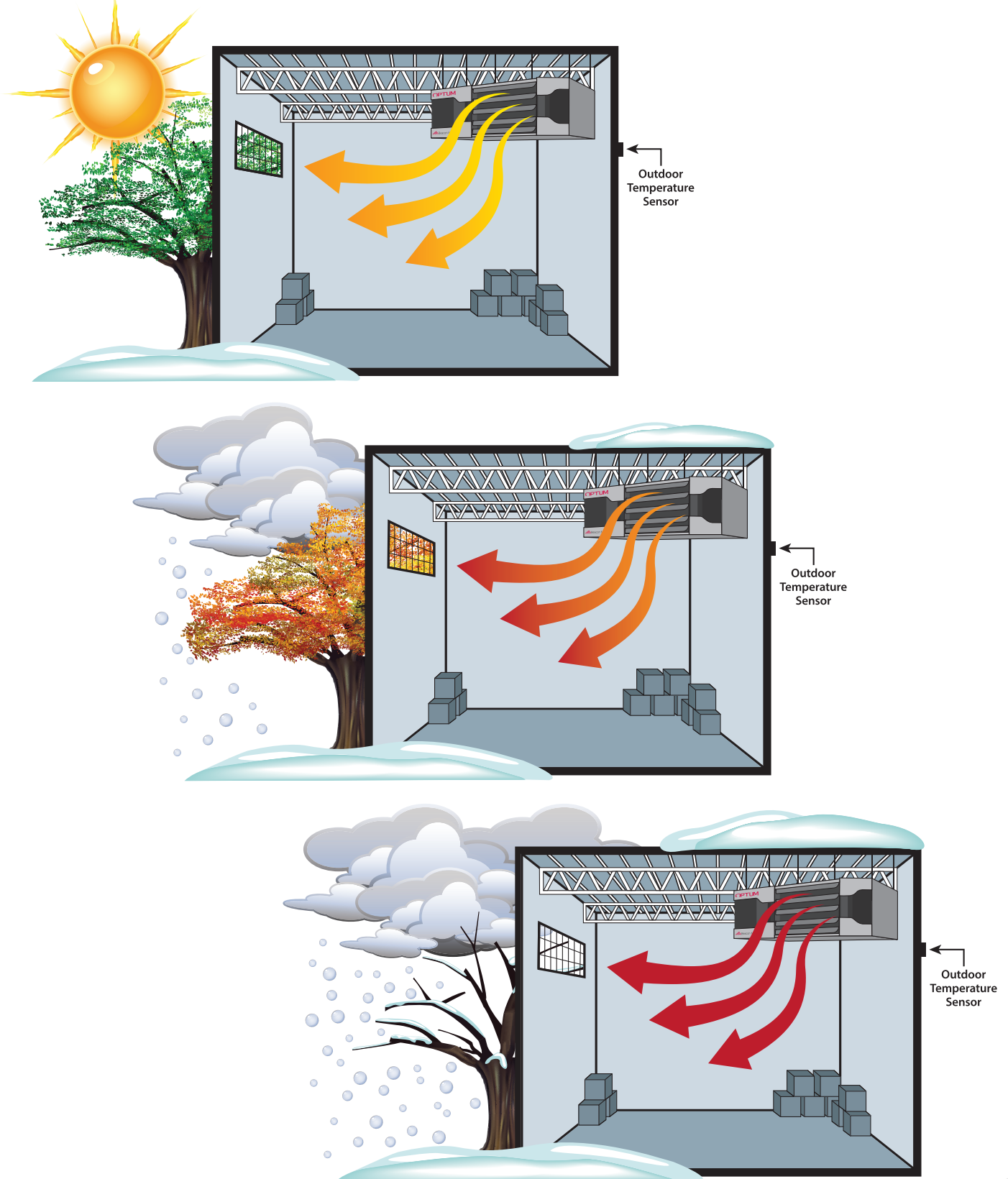

# OPTUM

## BH050 Dimensional Data

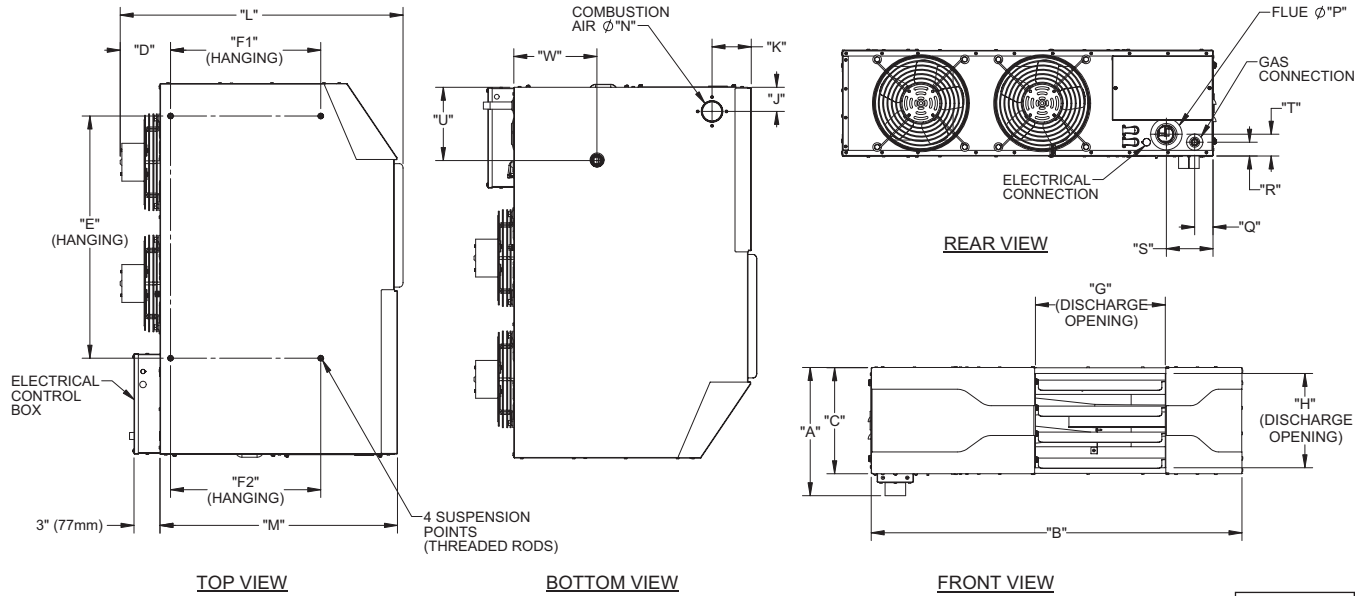

## BH100-400 Dimensional Data

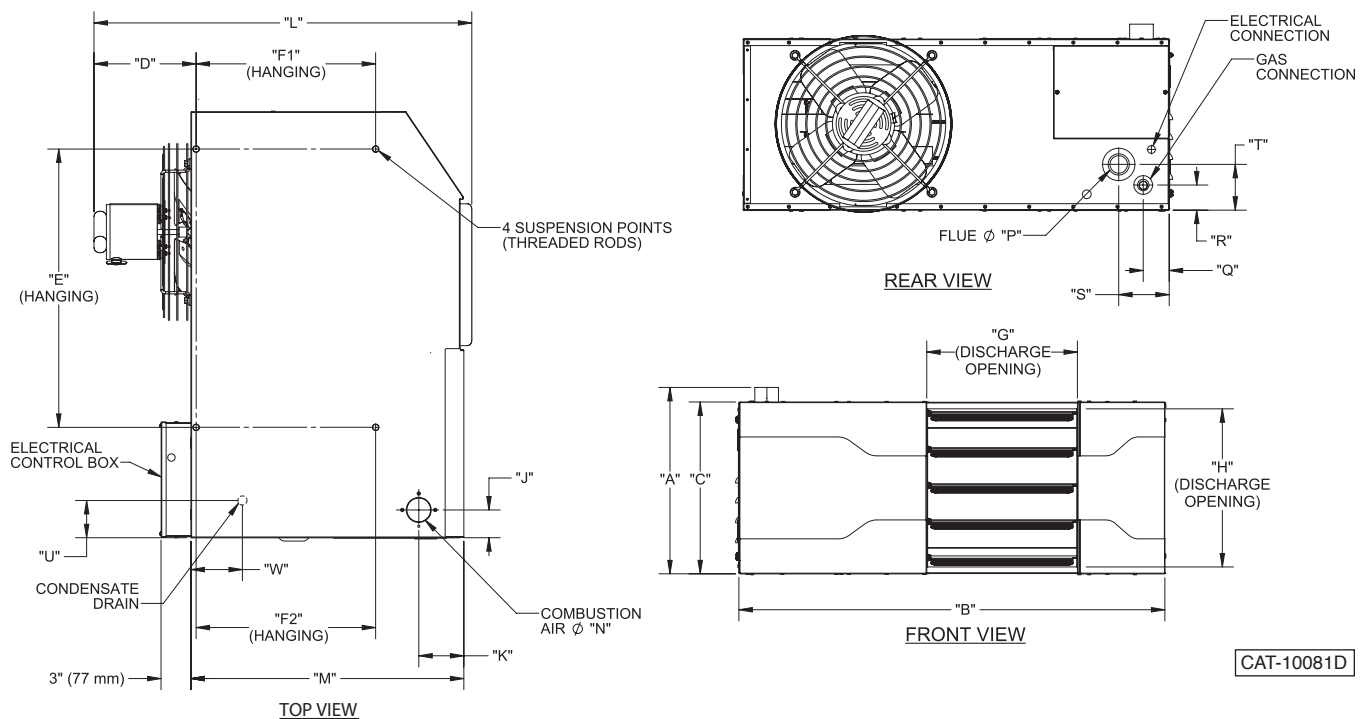



## Dimensional Data

Unit Capacity (MBH)		50	100	150	200	300	400
<b>DIMENSIONAL DATA - inches (mm)</b>							
"A" Height to Top of Combustion Air Inlet		13-5/8 (346)	18-3/4 (476)	18-3/4 (476)	18-3/4 (476)	27-1/8 (689)	34-7/8 (886)
"B" Jacket Width of Unit		42-13/16 (1087)	42-13/16 (1087)	54-13/16 (1392)	54-13/16 (1392)	54-13/16 (1392)	54-13/16 (1392)
"C" Unit Height		12-1/4 (311)	17-1/4 (438)	17-1/4 (438)	17-1/4 (438)	25-11/16 (653)	33-7/16 (850)
"D" Depth to Rear of Housing		5-3/4 (147)	11 (279)	10-5/16 (261)	11 (279)	10-7/8 (277)	11-1/2 (292)
"E" Hanging Distance Width		28 (710)	27-15/16 (710)	38 (965)	38 (965)	41-3/4 (1060)	41-3/4 (1060)
"F1" Hanging Distance Depth		17-3/8 (440)	17-1/4 (438)	21-1/8 (537)	21-1/4 (540)	20 (508)	20 (508)
"F2" Hanging Distance Depth		17-3/8 (440)	17-1/4 (438)	21-1/8 (537)	21-1/4 (540)	26 (660)	26 (660)
"G" Discharge Opening Width		15 (381)	15 (381)	26 (660)	26 (660)	26 (660)	26 (660)
"H" Discharge Opening Height		10-1/8 (256)	15-7/8 (403)	15-7/8 (403)	15-7/8 (403)	24-3/8 (619)	32-1/8 (816)
"J" Side Panel to Centerline Combustion Air		2-3/4 (70)	2-13/16 (71)	3-3/4 (95)	3-3/4 (95)	3-3/4 (95)	3-3/4 (95)
"K" Front Panel to Centerline Combustion Air		4-1/2 (115)	4-1/2 (114)	5-5/16 (135)	5-5/16 (135)	5-5/16 (135)	5-5/16 (135)
"L" Overall Unit Depth		32-5/8 (829)	38 (965)	41 (1040)	42 (1067)	42 (1067)	42 (1067)
"M" Side Depth		27-7/16 (696)	27-7/16 (697)	31-1/4 (794)	31-1/4 (794)	31-1/4 (794)	31-1/4 (794)
"N" Combustion Air Inlet Connection Dia.		2 (51)	2 (51)	2 (51)	3 (76)	4 (102)	4 (102)
"P" Flue Connection Diameter		2 (51)	2 (51)	2 (51)	3 (76)	4 (102)	4 (102)
"Q" Side Panel to Centerline Gas Connection		2-1/8 (54)	2-5/8 (67)	2-5/8 (67)	2-5/8 (67)	2-5/8 (67)	2-5/8 (67)
"R" Bottom Panel to Centerline Gas Connection		1-1/2 (40)	2-1/2 (64)	2-1/2 (64)	2-1/2 (64)	2-1/2 (64)	2-1/2 (64)
"S" Side Panel to Centerline Flue		5-3/8 (137)	5-1/8 (130)	6-1/2 (165)	6-1/16 (154)	5-3/8 (137)	5-3/8 (137)
"T" Bottom Panel to Centerline Flue		2-1/2 (64)	4-5/8 (117)	4-5/8 (117)	4-5/8 (117)	8-1/8 (206)	13-1/8 (334)
"U" Side to Centerline Condensate Drain Connection		8-1/2 (214)	8-1/2 (216)	9-1/2 (241)	9-1/2 (241)	9-1/2 (241)	9-1/2 (241)
"W" Rear to Centerline Condensate Drain Connection		9-9/16 (243)	9-9/16 (243)	10-9/16 (268)	10-9/16 (268)	10-1/8 (257)	10-1/8 (257)
Approximate Unit Weight -	lb	120	180	209	260	323	385
	(kg)	(54.4)	(81.6)	(94.8)	(117.9)	(146.5)	(174.6)
Approximate Ship Weight -	lb	168	228	254	305	388	460
	(kg)	(76.2)	(103.4)	(115.2)	(138.3)	(176.0)	(208.6)

# OPTUM



## Specifications

Model		BH050	BH100	BH150	BH200	BH300	BH400
Input	BTU/HR	50,000	100,000	150,000	200,000	300,000	400,000
	KW	14.6	29.3	43.9	58.6	87.9	117.2
Output	BTU/HR	48,600	96,000	143,000	192,000	285,000	384,000
	KW	14.0	28.1	42.6	56.0	82.8	109.0
Thermal Efficiency		97%	96%	95%	96%	95%	96%
Air Temp Rise	DEG. F	57	55	50	55	55	55
	DEG. C	31.7	30.6	27.8	30.6	30.6	30.6
Condensate Production	GAL/HR	0.41	0.73	1.06	1.38	1.71	3.00
Turn Down Ratio		3:1	3:1	3:1	3:1	3:1	3:1
Modulating Control		YES	YES	YES	YES	YES	YES
Fuel Type		NG/LP	NG/LP	NG/LP	NG/LP	NG/LP	NG/LP
Venting Category		IV	IV	IV	IV	IV	IV
Airflow	CFM	790	1,616	2,661	3,232	4,848	6,464
	CU. M/S	0.373	0.763	1.256	1.525	2.288	3.051
Outlet Velocity	FPM	697	977	928	1,127	1,101	1,114
	FT	50*	150	100	150	150	150
Heat Throw @ 20 ft. (6.10 m) Mounting Height	M	15.24	45.72	30.48	45.72	45.72	45.72
	INCH W.C.	5	5	5	5	5	5
Min. Gas Pressure NG	KPA	1.24	1.24	1.24	1.24	1.24	1.24
	INCH W.C.	8	8	8	8	8	8
Min. Gas Pressure LP	KPA	1.99	1.99	1.99	1.99	1.99	1.99
	INCH W.C.	14	14	14	14	14	14
Max. Gas Pressure NG / LP	KPA	3.48	3.48	3.48	3.48	3.48	3.48
	HP	1/14	1/2	1/12	1/2	1	1
Motor Size	KW	0.05	0.37	0.06	0.37	0.74	0.74
	Motor Qty	2	1	2	2	2	2
Motor RPM		1,500	1,500	1,500	1,500	1,625	1,625
Gas Connection Size		1/2"	1/2"	1/2"	1/2"	3/4"	3/4"
Condensate Discharge Size		3/4"	3/4"	3/4"	3/4"	3/4"	3/4"
Condensate Trap		YES	YES	YES	YES	YES	YES
Combustion Air Intake	INCH	2	2	2	3	4	4
	MM	50.8	50.8	50.8	76.2	101.6	101.6
Combustion Air Intake Material		PVC/CPVC	PVC/CPVC	PVC/CPVC	PVC/CPVC	PVC/CPVC	PVC/CPVC
Flue Size	INCH	2	2	2	3	4	4
	MM	50.8	50.8	50.8	76.2	101.6	101.6
Flue Material		PVC/CPVC	PVC/CPVC	PVC/CPVC	PVC/CPVC	PVC/CPVC	PVC/CPVC
<b>Electrical Data</b>							
Supply Voltage/Phase		115V - 1PH	115V - 1PH	115V - 1PH	115V - 1PH	115V - 1PH	115V - 1PH
FLA		10.0	10.8	19.5	19.5	31.0	31.0
Motor Amps (total fan motor amps)		5.2	6.0	12.0	12.0	22.0	22.0
<b>Clearance Service/Combustible</b>							
Air Intake Side	INCH	18	18	18	18	36	36
	MM	457.2	457.2	457.2	457.2	914.4	914.4
Access Side	INCH	18	18	18	18	18	18
	MM	457.2	457.2	457.2	457.2	457.2	457.2
Non Access Side	INCH	2	6	6	6	6	6
	MM	50.8	152.4	152.4	152.4	152.4	152.4
Top	INCH	2	6	6	6	6	6
	MM	50.8	152.4	152.4	152.4	152.4	152.4
Bottom	INCH	2	6	6	6	6	6
	MM	50.8	152.4	152.4	152.4	152.4	152.4

\*Model BH050 heat throw value is at 8 ft. (2.44 m) Mounting Height; unit is not designed to be mounted at 20 ft. (6.10 m).



260 North Elm Street | Westfield, MA 01085 | Tel: (413) 562-5423  
 7555 Tranmere Dr. | Mississauga, Ont. L5S 1L4 Canada | Tel: (905) 670-5888  
[www.beacon-morris.com](http://www.beacon-morris.com)