

# MODEL EAC - ESC

Equipment Support • Standard Cant • Aluminum or Steel

## Standard Materials and Construction

### Formed Aluminum Equipment Support

**SHELL &**

**BASEPLATE:** .063" thick (nominal) aluminum alloy 3003-H14. All seams are fully welded and sprayed with protective coating.

**CANT:** Mitered 3" x 3" integral cant.

**REINFORCEMENTS:** On 12" centers.

**NAILER:** Varies by width, factory installed.

**FINISH:** Mill.

### Formed Steel Curb Equipment Support

**SHELL &**

**BASEPLATE:** 18 GA. galvanized steel. All seams are fully welded and sprayed with protective coating.

**CANT:** Mitered 3" x 3" integral cant.

**REINFORCEMENTS:** On 12" centers.

**NAILER:** Varies by width, factory installed.

**FINISH:** Mill.

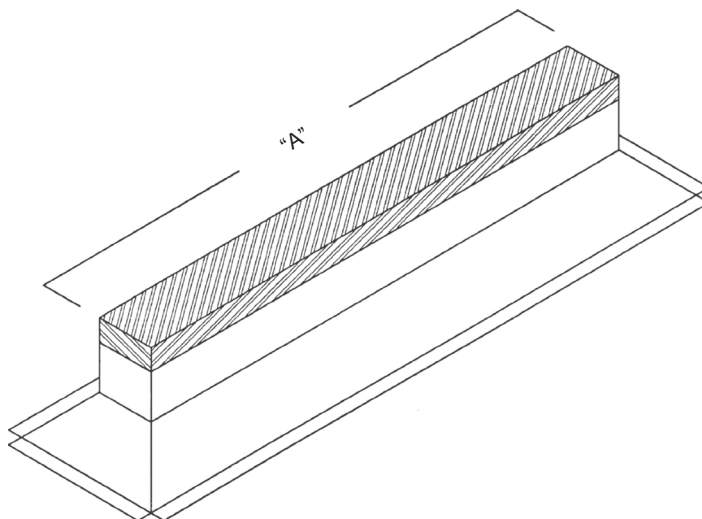

## Options

**Aluminum Material** - Available in .081" - .125" thick 3003-H14 alloy

**Steel Material** - Available in various gauges of galvanized, galvaneal or stainless

**Pitched or Peaked** - In conjunction with the overall dimensions, both the height rise, specified in linear inches per foot (ex: 3" in 12") and the direction of the pitch must be specified.

**Counterflashing** - A removable metal cap fabricated of the same material as the equipment support provides for an effective method of attaching roofing felts.

**Gasket** - 1/4" thick polyurethane foam gasket can be installed, lining the entire top perimeter. Gasket can be used in place of, or in addition to a wood nailer.

**Finishes** - A wide selection of finishes include baked enamel, epoxy, or prime coat.

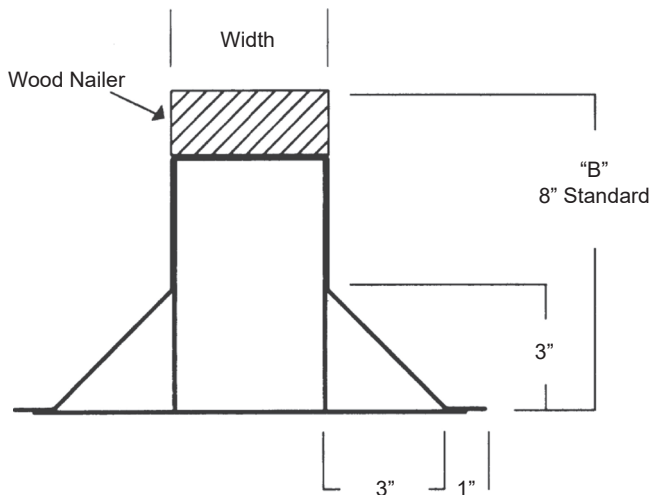

## Notes

1. "A" and "B" are opening dimensions.
2. If height or width exceed 90", multi-section construction may be required.

## Equipment Support Width

Nominal Width	Actual Nailer Width
4"	3 1/2"
6"	5 1/2"
8"	7 1/2"
10"	9 1/2"
12"	11 1/2"

Item #	Qty	"A"	"B"	Width	Material		Pitch / Peak	Direction	Union Made
					Aluminum	Steel			
Arch. / Eng.:		EDR:		ECN:		Job:			
Contractor:									
Project:				Date:		DWN:		DWG:	



In the interest of product development, Arrow United reserves the right to make changes without notice.