

# CONVECTOR

## Submittal

SR-A / SRG-A  
Flat Top Cabinet  
Semi-Recessed  
3 Sided Overlap

### Specification

SR-A Bottom Inlet

**FRONT and LINER:**

STYLE: Front Outlet  
OUTLET: Stamped Louvers  
Pencil Proof

LENGTHS: 20" thru 64" in 4" Increments

MAT'L: Cabinet Front and Liner\*  
 18 Ga./20 Ga. CRS STD.  
 18 Ga./18 Ga. CRS (Opt'l)  
 16 Ga./20 Ga. CRS (Opt'l)  
 16 Ga./18 Ga. CRS (Opt'l)  
 16 Ga./16 Ga. CRS (Opt'l)  
 14 Ga./20 Ga. CRS (Opt'l)  
 14 Ga./18 Ga. CRS (Opt'l)  
 14 Ga./16 Ga. CRS (Opt'l)  
 14 Ga./14 Ga. CRS (Opt'l)

\*Liner is Galvannealed Steel

FINISH:  Prime Finish Std.  
 Baked Enamel (Opt'l).

**ELEMENT:**

COIL: Bronze Header 3/4" NPT  
w/Copper Tube/Alum Fins  
(Mechanically Expanded).

**HEADER CONNECTIONS:**

Single Header Both Ends Std.  
 Single Inlet 1 End / Dual Inlet  
 1 End (Opt'l)  
 Dual Inlet Both Ends (Opt'l)

SRG-A Louvered Inlet

**OPTIONAL ACCESSORIES:**

DAMPER: Damper Blades Factory Installed  
 Knob Damper (Opt'l)  
 Tamper Resistant (Opt'l)

**ACCESS DOORS:**

(Opt'l)

**INSULATION:**

Back Only (Opt'l)  
 Back, Sides, Top (Opt'l)

**PIPING KNOCKOUT:**

(Opt'l)

**4" END POCKETS:**

LH (Opt'l)  
 RH (Opt'l)  
 Both Ends (Opt'l)

**PERFORATED FRONT: Consult Factory**

16 Ga. (Opt'l)  
 14 Ga. (Opt'l)

SR-A Bottom Inlet

SRG-A Louvered Inlet

**TYPE SR-A / SRG-A**

MODEL	D	L	H	B	J
4xx-16	4-1/4	20,24,28,	16	2-1/8	2
4xx-18		32,36,40,	18		
4xx-22		44,48,52,	22		
4xx-24		56,60,64,	24		
4xx-30			30		
6xx-16	6-1/4	20,24,28,	16	3-1/8	4
6xx-18		32,36,40,	18		
6xx-22		44,48,52,	22		
6xx-24		56,60,64,	24		
6xx-30			30		
8xx-16	8-1/4	20,24,28,	16	4-1/8	6
8xx-18		32,36,40,	18		
8xx-22		44,48,52,	22		
8xx-24		56,60,64,	24		
8xx-24			24		
8xx-30			30		

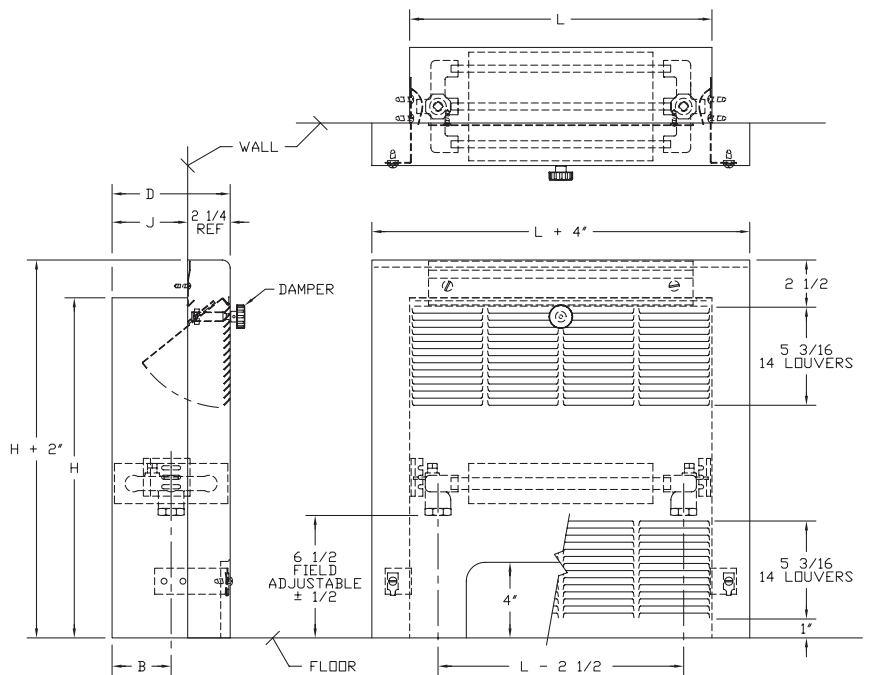

**NOTE: When adding end pockets, liner and front length increase.**



260 North Elm St., Westfield, MA 01085  
 (413) 568-9571 Fax: (413) 562-8437  
 www.airthermhvac.com



PROJECT: \_\_\_\_\_ DATE: \_\_\_\_\_  
 LOCATION: \_\_\_\_\_  
 ARCHITECT: \_\_\_\_\_  
 ENGINEER: \_\_\_\_\_  
 CONTRACTOR: \_\_\_\_\_  
 PO NUMBER: \_\_\_\_\_

## STEAM RATINGS IN BTU/H (215°F at 65°F EAT)

DEPTH IN INCHES	LENGTH IN INCHES	FRONT OUTLET, NOMINAL LINER HEIGHT *TYPE SR-A				
		16"	18"	22"	24"	30"
<b>4</b>	20	2230	2495	2830	2930	3120
	24	2760	3145	3625	3720	3985
	28	3310	3815	4345	4465	4775
	32	3865	4490	5110	5255	5665
	36	4370	5160	5880	6025	6505
	40	4895	5810	6600	6790	7320
	44	5425	6480	7390	7560	8160
	48	5950	7105	8110	8350	8975
	52	6550	7800	8855	9070	9745
	56	7030	8450	9625	9865	10630
	60	7655	9120	10345	10610	11400
64	8135	9790	11135	11400	12290	
<b>6</b>	20	3240	3625	4250	4390	4850
	24	4030	4560	5375	5570	6170
	28	4850	5520	6480	6670	7370
	32	5615	6480	7610	7870	8690
	36	6430	7390	8690	9025	9935
	40	7250	8375	9815	10200	11230
	44	8065	9290	10920	11350	12480
	48	8880	10250	12025	12455	13705
	52	9745	11185	13105	13535	14905
	56	10510	12145	14230	14735	16225
	60	11400	13055	15310	15840	17425
64	12190	14040	16440	17065	18770	
<b>8</b>	20	4030	4535	5040	5135	5570
	24	5110	5760	6360	6575	7105
	28	6385	6960	7680	7895	8520
	32	7560	8185	9025	9310	10055
	36	8710	9385	10390	10705	11545
	40	9865	10630	11760	12070	13055
	44	11040	11830	13055	13440	14545
	48	11950	12935	14400	14810	16080
	52	13465	14230	15670	16105	17425
	56	14615	15505	17090	17570	19010
	60	15770	16655	18335	18840	20375
64	16775	17880	19750	20330	21960	

\* Correction factors for BTU performance from Table 7 must be applied to all units with louvered Inlet.

Correction factors for BTU performance at different Average Water Temperatures, use correction factors from Table 3 of the Correction Factors page.

For other applicable correction factors see the Correction Factors page.

# CONVECTOR BTU CORRECTION FACTORS

**Table 3**

<b>CONVECTOR CORRECTION FACTORS</b> Based on Section 35.4 ASHRAE HVAC Systems and Equipment					
AVERAGE WATER TEMPERATURE (°F)	ENTERING AIR TEMPERATURE (°F)				
	(STD)				
	55°	60°	65°	70°	75°
100°	0.17	0.14	0.12	0.09	0.07
110°	0.23	0.20	0.17	0.14	0.12
120°	0.29	0.26	0.23	0.20	0.17
130°	0.35	0.32	0.29	0.26	0.23
140°	0.43	0.39	0.35	0.32	0.29
150°	0.50	0.46	0.43	0.39	0.35
160°	0.58	0.54	0.51	0.47	0.43
170°	0.67	0.63	0.58	0.54	0.51
180°	0.76	0.71	0.67	0.63	0.58
190°	0.85	0.81	0.76	0.71	0.67
200°	0.95	0.90	0.85	0.81	0.76
210°	1.05	1.00	0.95	0.90	0.85
215° (STD)	1.10	1.05	1.00	0.95	0.90
220°	1.15	1.10	1.05	1.00	0.95
230°	1.26	1.20	1.15	1.10	1.05
240°	1.37	1.32	1.26	1.21	1.15
250°	1.47	1.43	1.37	1.32	1.27

**Table 4**

<b>CORRECTION FACTORS FOR STEAM PRESSURES OTHER THAN 1 PSI GAUGE*</b>						
	PRESSURE PSI GAUGE					
	5	10	15	20	25	50
<b>FACTOR</b>	1.12	1.25	1.36	1.46	1.56	1.93

\*Apply factors shown above to the ratings shown on the 215°F ratings page.

Note: Max Recommended operating pressure 150 PSIG, (365.9°F).  
For conversion from steam to hot water, use correction factors shown in table 3.

**Table 5**

<b>CORRECTION FACTORS FOR ACCESS DOORS</b>								
Length	Free Standing, Non-Recessed Non-Standard Access Door Locations				Semi-Recessed or Fully Recessed Non-Standard Access Door Locations			
	3 or 4	3 & 4	5 or 6	5 & 6	3 or 4	3 & 4	5 or 6	5 & 6
	20"	0.940	0.880	0.820	0.650	0.975	0.950	0.925
24"	0.950	0.910	0.860	0.720	0.980	0.960	0.940	0.880
28"	0.960	0.920	0.890	0.770	0.982	0.968	0.948	0.902
32"	0.970	0.940	0.890	0.800	0.985	0.972	0.955	0.918
36"	0.970	0.940	0.920	0.830	0.988	0.975	0.962	0.925
40"	0.970	0.950	0.920	0.850	0.990	0.978	0.970	0.932
44"	0.980	0.950	0.930	0.860	0.990	0.980	0.970	0.940
48"	0.980	0.960	0.940	0.880	0.990	0.982	0.970	0.948
52"	0.980	0.960	0.950	0.890	0.992	0.985	0.978	0.955
56"	0.980	0.960	0.950	0.890	0.992	0.985	0.978	0.955
60"	0.980	0.970	0.950	0.900	0.992	0.985	0.978	0.955
64"	0.980	0.970	0.950	0.910	0.992	0.988	0.978	0.962

Note: Derating factors do not apply to units with end pockets.

**Table 6**

WATER FLOW IN GPM	PRESSURE LOSS IN FEET OF WATER		
	4 INCH MODELS	6 INCH MODELS	8 INCH MODELS
.25	0.044	—	—
.50	0.160	0.070	0.046
1	0.597	0.270	0.167
2	2.220	1.047	0.616
3	—	2.260	1.367
4	—	3.793	2.380
5	—	—	3.673

Charted figures showing pressure drop through Convectors with forced hot water. Used for determining pressure head requirement. Based on 64" length units, but applicable to shorter units, as most loss is due to headers.

**Table 7**

<b>CORRECTION FACTORS FOR INLET GRILLES</b> TYPES: FSG-A, SRG-A, RFG-A, FWG-A, PWG-A, SFG-A			
DEPTH	HEIGHT		
	16", 18", 20"	22", 24", 26"	28", 30", 32"
4"	0.97	0.98	0.99
6"	0.94	0.95	0.98
8"	0.91	0.93	0.97

Due to the restriction to air flow, the correction factor should be multiplied to the BTU output when inlet grilles are specified.

**ADDITIONAL CORRECTION FACTORS ON NEXT PAGE**

# CONVECTOR BTU CORRECTION FACTORS

## GALLONS PER MINUTE OF HOT WATER REQUIRED

Table 8



## OUTPUT-FLOW RATE CORRECTIONS

Table 9

Convactor Depth	Tubes per Element	Min. Flow Rate (0.25 Ft./Sec.) GPM	MBH Based on T.D. & Min. Flow Rate			
			10TD	20TD	30TD	40TD
4"	2	.15	0.750	1,500	2,250	3,000
6"	3	.225	1.125	2,250	3,375	4,500
8"	4	.30	1.500	3,000	4,500	6,000

NOTE: Table 9 shows MBH which result at specific water temperature drops and minimum water flow rates which are required to maintain turbulent flow within element tubes.

# CONVECTOR COIL

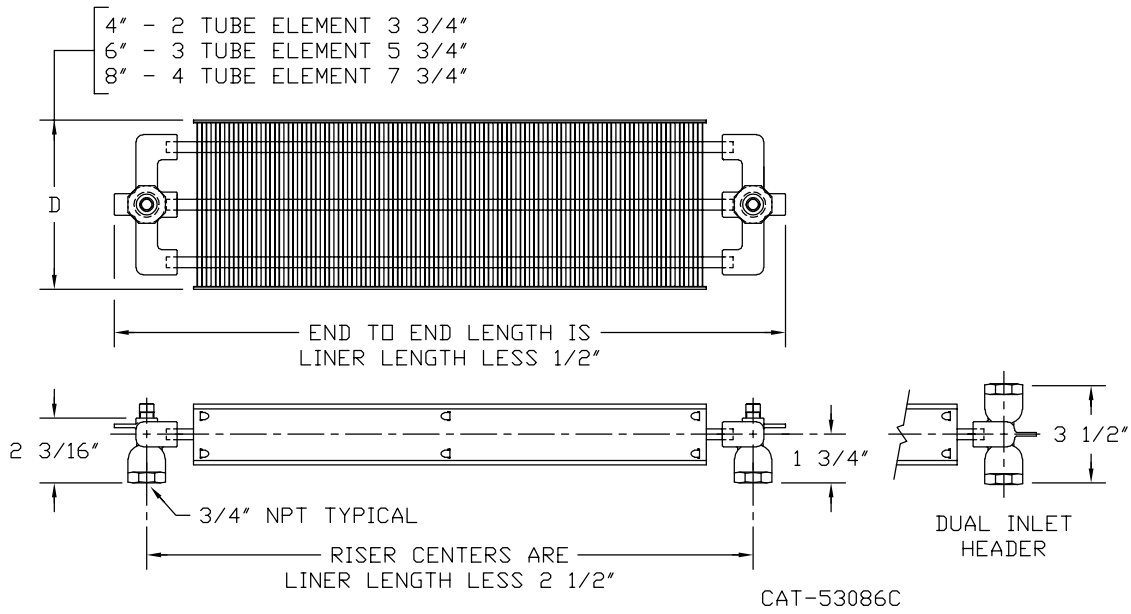

NOTE: When ordering convectors with end pockets always refer to the standard unit length. The overall physical length will increase by 4" for each end pocket. The coil length will remain the standard size. Coil fins are 2-1/2" high by width shown above and are mechanically bonded to copper tube at 6 fins per inch.

