

# AS4D99VS

**STANDARD MATERIALS AND CONSTRUCTION**

**FRAME:** .081" thk. (nominal) extruded aluminum, 6063-T52/T6 alloy.

**BLADE:** .081" thk. (nominal) extruded aluminum, 6063-T52/T6 alloy.  
Blades approximately 1 $\frac{5}{8}$ " on centers.

**LOUVER FACE:** Blades are contained within jambs, sill contains jambs, and head is flush with jambs.

**SCREENS:** (When indicated, in a removable frame.)

1/2" flattened aluminum (.051" thick),

-or- 1/2" sq. mesh, intermediate double-crimped aluminum wire, .063" dia.,

-or- 1 $\frac{9}{16}$ " mesh, .011" dia. aluminum wire, insect screen.

**DRAIN SILL PAN:** .060" thick (nominal) formed aluminum.

**FINISH:** Mill

**OPTIONS**

Finish - Baked Enamel, Kynar, Anodize

**NOTES**

1. 1/2" nominal deduction will be made to the opening size given.
2. Approximate shipping weight is 5.5 lbs./sq.ft.

**LOUVER SIZES**

Min Panel	Max Single Panel
12"W x 12"H	96"W x 60"H

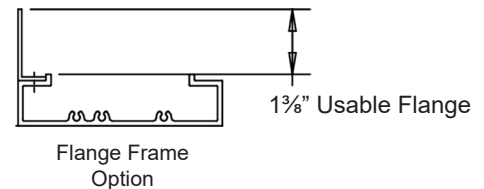
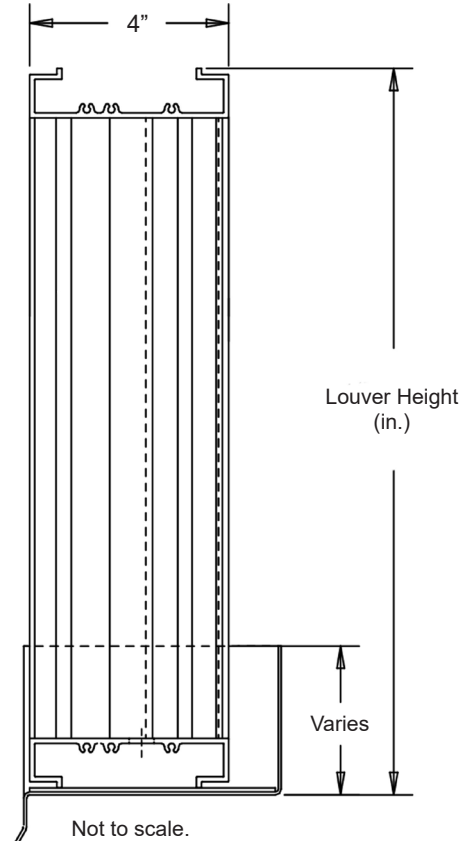
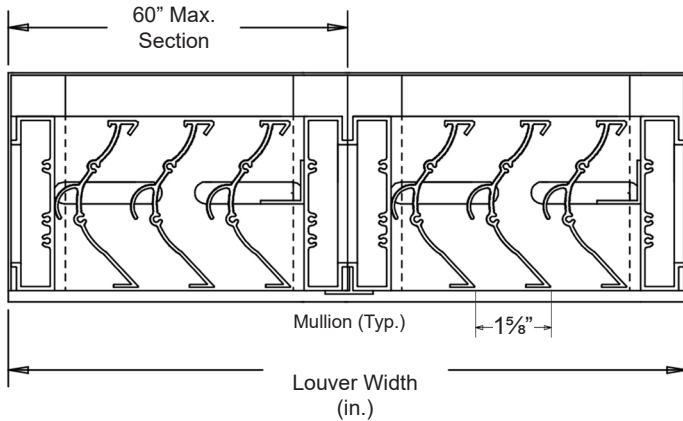

In the interest of product development, Airline Louvers reserves the right to make changes without notice.

Item #	Qty	Width	Height	Width	Height	Mullion	Type	Location	Union Made
		Opening Size		Louver Size			Screens		
<b>Arch. / Eng. :</b>						<b>EDR:</b>	<b>ECN:</b>	<b>Job:</b>	
<b>Contractor:</b>									
<b>Project:</b>						<b>Date:</b>	<b>DWN:</b>	<b>DWG:</b>	





# AS4D99VS

## PERFORMANCE DATA

Pressure Drop: .260 in. w.g. at 1000 fpm (intake)

Free Area: 7.58 sq.ft. = 47% for 48"W x 48"H sample tested in accordance with AMCA Standard 500-L.

Class "A" Rating with 100% efficiency at 3 in. rain fall at intake velocity of 1844 fpm (13,978 cfm) at wind speed of 29 mph.

Class "A" Rating with 99.1% efficiency at 8 in. rain fall at intake velocity of 1837 fpm (13,924 cfm) at wind speed of 50 mph.

Testing based on 48" x 48" based on AMCA Standard 500-L.

Ratings do not include effects of a screen.

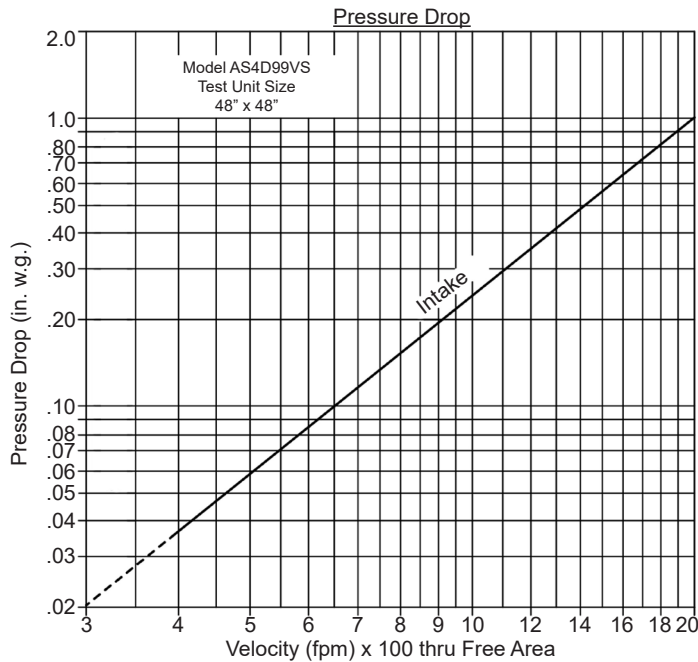

Intake air converted to standard air density.  
Tested to AMCA Standard 500-L, Figure 5.5.

		Free Area (sq. ft.)								
		Width (in.)								
Height (in.)		12"	18"	24"	30"	36"	42"	48"	54"	60"
		12"	.33	.56	.78	.99	1.25	1.48	1.69	1.94
24"	.74	1.24	1.73	2.21	2.77	3.27	3.75	4.31	4.82	
36"	1.15	1.91	2.68	3.42	4.29	5.07	5.81	6.67	7.46	
48"	1.55	2.59	3.63	4.63	5.81	6.87	7.58	9.04	10.11	
60"	1.96	3.27	4.58	5.84	7.33	8.67	9.93	11.40	12.75	
72"	2.36	3.95	5.53	7.05	8.85	10.47	11.99	13.76	15.40	
84"	2.77	4.63	6.48	8.26	10.37	12.26	14.05	16.13	18.04	
96"	3.18	5.30	7.44	9.47	11.89	14.06	16.11	18.49	20.69	

# AIRLINE<sup>TM</sup>

## L O U V E R S

# AS4D99VS

Wind Driven Rainwater Penetration Test  
Conducted to AMCA Standard 500-L.

Test size 1m x 1m (39.7" x 39.7") core area, nominal.  
Louver Free Area 5.51 square feet.

Core Ventilation (m/s)	0.0	0.5	1.0	1.5	2.0	2.5	3.0	3.5	4.0	4.5	5.0	Rain Fall / MPH
FPM	0	98	197	295	394	492	591	689	787	886	985	3 in. / hr. rain fall and 29 mph Velocity
Free Area Ventilation (cfm)	-	-	-	-	-	-	-	-	-	-	10,603	
Free Area Velocity (fpm)	-	-	-	-	-	-	-	-	-	-	1,844	
Effective Rating Class	A	A	A	A	A	A	A	A	A	A	A	
FPM	-	-	-	-	-	-	-	-	797	883	982	8 in. / hr. rain fall and 50 mph Velocity
Free Area Ventilation (cfm)	-	-	-	-	-	-	-	-	8,572	9,503	10,563	
Free Area Velocity (fpm)	-	-	-	-	-	-	-	-	1,491	1,653	1,837	
Effective Rating Class	A	A	A	A	A	A	A	A	A	A	A	

Wind Driven Rain Penetration Classifications

Class	Effectiveness %
A	100 to 99%
B	98.9% to 95%
C	94.9% to 80%
D	Below 80%

Discharge Loss Coefficient Classifications

Class	Discharge Loss Coefficient
1	0.4 and above
2	0.3 to 0.399
3	0.2 to 0.299
4	0.199 and below

$$\frac{\text{Discharge Coefficient}}{\text{Intake Cd} = 0.25 \text{ (Class 3)}}$$

Class 1 Loss Coefficient has the least resistance to airflow.

1. Core area is the front opening of a louver assembly with the blades removed.
2. Core area velocity is the airflow rate through the louver divided by the core area (39.37" x 39.37").
3. Free area is the minimum area through which air can pass. It is determined by multiplying the sum of the minimum distance between intermediate blades, top blade and head, bottom blade and sill, by the minimum distance between jambs.
4. Discharge loss coefficient is calculated by dividing a louver actual airflow rate vs. a theoretical airflow for the opening, providing an indication of the louver air flow characteristics.



Airline Louvers certifies that the Model AS4D99VS shown herein is licensed to bear the AMCA seal. The ratings shown are based on tests and procedures performed in accordance with AMCA Publication 511 and comply with the requirements of the AMCA Certified Ratings Program. The AMCA Certified Ratings Seal applies to Air Performance and Wind Driven Rain Ratings only.