

STANDARD MATERIALS AND CONSTRUCTION

- FRAME:** 16 GA. galvanized steel, 4" deep hat-shaped frame.
- BLADE:** 16 GA. galvanized steel, airfoil design, 8" wide max.
- SHAFT:** 1/2" dia. plated steel shaft, full length.
- BEARINGS:** Stainless steel flanged sleeve, press fit into frame.
- OPERATOR:** 1/8" thick (nominal) formed steel bracket, face mounted, located in the airstream.
- FINISH:** Mill.
- MAX TEMP:** 250°F.
Consult the factory for temperature limits over 250°F.

OPTIONS

- Materials - Full stainless steel construction, extruded aluminum, galvanized steel, etc.
- Actuators - Electric or Pneumatic
- Jamb Seals - Flexible stainless steel or Neoprene
- Blade Edge Seals - Flexible stainless steel or Neoprene
- Finishes - Acrylic, baked enamel, etc.
- Jamb Linkage
- Flange for Channel Frames - Standard 2", Up to 3 1/2"
- Frame holes for Channel Frames
- Other types of bearings

NOTES

1. 1/4" nominal deduction will be made to the opening size given. Dampers with channel frames will be fabricated to exact I.D. dimensions, unless otherwise specified.
2. Round dampers are available in 1" increments only.
3. Construction may be with other materials when required to meet special conditions, such as: temperature, pressure, velocity, system environment, or other specifications.
4. Approximate shipping weight is 12 lbs./sq.ft. for Hat-shaped Frame and 16 lbs./sq.ft. for Channel Frame.

DAMPER SIZES

Frame	Min. Size	Max. Size
Hat Shape	12"W x 8"H (Single Blade)	48"W x 72"H
Channel	12"W x 12" (Opposed)	48"W x 96"H

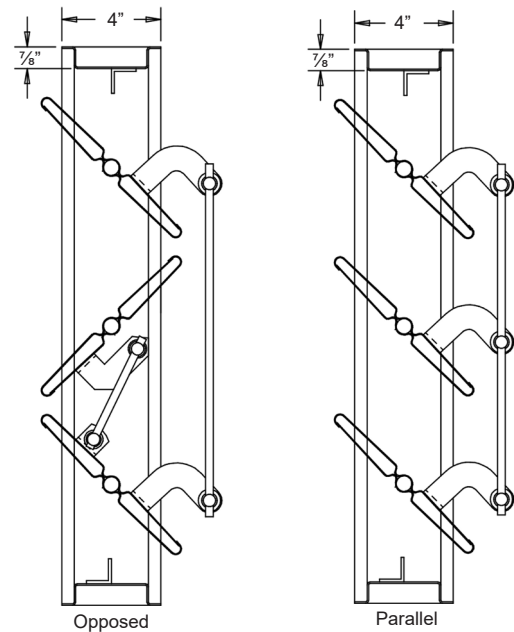
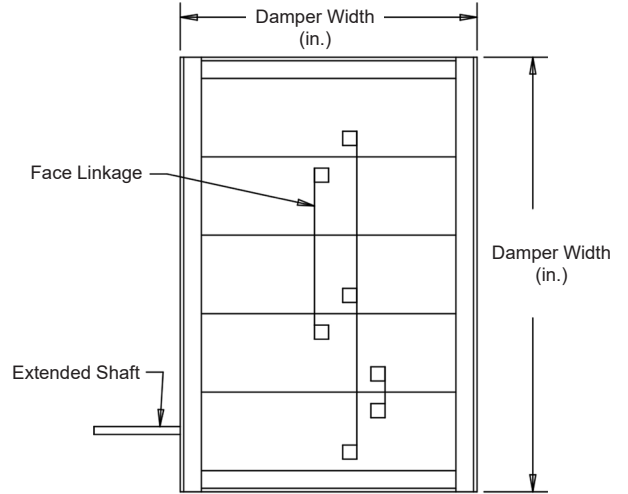
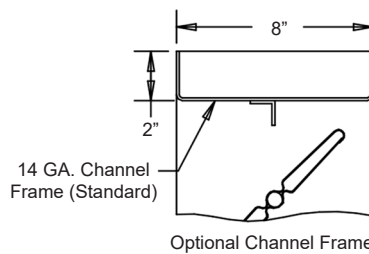

Item #	Qty	Width	Height	Parallel Blades	Opposed Blades	Seals	Actuator Model	Interior	Exterior	N.C.	N.O.	Union Made
								Act. Location		Function		
Arch. / Eng.:						EDR:		ECN:		Job:		
Contractor:												
Project:						Date:		DWN:		DWG:		



PERFORMANCE DATA

Pressure Drop vs. Duct Velocity

Pressure drop ratings are based on AMCA Standard 500, using test set-up figure 5.3 for a damper installed with duct upstream and downstream. Static pressures are corrected to .075 lb./cu.ft. air density.

(Sample Damper - 42"W x 42"H I.D.)

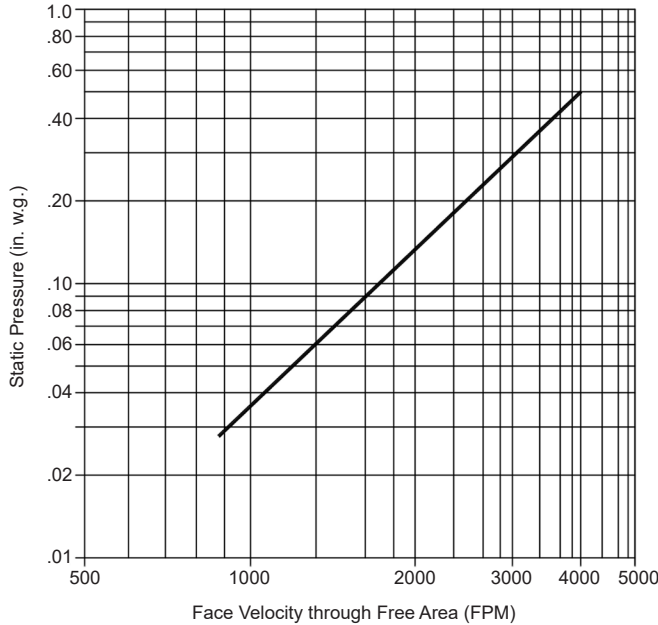

Damper Design Limitations

To ensure proper damper operation and air leakage performance for this damper design, the graph shown provides information on static pressure and blade length limits, and provides a relationship between damper cost and the application.

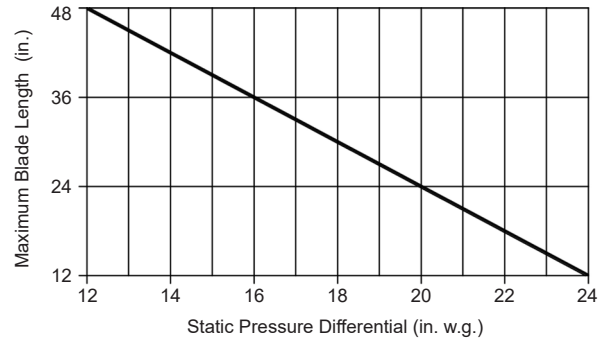

This damper's design at a blade length of 48" has a maximum allowable blade deflection of $L / 360$ for the static pressure indicated on the chart. At reduced blade lengths, higher static pressure limits can be attained without sacrificing damper operating and performance characteristics.

Air Leakage (Total CFM)

		Damper Width (in. I.D.)						
		12"	18"	24"	30"	36"	42"	48"
Damper Height (in. I.D.)	12"	4	6	8	10	12	14	16
	24"	8	12	16	20	24	28	32
	36"	12	18	24	30	36	42	48
	48"	16	24	32	40	48	56	64
	60"	20	30	40	50	60	70	80
	72"	24	36	48	60	72	84	96
	84"	28	42	56	70	84	98	112
	96"	32	48	64	80	96	112	128

Regarding the shaded area; Damper height can increase to 96" when furnished with a Channel Frame.

Air leakage quantities shown in the chart are results of tests per AMCA Standard 500 and are shown at 1 in. w.g. differential pressure and are corrected to .075 lb./cu.ft. air density.

For determining leakage values greater than 1 in. w.g., use the multiplier correction chart below.

Static Pressure (in.)	2	3	4	5	6	7	8	9	10	11	12
Multiplier Correction Factor	1.5	2.0	2.5	2.8	3.1	3.4	3.8	4.4	5.0	5.6	6.3

Air leakage ratings are based on AMCA Standard 500, using test set-up Fig. 5.4 with a damper closing torque applied to the damper of 15 in. lbs./sq.ft. of damper face area for a 48" x 72", with a minimum of 25 in. lbs./sq.ft. of a damper area for a size 48" x 9½".

Damper air leakage shown is based on dampers furnished with blade and jamb seals.