

**STANDARD MATERIALS AND CONSTRUCTION**

**FRAME:** .125" to .250" thick (nominal) extruded aluminum 6063-T52/T6 alloy.  
Grille depth can be 2" to 6" deep.

**BLADE:** .125" to .250" thick (nominal) extruded aluminum 6063-T52/T6 alloy.  
Blades can have 2" to 12" vertical and horizontal spacing and horizontal blade angle from 0° to 45°.

**CONSTRUCTION:** All welded construction.

**FINISH:** Factory mill.

**OPTIONS**

Finishes - Kynar, Baked Enamel, Clear and Color Anodize

**GRILLE SCREEN SIZES**

Min Panel	Max Single Panel
12"W x 12"H	60"W x 96"H (40 sq.ft.)

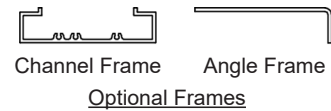
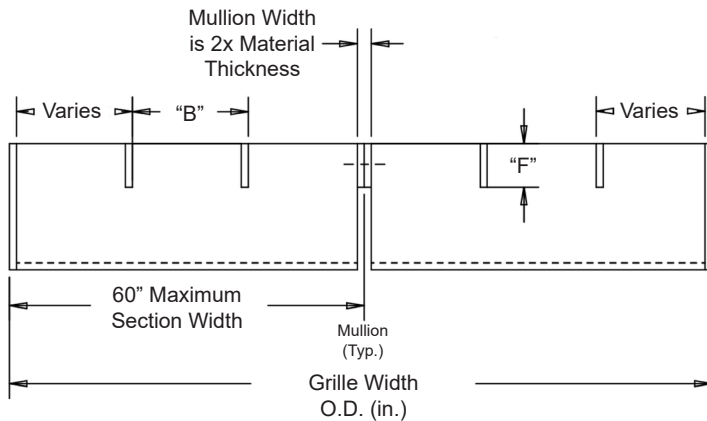
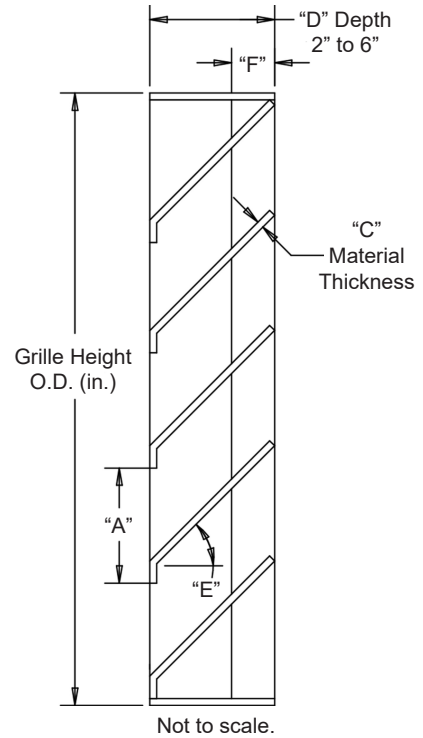

- "A" = 2" to 12" (Horizontal Blade Spacing)
- "B" = 2" to 12" (Vertical Blade Spacing)
- "C" = .125" to .250" (Material Thickness)
- "D" = 2" to 6" (Grille Depth)
- "E" = 0° to 45° (Blade Angle)
- "F" = 1" minimum (Vertical Blade Depth)

Item #	Qty	Horizontal	Vertical	Grille Depth	Material Thickness	Blade Angle	Union Made
		Blade Spacing					
Arch. / Eng. :				EDR:	ECN:	Job:	
Contractor:				Date:	DWN:	DWG:	
Project:							

