

Extruded Aluminum Louver ▲ 6" Deep ▲ 35° Drainable Blades ▲ Airfoil Adjustable Blades ▲ Concealed Mullion

STANDARD MATERIALS AND CONSTRUCTION

FRAME: .081" thk. (nominal) extruded aluminum, 6063-T52/T6 alloy. Channel type frame.

BLADES: Stationary blades made from .081" thk. (nominal) extruded aluminum 6063-T52/T6 alloy. Adjustable Airfoil blades made from .125" thk. (nominal) extruded aluminum 6063-T52/T6 alloy. Blades are approximately 4½" on centers.

LOUVER FACE: Full width sill with head and blades contained within jambs. Concealed mullion with continuous length stationary blade.

LINKAGE: Extruded aluminum, concealed in the channel out of the airstream. The pivots, which rotate in Celcon bearings, are .50" dia. Zinc plated machined steel. The pivot is locked to the ⅝" dia. aluminum linkage rod by a ¼ - 20 set screw with an epoxy locking patch.

BEARINGS: Celcon bearing material, so there will be no metal to metal friction.

SHAFTS: .50" dia. aluminum "Pin-Lock" rod.

SEALS: Extruded silicone rubber seals at blade edge. Foam on bottom blade and polycarbonate jamb seals. Stainless steel at jamb required on painted louvers.

SCREEN: (When indicated, in a removable frame)
½" flattened aluminum, .051" thk.,

-or- Insect screen 1⅞ aluminum mesh, .011" dia.,

-or- ½" sq. mesh intermediate double crimped aluminum wire, .063" dia.

FINISH: Mill.

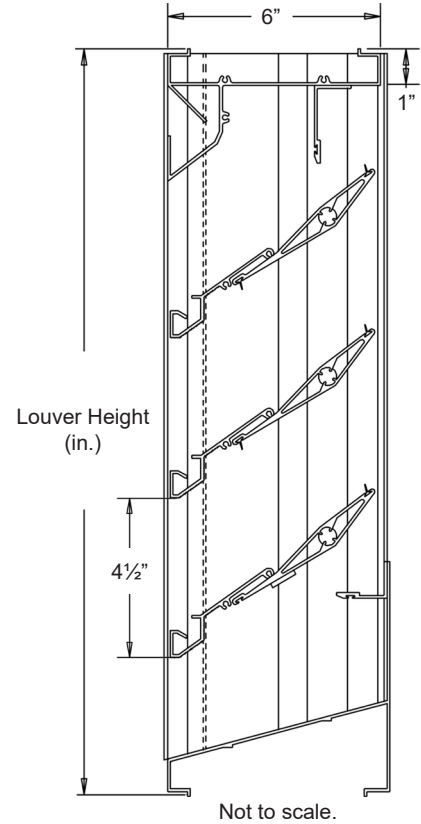

OPTIONS

Finishes - Enamels, Epoxies, etc.

Other screens also available.

Actuators - Electric, Pneumatic, Manual, etc.

NOTES

1. ½" nominal deduction will be made to the opening size given.
2. Approximate shipping weight is 5.7 lbs./sq.ft.

LOUVER SIZES

Min Panel	Max Single Panel
12"W x 19"H	96"W x 72"H

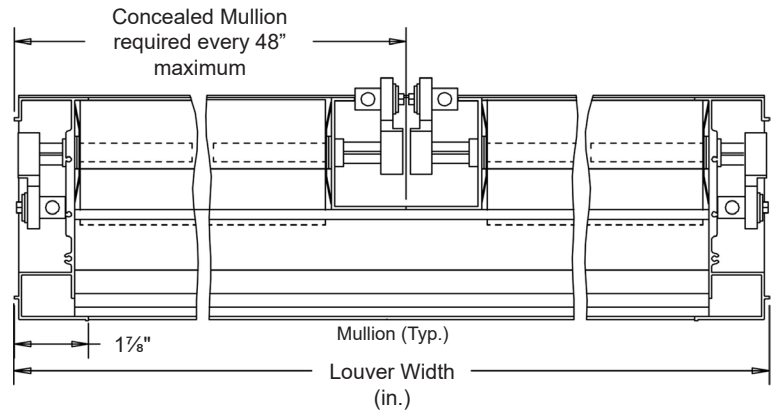
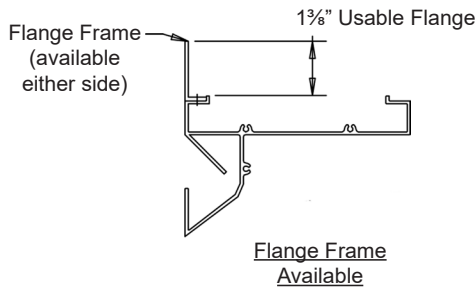

* Visible Mullion required every 96" maximum

Item #	Qty	Width	Height	Width	Height	Mullion	Type	Location		
		Opening Size		Louver Size			Screens			Union Made
Arch. / Eng. :						EDR:		ECN:		Job:
Contractor:										
Project:						Date:		DWN:		DWG: