

STANDARD MATERIALS AND CONSTRUCTION

FRAME: .081" thick (nominal) extruded aluminum, 6063-T52/T6 alloy.

BLADE: .081" thick (nominal) extruded aluminum, 6063-T52/T6 alloy.
Blades approximately 3" on center.

LOUVER FACE: Full width sill, with blades and head contained in jambs.

SCREEN: (When indicated.)

½" flattened aluminum (.051" thick),

-or- ½" sq. mesh, intermediate double-crimped aluminum wire, .063" dia.,

-or- 19/16 mesh, .011" dia. aluminum wire, insect screen.

FINISH: Mill

OPTIONS

Finish - Baked Enamel, Kynar, Anodize

NOTES

- Nominal deductions will be made to the opening size given.
- Approximate shipping weight is 5.2 lbs./sq.ft.

LOUVER SIZES

Min Panel	Max Single Panel
12"W x 12"H	60"W x 96"H

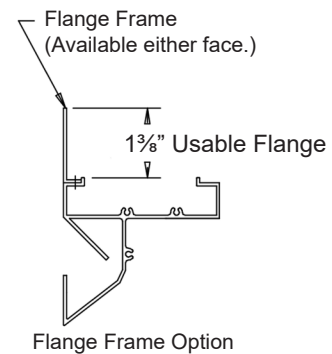
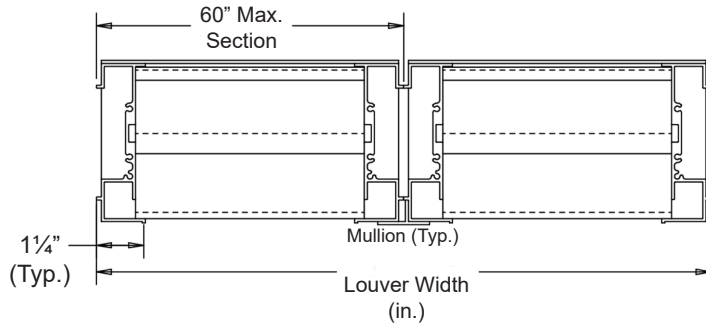
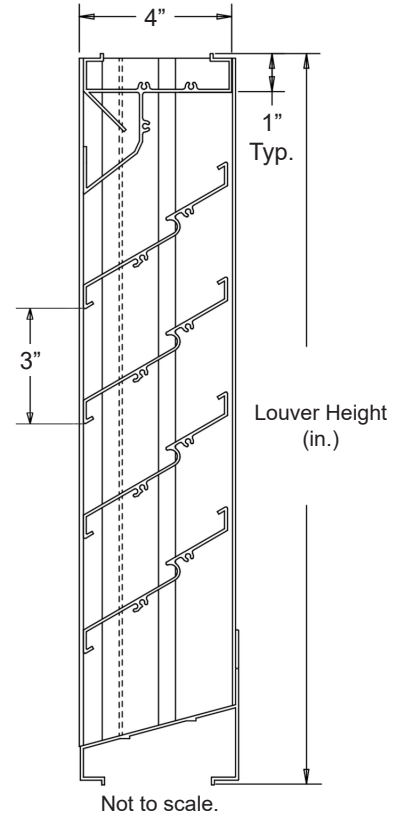

Item #	Qty	Width	Height	Width	Height	Mullion	Type	Location	Union Made
		Opening Size		Louver Size			Screens		
Arch. / Eng. :						EDR:	ECN:	Job:	
Contractor:									
Project:						Date:	DWN:	DWG:	



PERFORMANCE DATA

Pressure Drop: .08 in. w.g. at 780 fpm (Intake)
 Free Area: 7.66 sq.ft. = 47.9% for 48"W x 48"H sample tested in accordance with AMCA Standard 500-L.
 Beginning Point of Water Penetration: 763 fpm

Ratings do not include effects of a screen.

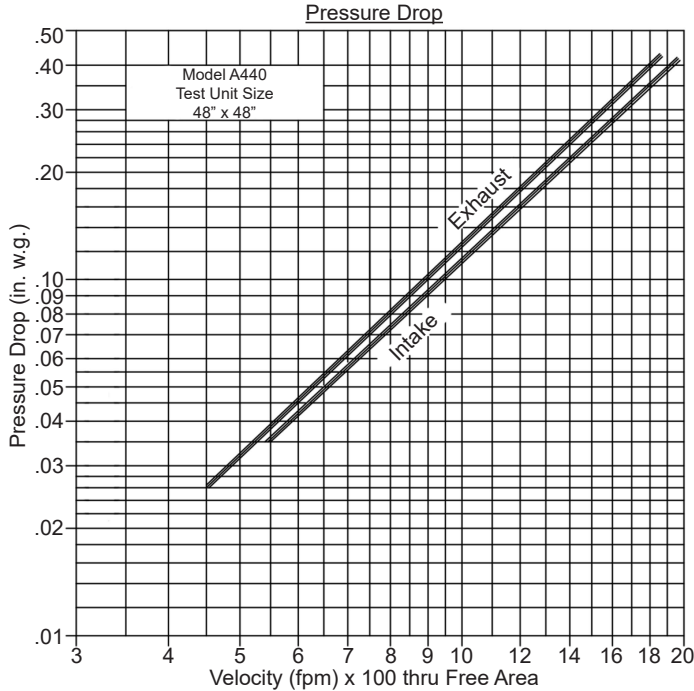

Intake air converted to standard air density.
 Tested to AMCA Standard 500-L, Figure 5.5.

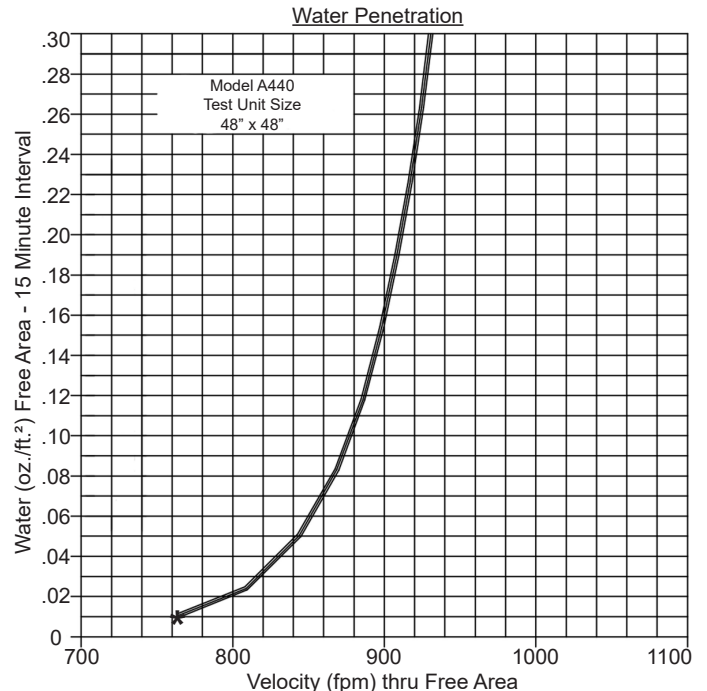

763 (FPM) Beginning Point of Water Penetration

Free Area (sq.ft.)

		Width (in.)								
		12"	18"	24"	30"	36"	42"	48"	54"	60"
Height (in.)	12"	.32	.51	.71	.91	1.10	1.30	1.50	1.70	1.89
	24"	.74	1.21	1.68	2.15	2.62	3.08	3.55	4.02	4.49
	36"	1.17	1.91	2.65	3.39	4.13	4.87	5.61	6.35	7.08
	48"	1.60	2.61	3.62	4.63	5.64	6.65	7.66	8.67	9.68
	60"	2.03	3.31	4.59	5.87	7.15	8.43	9.71	10.99	12.28
	72"	2.46	4.01	5.56	7.11	8.66	10.22	11.77	13.32	14.87
	84"	2.89	4.71	6.53	8.35	10.18	12.00	13.82	15.64	17.47
	96"	3.32	5.41	7.50	9.60	11.69	13.78	15.88	17.97	20.06